

Band Switching Diodes

Features

- Silicon Planar Diode
- Saving space
- Hermetic sealed parts
- Fits onto SOD 323 footprints
- Electrical data identical with the devices BA682.BA683 / BA982.BA983
- Low differential forward resistance
- Low diode capacitance
- High reverse impedance

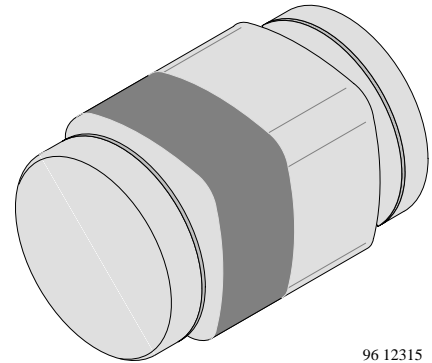

96 12315

Applications

Band switching in VHF-tuners

Order Instruction

Type	Type Differentiation	Ordering Code	Remarks
BA1282	$V_R = 35 \text{ V}$, $r_f @ I_F 3\text{mA} = \max 0.7 \Omega$	BA1282-TR	Tape and Reel
BA1283	$V_R = 35 \text{ V}$, $r_f @ I_F 3\text{mA} = \max 1.2 \Omega$	BA1283-TR	Tape and Reel

Absolute Maximum Ratings

$T_j = 25^\circ\text{C}$

Parameter	Test Conditions	Type	Symbol	Value	Unit
Reverse voltage			V_R	35	V
Forward current			I_F	100	mA
Junction temperature			T_j	150	$^\circ\text{C}$
Storage temperature range			T_{stg}	-55...+150	$^\circ\text{C}$

Maximum Thermal Resistance

$T_j = 25^\circ\text{C}$

Parameter	Test Conditions	Symbol	Value	Unit
Junction ambient	mounted on epoxy-glass hard tissue, Fig. 1, 35 μm copper clad, 0.9 mm ² copper area per electrode	R_{thJA}	500	K/W

Electrical Characteristics

$T_j = 25^\circ\text{C}$

Parameter	Test Conditions	Type	Symbol	Min	Typ	Max	Unit
Forward voltage	$I_F=100\text{mA}$		V_F			1	V
Reverse current	$V_R=20\text{ V}$		I_R			50	nA
Diode capacitance	$f=100\text{MHz}, V_R=1\text{ V}$		C_D			1.5	pF
	$f=100\text{MHz}, V_R=3\text{ V}$	BA1282	C_D			1.25	pF
	$f=100\text{MHz}, V_R=3\text{ V}$	BA1283	C_D			1.2	pF
Differential forward resistance	$f=200\text{MHz}, I_F=3\text{mA}$	BA1282	r_f			0.7	Ω
	$f=200\text{MHz}, I_F=3\text{mA}$	BA1283	r_f			1.2	Ω
	$f=200\text{MHz}, I_F=10\text{mA}$	BA1282	r_f			0.5	Ω
	$f=200\text{MHz}, I_F=10\text{mA}$	BA1283	r_f			0.9	Ω

Characteristics ($T_j = 25^\circ\text{C}$ unless otherwise specified)

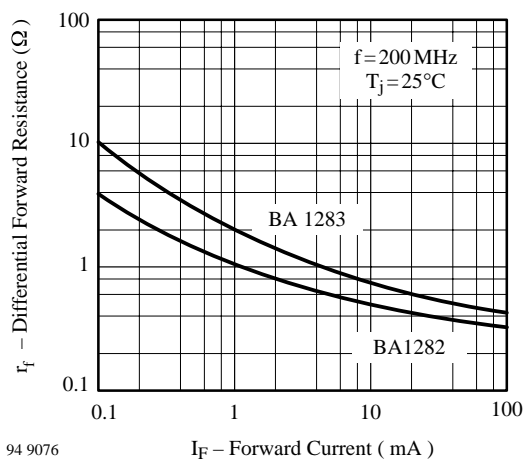

Figure 1. Differential Forward Resistance vs. Forward Current

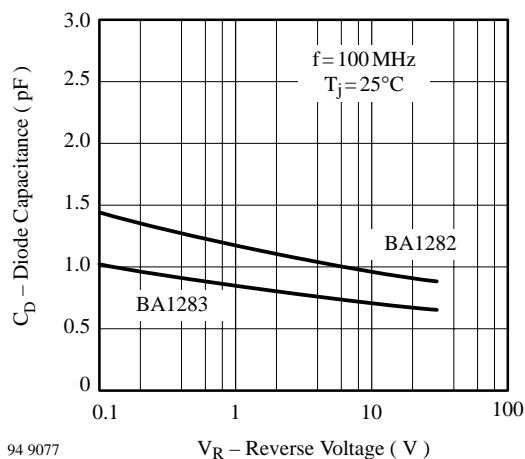

Figure 2. Diode Capacitance vs. Reverse Voltage

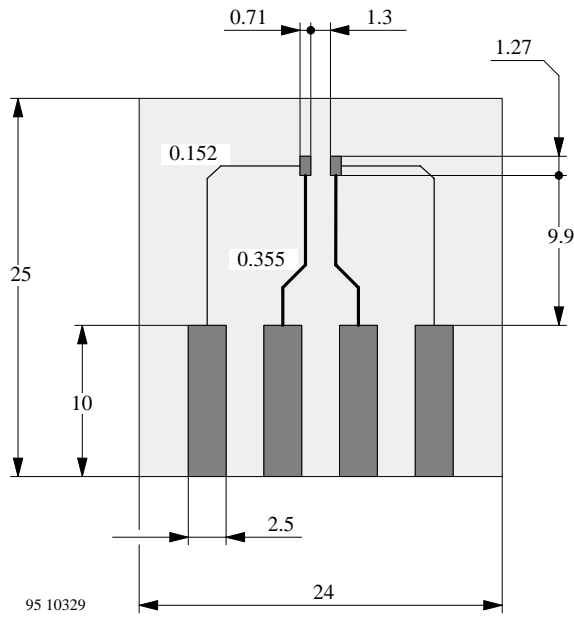

Figure 3. Board for R_{thJA} definition (in mm)

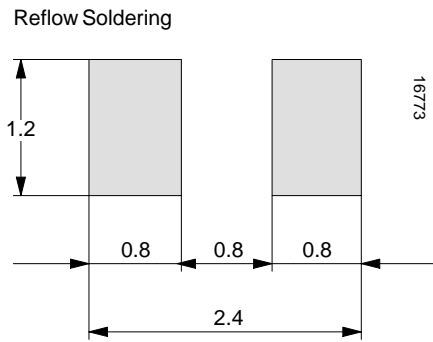

Figure 4.

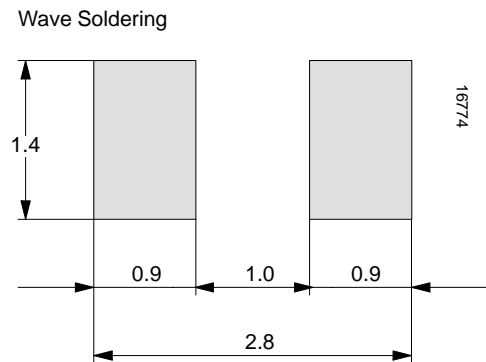
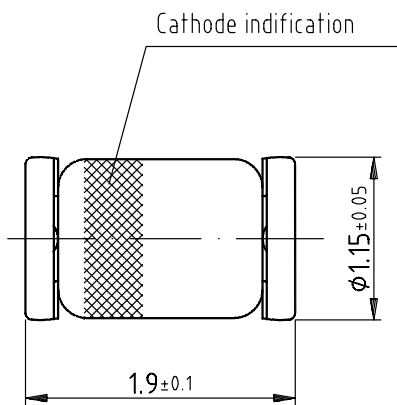
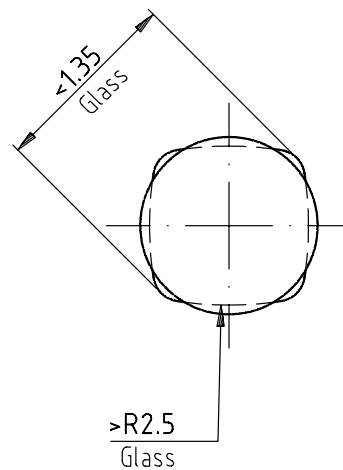

Figure 5.

Dimensions in mm



Glass case
Micro MELF



Drawing-No.: 6.560-5007.01-4
Issue: 5; 06.06.01

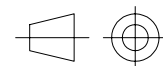

technical drawings
according to DIN
specifications

96 12072

Ozone Depleting Substances Policy Statement

It is the policy of **Vishay Semiconductor GmbH** to

1. Meet all present and future national and international statutory requirements.
2. Regularly and continuously improve the performance of our products, processes, distribution and operating systems with respect to their impact on the health and safety of our employees and the public, as well as their impact on the environment.

It is particular concern to control or eliminate releases of those substances into the atmosphere which are known as ozone depleting substances (ODSs).

The Montreal Protocol (1987) and its London Amendments (1990) intend to severely restrict the use of ODSs and forbid their use within the next ten years. Various national and international initiatives are pressing for an earlier ban on these substances.

Vishay Semiconductor GmbH has been able to use its policy of continuous improvements to eliminate the use of ODSs listed in the following documents.

1. Annex A, B and list of transitional substances of the Montreal Protocol and the London Amendments respectively
2. Class I and II ozone depleting substances in the Clean Air Act Amendments of 1990 by the Environmental Protection Agency (EPA) in the USA
3. Council Decision 88/540/EEC and 91/690/EEC Annex A, B and C (transitional substances) respectively.

Vishay Semiconductor GmbH can certify that our semiconductors are not manufactured with ozone depleting substances and do not contain such substances.

We reserve the right to make changes to improve technical design and may do so without further notice.

Parameters can vary in different applications. All operating parameters must be validated for each customer application by the customer. Should the buyer use Vishay-Semiconductors products for any unintended or unauthorized application, the buyer shall indemnify Vishay-Semiconductors against all claims, costs, damages, and expenses, arising out of, directly or indirectly, any claim of personal damage, injury or death associated with such unintended or unauthorized use.

Vishay Semiconductor GmbH, P.O.B. 3535, D-74025 Heilbronn, Germany
Telephone: 49 (0)7131 67 2831, Fax number: 49 (0)7131 67 2423