

Glass Passivated Junction Fast Switching Rectifier

Reverse Voltage 400 to 1000 V
 Forward Current 1.0 A

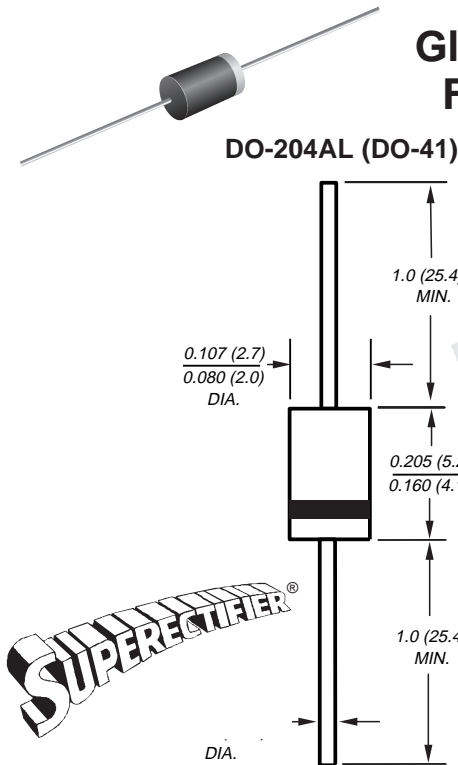

NOTE: Lead diameter is $\frac{0.026 (0.66)}{0.023 (0.58)}$ for suffix "E" part numbers

Dimensions in inches and (millimeters)

*Glass-plastic encapsulation technique is covered by

Patent No. 3,996,602, and brazed-lead assembly by Patent No. 3,930,306

Features

- Plastic package has Underwriters Laboratories Flammability Classification 94V-0
- High temperature metallurgically bonded construction
- For use in high frequency rectifier circuits
- Fast switching for high efficiency
- Cavity-free glass passivated junction
- Capable of meeting environmental standards of MIL-S-19500
- 1.0 Ampere operation at $T_A=55^\circ\text{C}$ with no thermal runaway
- Typical I_R less than $0.1\mu\text{A}$
- High temperature soldering guaranteed: $350^\circ\text{C}/10$ seconds, 0.375" (9.5mm) lead length, 5 lbs. (2.3kg) tension

Mechanical Data

Case: JEDEC DO-204AL, molded plastic over glass body

Terminals: Plated axial leads, solderable per MIL-STD-750, Method 2026

Polarity: Color band denotes cathode end

Mounting Position: Any

Weight: 0.012 ounce, 0.3 gram

Maximum Ratings & Thermal Characteristics Ratings at 25°C ambient temperature unless otherwise specified.

Parameter	Symbols	BA157GP	BA158GP	BA159DGP	BA159GP	Units
Maximum repetitive peak reverse voltage	V_{RRM}	400	600	800	1000	V
Maximum RMS voltage	V_{RMS}	280	420	560	700	V
Maximum DC blocking voltage	V_{DC}	400	600	800	1000	V
Maximum average forward rectified current 0.375" (9.5mm) lead length at $T_A=55^\circ\text{C}$	$I_{F(AV)}$	1.0				A
Peak forward surge current 10ms single half sine-wave superimposed on rated load at $T_A=25^\circ\text{C}$	I_{FSM}	20				A
Typical thermal resistance (NOTE 1)	$R_{\theta JA}$	55				$^\circ\text{C}/\text{W}$
Operating junction and storage temperature range	T_J, T_{STG}	- 65 to +175				$^\circ\text{C}$

Electrical Characteristics Ratings at 25°C ambient temperature unless otherwise specified.

Parameter	Symbols	BA157GP	BA158GP	BA159DGP	BA159GP	Units
Maximum instantaneous forward voltage at 1.0A	V_F	1.3				V
Maximum DC reverse current at rated DC blocking voltage $T_A=25^\circ\text{C}$	I_R	5.0				μA
Maximum reverse recovery time at $I_F=0.5\text{A}, I_R=1.0\text{A}, I_{rr}=0.25\text{A}$	t_{rr}	150	250	500	500	ns
Typical junction capacitance at 4.0V, 1MHz	C_J	15				pF

Notes:

(1) Thermal resistance from junction to ambient at 0.375" (9.5mm) lead length, P.C.B. mounted

BA157GP thru BA159GP



Vishay Semiconductors
formerly General Semiconductor

Ratings and Characteristic Curves ($T_A = 25^\circ\text{C}$ unless otherwise noted)

Fig. 1 – Forward Current Derating Curve

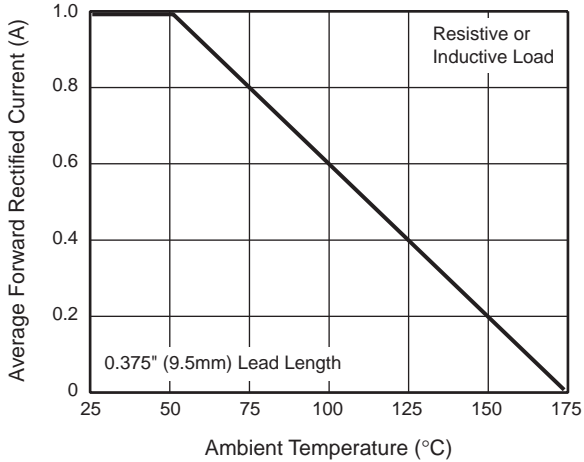

Fig. 2 – Maximum Non-Repetitive Peak Forward Surge Current

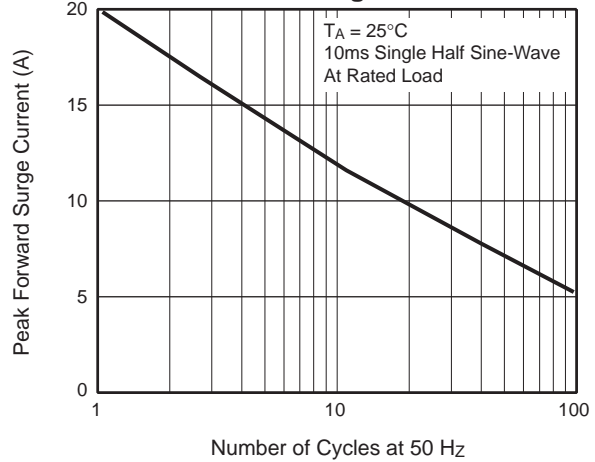

Fig. 3 – Typical Instantaneous Forward Characteristics

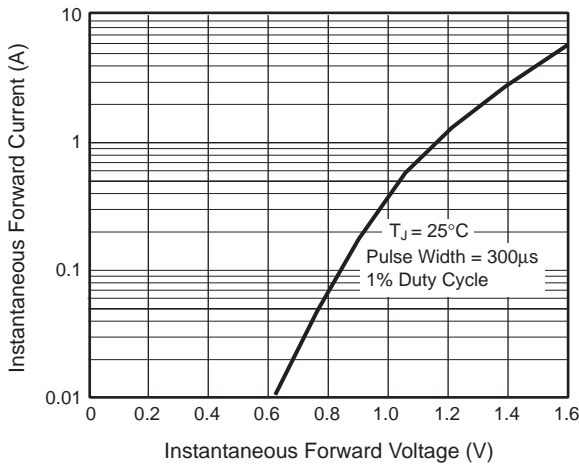

Fig. 4 – Typical Reverse Characteristics

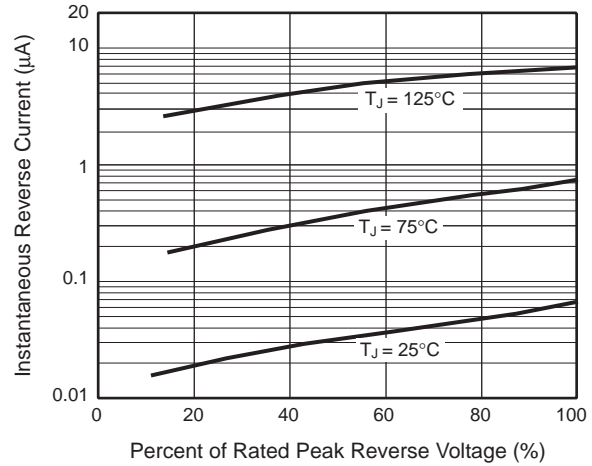

Fig. 5 – Typical Junction Capacitance

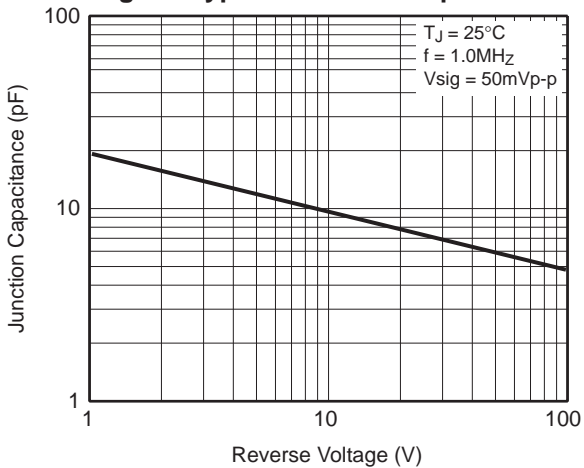

Fig. 6 – Typical Transient Thermal Impedance

