

## Dual Switching Diode

### Features

- Fast switching speed
- High conductance
- Surface mount package ideally suited for automatic insertion
- Connected in series

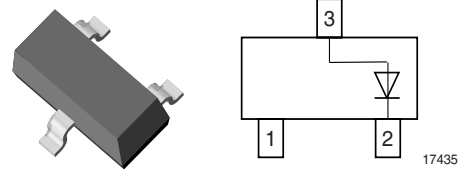

**Marking:** KJE, JE

**Packaging Codes/Options:**

E8/10 K per 13" reel (8 mm tape), 30 K/box

E9/3K per 7" reel (8 mm tape), 30 K/box

### Mechanical Data

**Case:** SOT-23 Plastic Package

**Weight:** approx. 8 mg

### Parts Table

Part	Type differentiation	Ordering code	Marking	Remarks	Package
BAV99	Dual Serial	BAV99-GS08	JE	Tape and Reel	SOT-23

### Absolute Maximum Ratings

$T_{amb} = 25\text{ }^{\circ}\text{C}$ , unless otherwise specified

Parameter	Test condition	Symbol	Value	Unit
Non repetitive peak reverse voltage		$V_{RM}$	100	V
Repetitive peak reverse voltage = Working peak reverse voltage = DC Blocking voltage		$V_{RRM} = V_{RWM} = V_R$	70	V
Peak forward surge current	$t_p = 1\text{ s}$	$I_{FSM}$	1	A
	$t_p = 1\text{ }\mu\text{s}$	$I_{FSM}$	4.5	A
Average forward current	half wave rectification with resistive load and $f \geq 50\text{ MHz}$ , on ceramic substrate 10 mm x 8 mm x 0.7 mm	$I_{FAV}$	150	mA
Forward current	on ceramic substrate 10 mm x 8 mm x 0.7 mm	$I_F$	250	mA
Power dissipation	on ceramic substrate 10 mm x 8 mm x 0.7 mm	$P_{tot}$	300	mW

### Maximum Thermal Resistance

$T_{amb} = 25\text{ }^{\circ}\text{C}$ , unless otherwise specified

Parameter	Test condition	Symbol	Value	Unit
Junction ambient	on ceramic substrate 10 mm x 8 mm x 0.7 mm	$R_{thJA}$	430	K/W
Junction and storage temperature range		$T_j = T_{stg}$	- 55 to + 150	$^{\circ}\text{C}$

## Electrical Characteristics

$T_{amb} = 25\text{ }^{\circ}\text{C}$ , unless otherwise specified

Parameter	Test condition	Symbol	Max	Unit
Forward voltage	$I_F = 1\text{ mA}$	$V_F$	715	mV
	$I_F = 10\text{ mA}$	$V_F$	855	mV
	$I_F = 50\text{ mA}$	$V_F$	1	V
	$I_F = 150\text{ mA}$	$V_F$	1.25	V
Reverse current	$V_R = 70\text{ V}$	$I_R$	2.5	$\mu\text{A}$
	$V_R = 70\text{ V}, T_j = 150\text{ }^{\circ}\text{C}$	$I_R$	50	$\mu\text{A}$
	$V_R = 25\text{ V}, T_j = 150\text{ }^{\circ}\text{C}$	$I_R$	30	$\mu\text{A}$
Diode capacitance	$V_R = 0, f = 1\text{ MHz}$	$C_D$	1.5	pF
Reverse recovery time	$I_F = 10\text{ mA}$ to $I_R = 1\text{ mA}$ , $V_R = 6\text{ V}$ , $R_L = 100\ \Omega$	$t_{rr}$	6	ns

## Typical Characteristics ( $T_{amb} = 25\text{ }^{\circ}\text{C}$ unless otherwise specified)

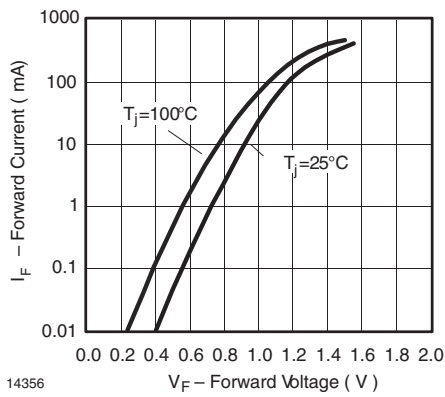
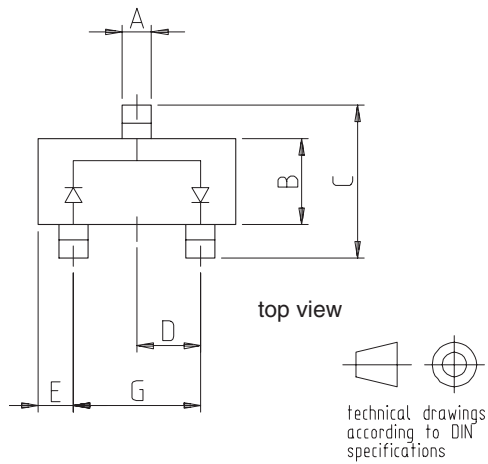
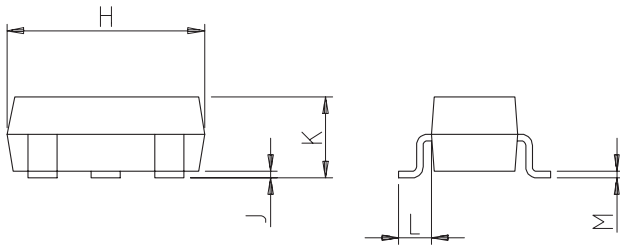

Figure 1. Forward Current vs. Forward Voltage

## Package Dimensions in mm



SOT-23		
Dim	Min	Max
A	0.37	0.50
B	1.19	1.40
C	2.10	2.50
D	0.89	1.05
E	0.45	0.61
G	1.78	2.05
H	2.79	3.05
J	0.013	0.15
K	0.89	1.10
L	0.45	0.61
M	0.076	0.130
All Dimensions in mm		

14373

### Ozone Depleting Substances Policy Statement

It is the policy of **Vishay Semiconductor GmbH** to

1. Meet all present and future national and international statutory requirements.
2. Regularly and continuously improve the performance of our products, processes, distribution and operating systems with respect to their impact on the health and safety of our employees and the public, as well as their impact on the environment.

It is particular concern to control or eliminate releases of those substances into the atmosphere which are known as ozone depleting substances (ODSs).

The Montreal Protocol (1987) and its London Amendments (1990) intend to severely restrict the use of ODSs and forbid their use within the next ten years. Various national and international initiatives are pressing for an earlier ban on these substances.

**Vishay Semiconductor GmbH** has been able to use its policy of continuous improvements to eliminate the use of ODSs listed in the following documents.

1. Annex A, B and list of transitional substances of the Montreal Protocol and the London Amendments respectively
2. Class I and II ozone depleting substances in the Clean Air Act Amendments of 1990 by the Environmental Protection Agency (EPA) in the USA
3. Council Decision 88/540/EEC and 91/690/EEC Annex A, B and C (transitional substances) respectively.

**Vishay Semiconductor GmbH** can certify that our semiconductors are not manufactured with ozone depleting substances and do not contain such substances.

**We reserve the right to make changes to improve technical design  
and may do so without further notice.**

Parameters can vary in different applications. All operating parameters must be validated for each customer application by the customer. Should the buyer use Vishay Semiconductors products for any unintended or unauthorized application, the buyer shall indemnify Vishay Semiconductors against all claims, costs, damages, and expenses, arising out of, directly or indirectly, any claim of personal damage, injury or death associated with such unintended or unauthorized use.

Vishay Semiconductor GmbH, P.O.B. 3535, D-74025 Heilbronn, Germany  
Telephone: 49 (0)7131 67 2831, Fax number: 49 (0)7131 67 2423