

Dual Varicap Diode

Features

- Silicon Epitaxial Planar Diode
- Common cathode

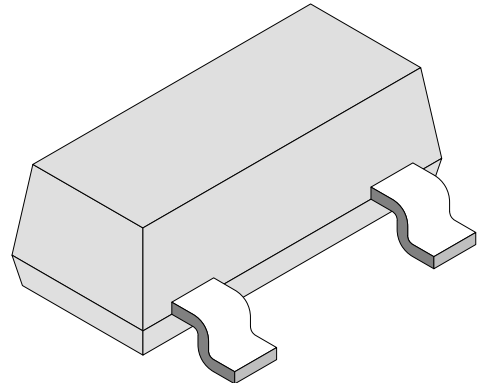

Applications

Tuning of separate resonant circuits, push-pull circuits in FM range, especially for car radios

94 8550

Order Instruction

Type	Type Differentiation	Ordering Code	Remarks
BB804	$V_{RRM} = 20 \text{ V}$, C_D 42–47, 5pF	BB804-GS08	Tape and Reel
BB804-0	$V_{RRM} = 20 \text{ V}$, C_D 42–43, 5pF	BB804-0-GS08	Tape and Reel
BB804-1	$V_{RRM} = 20 \text{ V}$, C_D 43–44, 5pF	BB804-1-GS08	Tape and Reel
BB804-2	$V_{RRM} = 20 \text{ V}$, C_D 44–45, 5pF	BB804-2-GS08	Tape and Reel
BB804-3	$V_{RRM} = 20 \text{ V}$, C_D 45–46, 5pF	BB804-3-GS08	Tape and Reel
BB804-4	$V_{RRM} = 20 \text{ V}$, C_D 46–47, 5pF	BB804-4-GS08	Tape and Reel

Absolute Maximum Ratings

$T_j = 25^\circ\text{C}$

Parameter	Test Conditions	Type	Symbol	Value	Unit
Repetitive peak reverse voltage			V_{RRM}	20	V
Reverse voltage			V_R	18	V
Forward current			I_F	50	mA
Junction temperature			T_j	100	$^\circ\text{C}$
Storage temperature range			T_{stg}	-55...+150	$^\circ\text{C}$

Electrical Characteristics

$T_j = 25^\circ\text{C}$

Parameter	Test Conditions	Type	Symbol	Min	Typ	Max	Unit
Reverse current	$V_R=16\text{ V}$		I_R			20	nA
	$V_R=16\text{ V}, T_j=60^\circ\text{C}$		I_R			0.2	μA
Diode capacitance ¹⁾	$V_R=2\text{ V}, f=1\text{MHz}$		C_D	42		47.5	pF
Diode capacitance	$V_R=2\text{ V}, f=1\text{MHz}$	Group 0	C_D	42		43.5	pF
		Group 1	C_D	43		44.5	pF
		Group 2	C_D	44		45.5	pF
		Group 3	C_D	45		46.5	pF
		Group 4	C_D	46		47.5	pF
Capacitance ratio	$V_R=2\text{ V}, 8\text{ V}, f=100\text{MHz}$		C_{D2}/C_{D8}	1.65		1.75	
Series resistance	$C_D=38\text{pF}, f=100\text{MHz}$		r_s		0.3	0.4	Ω
Figure of merit	$C_D=38\text{pF}, f=100\text{MHz}$		Q	100	140		

¹⁾ A packing unit (reel) contains diodes from one capacitance group only.
Delivery of single capacitance groups available only on request.

Dimensions in mm

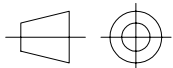
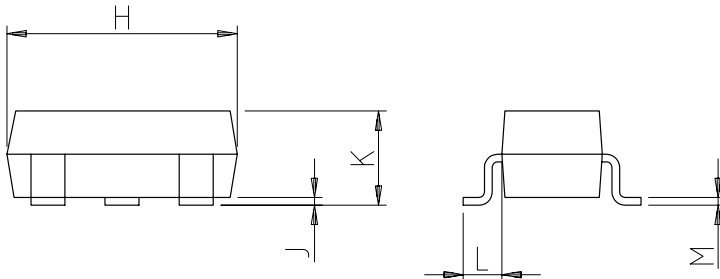

technical drawings
according to DIN
specifications

14384

SOT-23		
Dim	Min	Max
A	0.37	0.50
B	1.19	1.40
C	2.10	2.50
D	0.89	1.05
E	0.45	0.61
G	1.78	2.05
H	2.79	3.05
J	0.013	0.15
K	0.89	1.10
L	0.45	0.61
M	0.076	0.130
All Dimensions in mm		



Ozone Depleting Substances Policy Statement

It is the policy of **Vishay Semiconductor GmbH** to

1. Meet all present and future national and international statutory requirements.
2. Regularly and continuously improve the performance of our products, processes, distribution and operating systems with respect to their impact on the health and safety of our employees and the public, as well as their impact on the environment.

It is particular concern to control or eliminate releases of those substances into the atmosphere which are known as ozone depleting substances (ODSs).

The Montreal Protocol (1987) and its London Amendments (1990) intend to severely restrict the use of ODSs and forbid their use within the next ten years. Various national and international initiatives are pressing for an earlier ban on these substances.

Vishay Semiconductor GmbH has been able to use its policy of continuous improvements to eliminate the use of ODSs listed in the following documents.

1. Annex A, B and list of transitional substances of the Montreal Protocol and the London Amendments respectively
2. Class I and II ozone depleting substances in the Clean Air Act Amendments of 1990 by the Environmental Protection Agency (EPA) in the USA
3. Council Decision 88/540/EEC and 91/690/EEC Annex A, B and C (transitional substances) respectively.

Vishay Semiconductor GmbH can certify that our semiconductors are not manufactured with ozone depleting substances and do not contain such substances.

We reserve the right to make changes to improve technical design and may do so without further notice.

Parameters can vary in different applications. All operating parameters must be validated for each customer application by the customer. Should the buyer use Vishay-Semiconductors products for any unintended or unauthorized application, the buyer shall indemnify Vishay-Semiconductors against all claims, costs, damages, and expenses, arising out of, directly or indirectly, any claim of personal damage, injury or death associated with such unintended or unauthorized use.

Vishay Semiconductor GmbH, P.O.B. 3535, D-74025 Heilbronn, Germany
Telephone: 49 (0)7131 67 2831, Fax number: 49 (0)7131 67 2423