

## Low-Voltage Single SPDT Analog Switch

### FEATURES

- Low Voltage Operation (1.8 V to 5.5 V)
- Low On-Resistance -  $r_{DS(on)}$ : 7  $\Omega$
- Fast Switching -  $t_{ON}$ : 8 ns,  $t_{OFF}$ : 6 ns
- Low Charge Injection -  $Q_{INJ}$ : 5 pC
- Low Power Consumption
- TTL/CMOS Compatible
- 6-Pin SC-70 Package

### BENEFITS

- Reduced Power Consumption
- Simple Logic Interface
- High Accuracy
- Reduce Board Space

### APPLICATIONS

- Cellular Phones
- Communication Systems
- Portable Test Equipment
- Battery Operated Systems
- Sample and Hold Circuits

### DESCRIPTION

The DG2002 is a single-pole/double-throw monolithic CMOS analog switch designed for high performance switching of analog signals. Combining low power, high speed ( $t_{ON}$ : 8 ns,  $t_{OFF}$ : 6 ns), low on-resistance ( $r_{DS(on)}$ : 7  $\Omega$ ) and small physical size (SC70), the DG2002 is ideal for portable and battery powered applications requiring high performance and efficient use of board space.

The DG2002 is built on Vishay Siliconix's low voltage J12 process. An epitaxial layer prevents latchup. Break-before-make is guaranteed for DG2002.

Each switch conducts equally well in both directions when on, and blocks up to the power supply level when off.

### FUNCTIONAL BLOCK DIAGRAM AND PIN CONFIGURATION

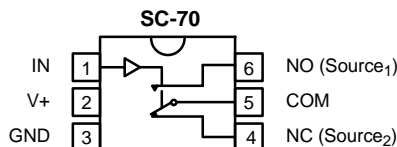

Top View

Device Marking: E2xx

#### TRUTH TABLE

Logic	NC	NO
0	ON	OFF
1	OFF	ON

#### ORDERING INFORMATION

Temp Range	Package	Part Number
-40 to 85°C	SC70-6	DG2002DL



**ABSOLUTE MAXIMUM RATINGS**

Reference to GND

V+	.....	-0.3 to +6 V
IN, COM, NC, NO <sup>a</sup>	.....	-0.3 to (V+ + 0.3 V)
Continuous Current (Any terminal)	.....	± 50 mA
Peak Current (Pulsed at 1 ms, 10% duty cycle)	.....	± 200 mA
Storage Temperature (D Suffix)	.....	-65 to 125°C

Power Dissipation (Packages)<sup>b</sup>

6-Pin SO70 <sup>c</sup>	.....	250 mW
-------------------------	-------	--------

- Notes:
- Signals on NC, NO, or COM or IN exceeding V+ will be clamped by internal diodes. Limit forward diode current to maximum current ratings.
  - All leads welded or soldered to PC Board.
  - Derate 6.5 mW/°C above 25°C

SPECIFICATIONS (V+ = 2.0 V)							
Parameter	Symbol	Test Conditions Otherwise Unless Specified V+ = 2.0 V, ± 10%, VIN = 0.4 or 1.6 V <sup>e</sup>	Temp <sup>a</sup>	Limits -40 to 85°C			Unit
				Min <sup>b</sup>	Typ <sup>c</sup>	Max <sup>b</sup>	
<b>Analog Switch</b>							
Analog Signal Range <sup>d</sup>	V <sub>NO</sub> , V <sub>NC</sub> , V <sub>COM</sub>		Full	0		V+	V
On-Resistance	r <sub>ON</sub>	V+ = 1.8 V, V <sub>COM</sub> = 1.0 V, I <sub>NO</sub> , I <sub>NC</sub> = 10 mA	Room Full <sup>d</sup>		38 39.3	46.1 47.1	Ω
r <sub>ON</sub> Flatness <sup>d</sup>	r <sub>ON</sub> Flatness	V+ = 1.8 V, V <sub>COM</sub> = 0 to V+, I <sub>NO</sub> , I <sub>NC</sub> = 10 mA	Room		21		
Switch Off Leakage Current <sup>f</sup>	I <sub>NO(off)</sub> , I <sub>NC(off)</sub>	V+ = 2.2 V V <sub>NO</sub> , V <sub>NC</sub> = 0.5 V/1.5 V, V <sub>COM</sub> = 1.5 V/0.5 V	Room Full <sup>d</sup>	-250 -3.0		250 3.0	pA nA
	I <sub>COM(off)</sub>		Room Full <sup>d</sup>	-250 -3.0		250 3.0	pA nA
Channel-On Leakage Current <sup>f</sup>	I <sub>COM(on)</sub>	V+ = 2.2 V, V <sub>NO</sub> , V <sub>NC</sub> = V <sub>COM</sub> = 0.5 V/1.5 V	Room Full <sup>d</sup>	-250 -3.0		250 3.0	pA nA
<b>Digital Control</b>							
Input High Voltage	V <sub>INH</sub>		Full	1.6			V
Input Low Voltage	V <sub>INL</sub>		Full			0.4	
Input Capacitance <sup>d</sup>	C <sub>in</sub>		Full		3		pF
Input Current	I <sub>INL</sub> or I <sub>INH</sub>	V <sub>IN</sub> = 0 or V+	Full	-1		1	μA
<b>Dynamic Characteristics</b>							
Turn-On Time	t <sub>ON</sub>	V <sub>NO</sub> or V <sub>NC</sub> = 1.5 V, R <sub>L</sub> = 300 Ω, C <sub>L</sub> = 35 pF Figures 1 and 2	Room Full <sup>d</sup>		22	31 32	ns
Turn-Off Time	t <sub>OFF</sub>		Room Full <sup>d</sup>		10	17 18	
Break-Before-Make Time	t <sub>d</sub>		Room	1	12		
Charge Injection <sup>d</sup>	Q <sub>INJ</sub>	C <sub>L</sub> = 1 nF, V <sub>GEN</sub> = 0 V, R <sub>GEN</sub> = 0 Ω, Figure 3	Room		5	10	pC
Off-Isolation <sup>d</sup>	OIRR	R <sub>L</sub> = 50 Ω, C <sub>L</sub> = 5 pF, f = 1 MHz	Room		-67		dB
Crosstalk <sup>d</sup>	X <sub>TALK</sub>		Room		-71		
NO, NC Off Capacitance <sup>d</sup>	C <sub>NO(off)</sub> , C <sub>NC(off)</sub>	V <sub>IN</sub> = 0 or V+, f = 1 MHz	Room		5		pF
Channel-On Capacitance <sup>d</sup>	C <sub>ON</sub>		Room		29		
<b>Power Supply</b>							
Power Supply Range	V+			1.8		2.2	V
Power Supply Current <sup>d</sup>	I+	V <sub>IN</sub> = 0 or V+			0.01	1.0	μA
Power Consumption	P <sub>C</sub>						2.2



SPECIFICATIONS (V+ = 3.0 V)							
Parameter	Symbol	Test Conditions Otherwise Unless Specified V+ = 3 V, ± 10%, VIN = 0.4 or 2.0 V <sup>e</sup>	Temp <sup>a</sup>	Limits -40 to 85°C			Unit
				Min <sup>b</sup>	Typ <sup>c</sup>	Max <sup>b</sup>	
<b>Analog Switch</b>							
Analog Signal Range <sup>d</sup>	V <sub>NO</sub> , V <sub>NC</sub> , V <sub>COM</sub>		Full	0		V+	V
On-Resistance <sup>d</sup>	r <sub>ON</sub>	V+ = 2.7 V, V <sub>COM</sub> = 1.5 V, I <sub>NO</sub> , I <sub>NC</sub> = 10 mA	Room Full		12.2 13	14.8 15.8	Ω
r <sub>ON</sub> Flatness <sup>d</sup>	r <sub>ON</sub> Flatness	V+ = 2.7 V, V <sub>COM</sub> = 0 to V+, I <sub>NO</sub> , I <sub>NC</sub> = 10 mA	Room		5		
Switch Off Leakage Current <sup>f</sup>	I <sub>NO(off)</sub> , I <sub>NC(off)</sub>	V+ = 3.3 V V <sub>NO</sub> , V <sub>NC</sub> = 1 V/3 V, V <sub>COM</sub> = 3 V/1 V	Room Full	-500 -4.0		500 4.0	pA nA
	I <sub>COM(off)</sub>		Room Full	-500 -4.0		500 4.0	pA nA
Channel-On Leakage Current <sup>f</sup>	I <sub>COM(on)</sub>	V+ = 3.3 V, V <sub>NO</sub> , V <sub>NC</sub> = V <sub>COM</sub> = 1 V/3 V	Room Full	-500 -4.0		500 4.0	pA nA
<b>Digital Control</b>							
Input High Voltage	V <sub>INH</sub>		Full	2			V
Input Low Voltage	V <sub>INL</sub>		Full			0.4	
Input Capacitance <sup>d</sup>	C <sub>in</sub>		Full		3		pF
Input Current	I <sub>INL</sub> or I <sub>INH</sub>	V <sub>IN</sub> = 0 or V+	Full	-1		1	μA
<b>Dynamic Characteristics</b>							
Turn-On Time <sup>d</sup>	t <sub>ON</sub>	V <sub>NO</sub> or V <sub>NC</sub> = 2.0 V, R <sub>L</sub> = 300 Ω, C <sub>L</sub> = 35 pF Figure 1 and 2	Room Full		12	21 22	ns
Turn-Off Time <sup>d</sup>	t <sub>OFF</sub>		Room Full		7	14 15	
Break-Before-Make Time <sup>d</sup>	t <sub>d</sub>		Room	1	6		
Charge Injection <sup>d</sup>	Q <sub>INJ</sub>	C <sub>L</sub> = 1 nF, V <sub>GEN</sub> = 0 V, R <sub>GEN</sub> = 0 Ω, Figure 3	Room		5	10	pC
Off-Isolation <sup>d</sup>	OIRR	R <sub>L</sub> = 50 Ω, C <sub>L</sub> = 5 pF, f = 1 MHz	Room		-67		dB
Crosstalk <sup>d</sup>	X <sub>TALK</sub>		Room		-69		
NO, NC Off Capacitance <sup>d</sup>	C <sub>NO(off)</sub> , C <sub>NC(off)</sub>	V <sub>IN</sub> = 0 or V+, f = 1 MHz	Room		5		pF
Channel-On Capacitance <sup>d</sup>	C <sub>ON</sub>		Room		29		
<b>Power Supply</b>							
Power Supply Range	V+			2.7		3.3	V
Power Supply Current	I+	V <sub>IN</sub> = 0 or V+			0.01	1.0	μA
Power Consumption	P <sub>C</sub>						3.3



SPECIFICATIONS (V+ = 5.0 V)							
Parameter	Symbol	Test Conditions Otherwise Unless Specified V+ = 5 V, ± 10%, VIN = 0.8 or 2.4 V <sup>e</sup>	Temp <sup>a</sup>	Limits -40 to 85°C			Unit
				Min <sup>b</sup>	Typ <sup>c</sup>	Max <sup>b</sup>	
<b>Analog Switch</b>							
Analog Signal Range <sup>d</sup>	V <sub>NO</sub> , V <sub>NC</sub> , V <sub>COM</sub>		Full	0		V+	V
On-Resistance	r <sub>ON</sub>	V+ = 4.5 V, V <sub>COM</sub> = 3 V, I <sub>NO</sub> , I <sub>NC</sub> = 10 mA	Room Full		6.4 7.4	7.8 8.8	Ω
r <sub>ON</sub> Flatness <sup>d</sup>	r <sub>ON</sub> Flatness	V+ = 4.5 V, V <sub>COM</sub> = 0 to V+, I <sub>NO</sub> , I <sub>NC</sub> = 10 mA	Room		3		
Switch Off Leakage Current	I <sub>NO(off)</sub> , I <sub>NC(off)</sub>	V+ = 5.5 V V <sub>NO</sub> , V <sub>NC</sub> = 1 V/4.5 V, V <sub>COM</sub> = 4.5 V/1 V	Room Full	-1.0 -4.0		1.0 4.0	nA
	I <sub>COM(off)</sub>		Room Full	-1.0 -4.0		1.0 4.0	
Channel-On Leakage Current	I <sub>COM(on)</sub>	V+ = 5.5 V, V+ = 5.5 V V <sub>NO</sub> , V <sub>NC</sub> = V <sub>COM</sub> = 1 V/4.5 V	Room Full	-1.0 -4.5		1.0 4.5	
<b>Digital Control</b>							
Input High Voltage	V <sub>INH</sub>		Full	2.4			V
Input Low Voltage	V <sub>INL</sub>		Full			0.8	
Input Capacitance	C <sub>in</sub>		Full		3		pF
Input Current	I <sub>INL</sub> or I <sub>INH</sub>	V <sub>IN</sub> = 0 or V+	Full	-1		1	μA
<b>Dynamic Characteristics</b>							
Turn-On Time <sup>d</sup>	t <sub>ON</sub>	V <sub>NO</sub> or V <sub>NC</sub> = 3 V, R <sub>L</sub> = 300 Ω, C <sub>L</sub> = 35 pF Figure 1 and 2	Room Full		8	15 16	ns
Turn-Off Time <sup>d</sup>	t <sub>OFF</sub>		Room Full		6	13 14	
Break-Before-Make Time <sup>d</sup>	t <sub>d</sub>		Room	1	4		
Charge Injection <sup>d</sup>	Q <sub>INJ</sub>	C <sub>L</sub> = 1 nF, V <sub>GEN</sub> = 0 V, R <sub>GEN</sub> = 0 Ω, Figure 3	Room		5	10	pC
Off-Isolation <sup>d</sup>	OIRR	R <sub>L</sub> = 50 Ω, C <sub>L</sub> = 5 pF, f = 1 MHz	Room		-69		dB
Crosstalk <sup>d</sup>	X <sub>TALK</sub>		Room		-69		
Source-Off Capacitance <sup>d</sup>	C <sub>NO(off)</sub> , C <sub>NC(off)</sub>	V <sub>IN</sub> = 0 or V+, f = 1 MHz	Room		5		pF
Channel-On Capacitance <sup>d</sup>	C <sub>ON</sub>		Room		29		
<b>Power Supply</b>							
Power Supply Range	V+			4.5		5.5	V
Power Supply Current	I+	V <sub>IN</sub> = 0 or V+			0.01	1.0	μA
Power Consumption	P <sub>C</sub>						5.5

Notes:

- a. Room = 25°C, Full = as determined by the operating suffix.
- b. The algebraic convention whereby the most negative value is a minimum and the most positive a maximum, is used in this data sheet.
- c. Typical values are for design aid only, not guaranteed nor subject to production testing.
- d. Guarantee by design, nor subjected to production test.
- e. V<sub>IN</sub> = input voltage to perform proper function.
- f. Guaranteed by 5-V leakage testing, not production tested.

**TYPICAL CHARACTERISTICS (25°C UNLESS NOTED)**

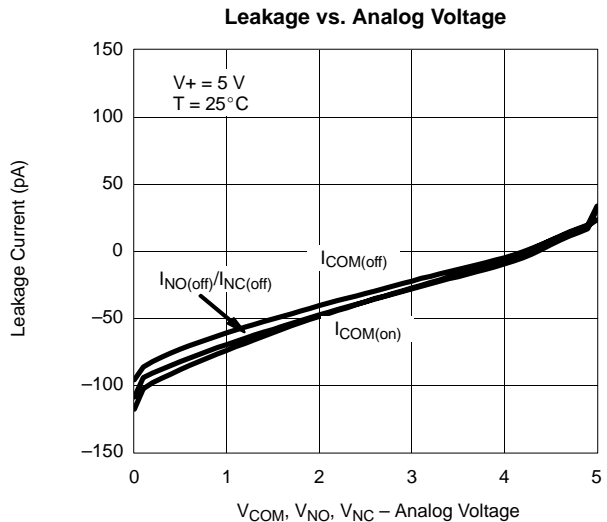
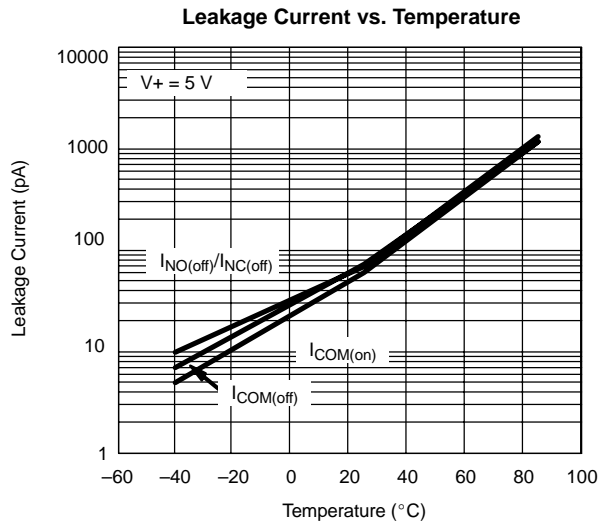
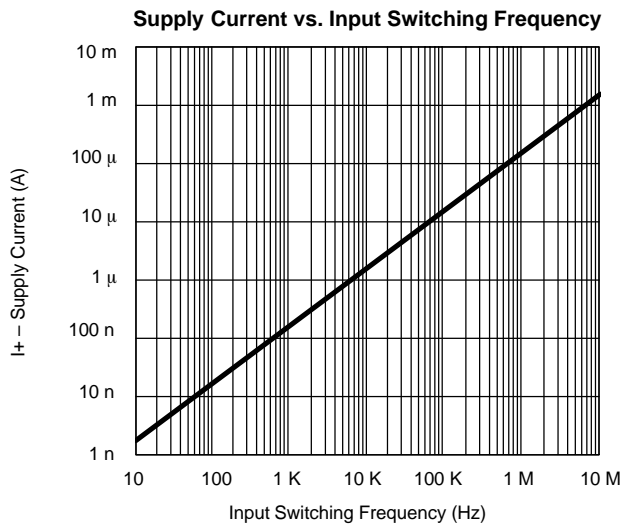
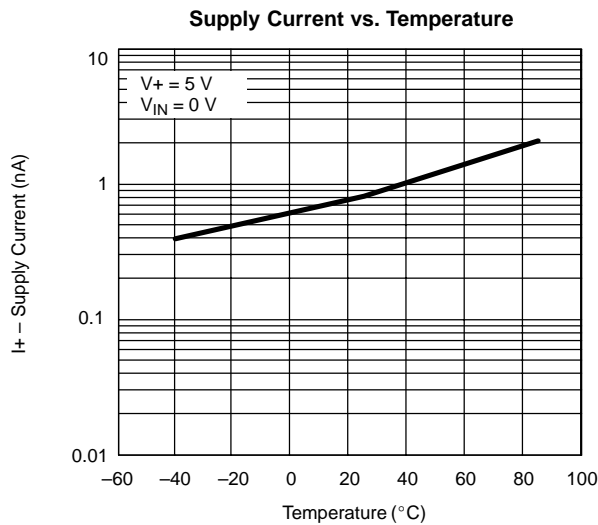
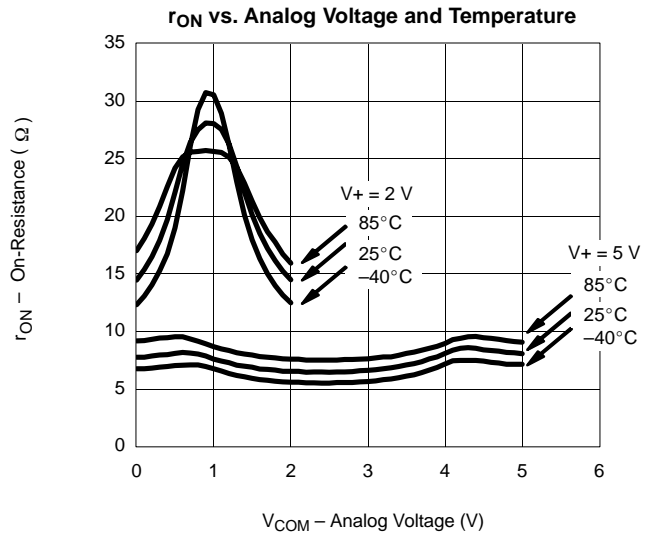
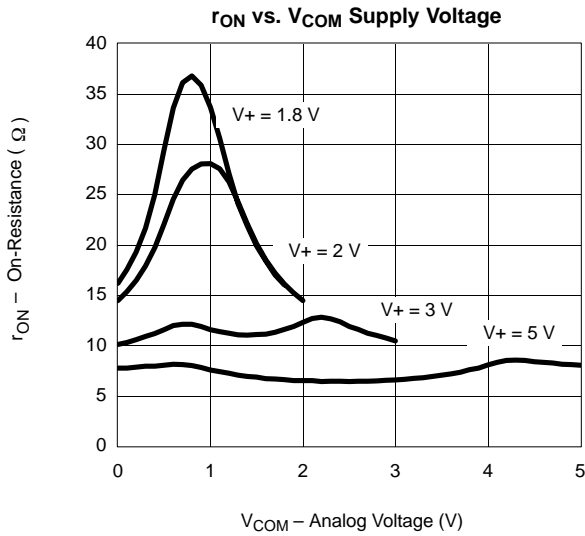



**TYPICAL CHARACTERISTICS (25°C UNLESS NOTED)**

Switching Time vs. Temperature and Supply Voltage

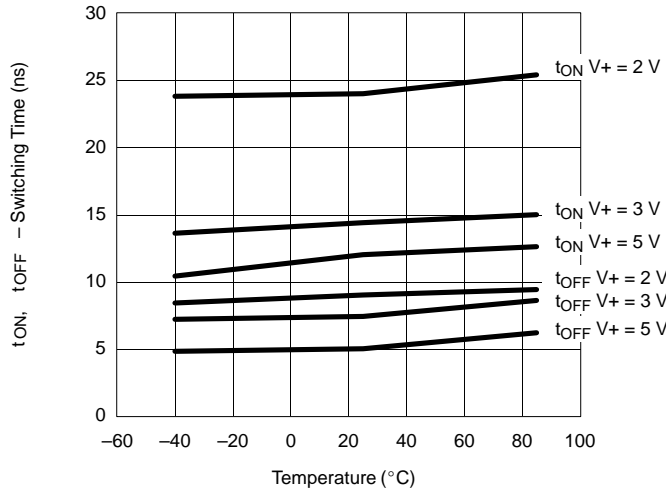

Insertion Loss, Off-Isolation, Crosstalk vs. Frequency

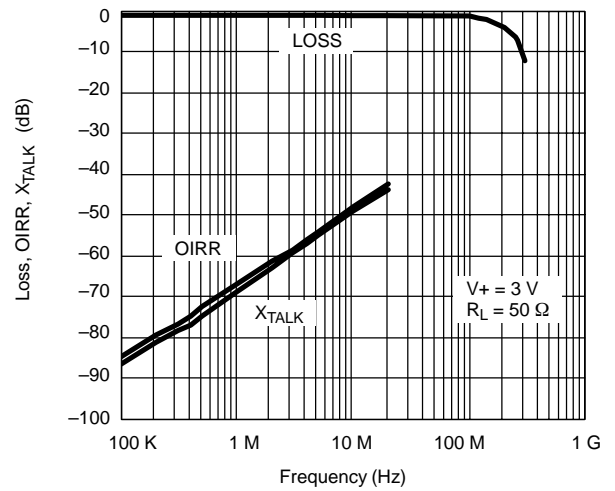

Switching Threshold vs. Supply Voltage

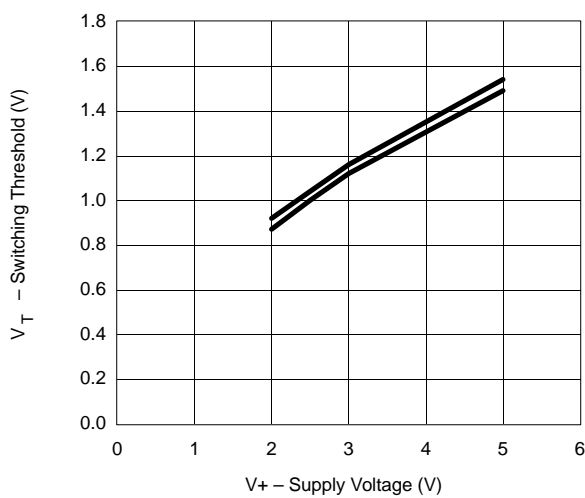

Charge Injection vs. Analog Voltage

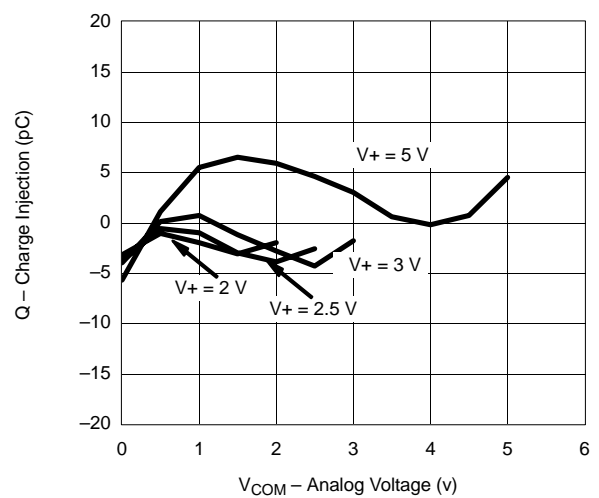

TEST CIRCUITS

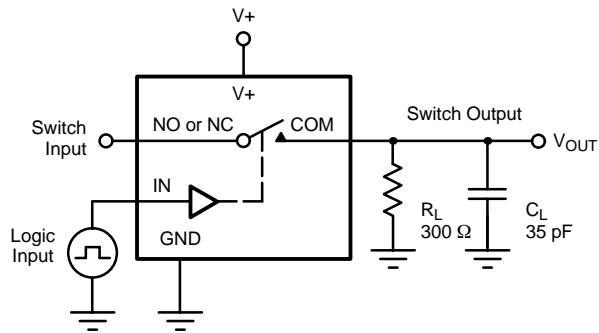

$C_L$  (includes fixture and stray capacitance)

$$V_{OUT} = V_{COM} \left( \frac{R_L}{R_L + R_{ON}} \right)$$

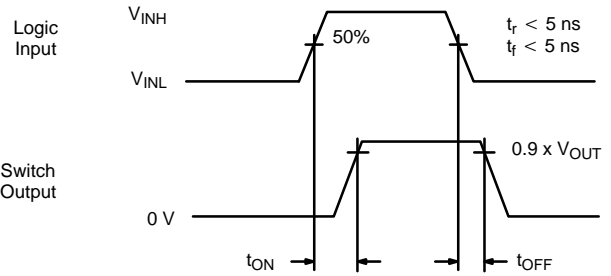

Logic "1" = Switch On  
Logic input waveforms inverted for switches that have the opposite logic sense.

FIGURE 1. Switching Time

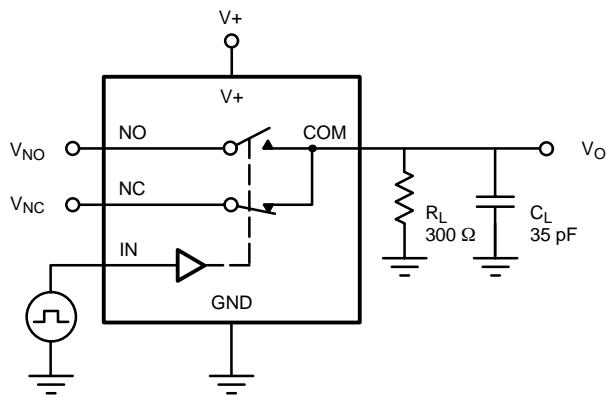

$C_L$  (includes fixture and stray capacitance)

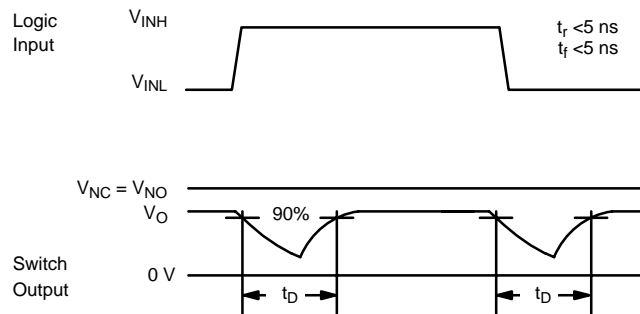
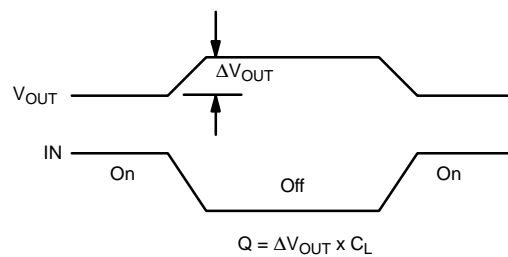
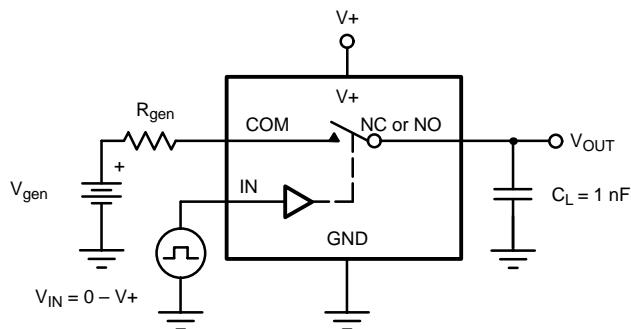

FIGURE 2. Break-Before-Make Interval



IN depends on switch configuration: input polarity determined by sense of switch.

FIGURE 3. Charge Injection

**TEST CIRCUITS**

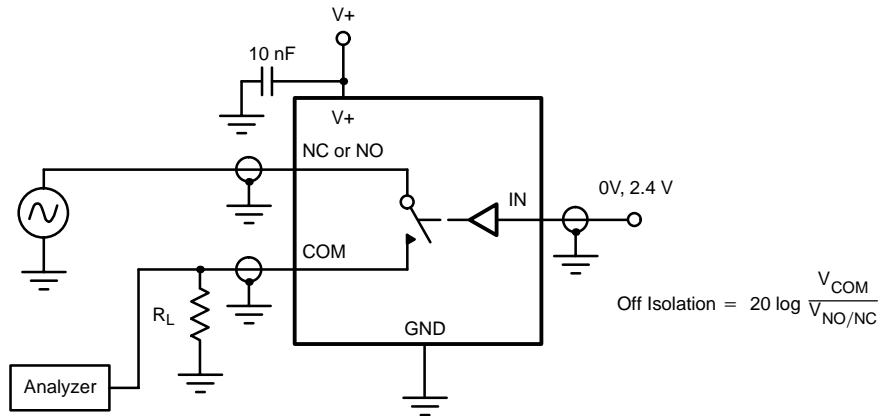

FIGURE 4. Off-Isolation

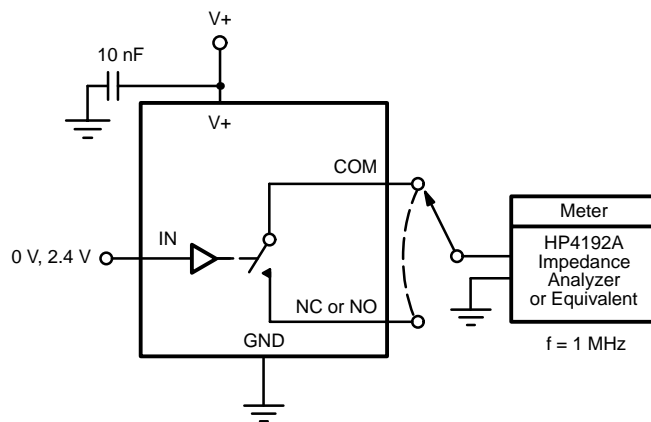

FIGURE 5. Channel Off/On Capacitance