



Low-Voltage Dual SPST Analog Switch

FEATURES

- Low Voltage Operation (1.8 V to 5.5 V)
- Low On-Resistance - $r_{DS(on)}$: 1.2 Ω
- Fast Switching - 14 ns
- Low Charge Injection - Q_{INJ} : 1 pC
- Low Power Consumption
- TTL/CMOS Compatible
- MSOP-8 Package

BENEFITS

- Reduced Power Consumption
- Simple Logic Interface
- High Accuracy
- Reduce Board Space

APPLICATIONS

- Cellular Phones
- Communication Systems
- Portable Test Equipment
- Battery Operated Systems
- Sample and Hold Circuits

DESCRIPTION

The DG2003/2004/2005 are dual single-pole/single-throw monolithic CMOS analog switch designed for high performance switching of analog signals. Combining low power, fast switching, low on-resistance ($r_{DS(on)}$: 1.2 Ω) and small physical size (MSOP-8), the DG2003/2004/2005 are ideal for portable and battery powered applications requiring high performance and efficient use of board space.

The DG2003/2004/2005 are built on Vishay Siliconix's low voltage J12 process. An epitaxial layer prevents latchup.

Each switch conducts equally well in both directions when on, and blocks up to the power supply level when off.

FUNCTIONAL BLOCK DIAGRAM AND PIN CONFIGURATION

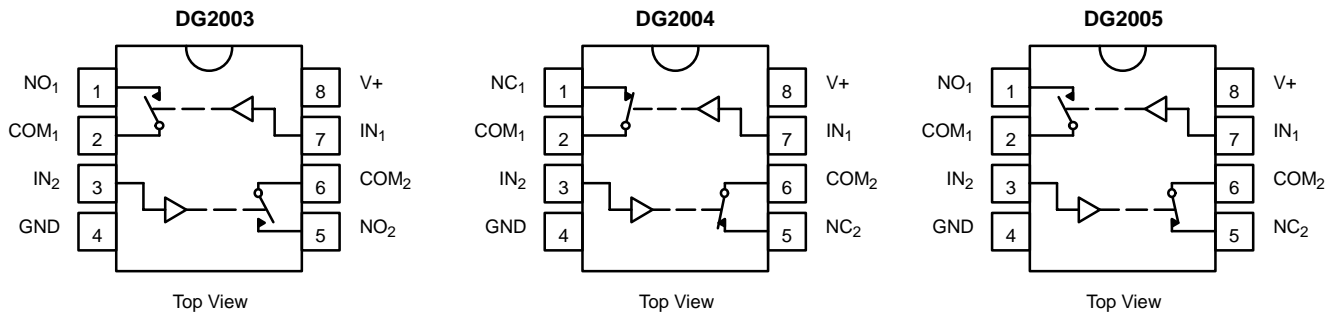

TRUTH TABLE - DG2003	
Logic	NO
0	Off
1	On

TRUTH TABLE - DG2004	
Logic	NC
0	On
1	Off

TRUTH TABLE - DG2005		
Logic	NO ₁	NC ₂
0	Off	On
1	On	Off

ORDERING INFORMATION		
Temp Range	Package	Part Number
-40 to 85°C	MSOP-8	DG2003DQ
		DG2004DQ
		DG2005DQ



ABSOLUTE MAXIMUM RATINGS

Reference to GND

V+	-0.3 to +6 V
IN, COM, NC, NO ³	-0.3 to (V+ + 0.3 V)
Continuous Current (Any terminal)	±50 mA
Peak Current (Pulsed at 1 ms, 10% duty cycle)	±200 mA
Storage Temperature (D Suffix)	-65 to 150°C

Power Dissipation (Packages)^b

MSOP-8 ^c	320 mW
---------------------	-------	--------

- Notes:
- Signals on NC, NO, or COM or IN exceeding V+ will be clamped by internal diodes. Limit forward diode current to maximum current ratings.
 - All leads welded or soldered to PC Board.
 - Derate 6.5 mW/°C above 25°C

SPECIFICATIONS (V+ = 2.0 V)							
Parameter	Symbol	Test Conditions Otherwise Unless Specified V+ = 2.0 V, ±10%, V _{IN} = 0.4 or 1.6 V ^e	Temp ^a	Limits -40 to 85°C			Unit
				Min ^b	Typ ^c	Max ^b	
Analog Switch							
Analog Signal Range ^d	V _{NO} , V _{NC} , V _{COM}		Full	0		V+	V
On-Resistance	r _{ON}	V+ = 2.0 V, V _{COM} = 1.0 V, I _{NO} , I _{NC} = 1 mA	Room Full ^d		7.0 12.5	10.0 16.0	Ω
r _{ON} Flatness ^d	r _{ON} Flatness	V+ = 2.0 V, V _{COM} = 0 to V+, I _{NO} , I _{NC} = 1 mA	Room		5		
Switch Off Leakage Current ^f	I _{NO(off)} , I _{NC(off)}	V+ = 2.2 V V _{NO} , V _{NC} = 0.5 V/1.5 V, V _{COM} = 1.5 V/0.5 V	Room Full ^d	-500 -4.0		500 4.0	pA nA
	I _{COM(off)}		Room Full ^d	-500 -4.0		500 4.0	pA nA
Channel-On Leakage Current ^f	I _{COM(on)}	V+ = 2.2 V, V _{NO} , V _{NC} = V _{COM} = 0.5 V/1.5 V	Room Full ^d	-500 -4.0		500 4.0	pA nA
Digital Control							
Input High Voltage	V _{INH}		Full	1.6			V
Input Low Voltage	V _{INL}		Full			0.4	
Input Capacitance ^d	C _{in}		Full		5		pF
Input Current	I _{INL} or I _{INH}	V _{IN} = 0 or V+	Full	-1		1	μA
Dynamic Characteristics							
Turn-On Time	t _{ON}	V _{NO} or V _{NC} = 1.5 V, R _L = 300 Ω, C _L = 35 pF Figures 1 and 2	Room Full ^d		30	47 48	ns
Turn-Off Time	t _{OFF}		Room Full ^d		22	37 48	
Charge Injection ^d	Q _{INJ}	C _L = 1 nF, V _{GEN} = 0 V, R _{GEN} = 0 Ω, Figure 3	Room		2		pC
Off-Isolation ^d	OIRR	R _L = 50 Ω, C _L = 5 pF, f = 1 MHz	Room		-61		dB
Crosstalk ^d	X _{TALK}		Room		-67		
NO, NC Off Capacitance ^d	C _{NO(off)} , C _{NC(off)}	V _{IN} = 0 or V+, f = 1 MHz	Room		53		pF
Channel-On Capacitance ^d	C _{ON}		Room		110		
Power Supply							
Power Supply Range	V+			1.8		2.2	V
Power Supply Current ^d	I+	V _{IN} = 0 or V+			0.02	1.0	μA
Power Consumption	P _C						2.2



SPECIFICATIONS (V+ = 3.0 V)							
Parameter	Symbol	Test Conditions Otherwise Unless Specified V+ = 3 V, ± 10%, VIN = 0.4 or 2.0 V ^e	Temp ^a	Limits -40 to 85°C			Unit
				Min ^b	Typ ^c	Max ^b	
Analog Switch							
Analog Signal Range ^d	V _{NO} , V _{NC} , V _{COM}		Full	0		V+	V
On-Resistance	r _{ON}	V+ = 2.7 V, V _{COM} = 1.5 V, I _{NO} , I _{NC} = 10 mA	Room Full		2.2 2.4	3.5 3.7	Ω
r _{ON} Flatness ^d	r _{ON} Flatness	V+ = 2.7 V, V _{COM} = 0 to V+, I _{NO} , I _{NC} = 10 mA	Room		0.5		
Switch Off Leakage Current ^f	I _{NO(off)} , I _{NC(off)}	V+ = 3.3 V V _{NO} , V _{NC} = 1 V/3 V, V _{COM} = 3 V/1 V	Room Full	-500 -6.0		500 6.0	pA nA
	I _{COM(off)}		Room Full	-500 -6.0		500 6.0	pA nA
Channel-On Leakage Current ^f	I _{COM(on)}	V+ = 3.3 V, V _{NO} , V _{NC} = V _{COM} = 1 V/3 V	Room Full	-500 -6.0		500 6.0	pA nA
Digital Control							
Input High Voltage	V _{INH}		Full	2			V
Input Low Voltage	V _{INL}		Full			0.4	
Input Capacitance ^d	C _{in}		Full		5		pF
Input Current	I _{INL} or I _{INH}	V _{IN} = 0 or V+	Full	-1		1	μA
Dynamic Characteristics							
Turn-On Time ^d	t _{ON}	V _{NO} or V _{NC} = 2.0 V, R _L = 300 Ω, C _L = 35 pF Figure 1 and 2	Room Full		19	35 36	ns
Turn-Off Time ^d	t _{OFF}		Room Full		17	31 34	
Charge Injection ^d	Q _{INJ}	C _L = 1 nF, V _{GEN} = 0 V, R _{GEN} = 0 Ω, Figure 3	Room		1		pC
Off-Isolation ^d	OIRR	R _L = 50 Ω, C _L = 5 pF, f = 1 MHz	Room		-61		dB
Crosstalk ^d	X _{TALK}		Room		-67		
NO, NC Off Capacitance ^d	C _{NO(off)} , C _{NC(off)}	V _{IN} = 0 or V+, f = 1 MHz	Room		53		pF
Channel-On Capacitance ^d	C _{ON}		Room		110		
Power Supply							
Power Supply Range	V+			2.7		3.3	V
Power Supply Current	I+	V _{IN} = 0 or V+			0.02	1.0	μA
Power Consumption	P _C						3.3



SPECIFICATIONS (V+ = 5.0 V)							
Parameter	Symbol	Test Conditions Otherwise Unless Specified V+ = 5 V, ± 10%, VIN = 0.8 or 2.4 V ^e	Temp ^a	Limits -40 to 85°C			Unit
				Min ^b	Typ ^c	Max ^b	
Analog Switch							
Analog Signal Range ^d	V _{NO} , V _{NC} , V _{COM}		Full	0		V+	V
On-Resistance	r _{ON}	V+ = 4.5 V, V _{COM} = 3 V, I _{NO} , I _{NC} = 10 mA	Room Full		1.2 1.6	2.5 2.7	Ω
r _{ON} Flatness ^d	r _{ON} Flatness	V+ = 4.5 V, V _{COM} = 0 to V+, I _{NO} , I _{NC} = 10 mA	Room		0.2		
Switch Off Leakage Current	I _{NO(off)} , I _{NC(off)}	V+ = 5.5 V V _{NO} , V _{NC} = 1 V/4.5 V, V _{COM} = 4.5 V/1 V	Room Full	-1.0 -8.0		1.0 8.0	nA
	I _{COM(off)}		Room Full	-1.0 -8.0		1.0 8.0	
Channel-On Leakage Current	I _{COM(on)}	V+ = 5.5 V, V+ = 5.5 V V _{NO} , V _{NC} = V _{COM} = 1 V/4.5 V	Room Full	-1.0 -8.0		1.0 8.0	
Digital Control							
Input High Voltage	V _{INH}		Full	2.4			V
Input Low Voltage	V _{INL}		Full			0.8	
Input Capacitance	C _{in}		Full		5		pF
Input Current	I _{INL} or I _{INH}	V _{IN} = 0 or V+	Full	-1		1	μA
Dynamic Characteristics							
Turn-On Time ^d	t _{ON}	V _{NO} or V _{NC} = 3 V, R _L = 300 Ω, C _L = 35 pF Figure 1 and 2	Room Full		13	28 31	ns
Turn-Off Time ^d	t _{OFF}		Room Full		19	22 31	
Charge Injection ^d	Q _{INJ}	C _L = 1 nF, V _{GEN} = 0 V, R _{GEN} = 0 Ω, Figure 3	Room		1		pC
Off-Isolation ^d	OIRR	R _L = 50 Ω, C _L = 5 pF, f = 1 MHz	Room		-61		dB
Crosstalk ^d	X _{TALK}		Room		-67		
Source-Off Capacitance ^d	C _{NO(off)} , C _{NC(off)}	V _{IN} = 0 or V+, f = 1 MHz	Room		51		pF
Channel-On Capacitance ^d	C _{ON}		Room		110		
Power Supply							
Power Supply Range	V+			4.5		5.5	V
Power Supply Current	I+	V _{IN} = 0 or V+			0.02	1.0	μA
Power Consumption	P _C						5.5

Notes:

- Room = 25°C, Full = as determined by the operating suffix.
- The algebraic convention whereby the most negative value is a minimum and the most positive a maximum, is used in this data sheet.
- Typical values are for design aid only, not guaranteed nor subject to production testing.
- Guarantee by design, nor subjected to production test.
- V_{IN} = input voltage to perform proper function.
- Guaranteed by 5-V leakage testing, not production tested.



TYPICAL CHARACTERISTICS (25°C UNLESS NOTED)

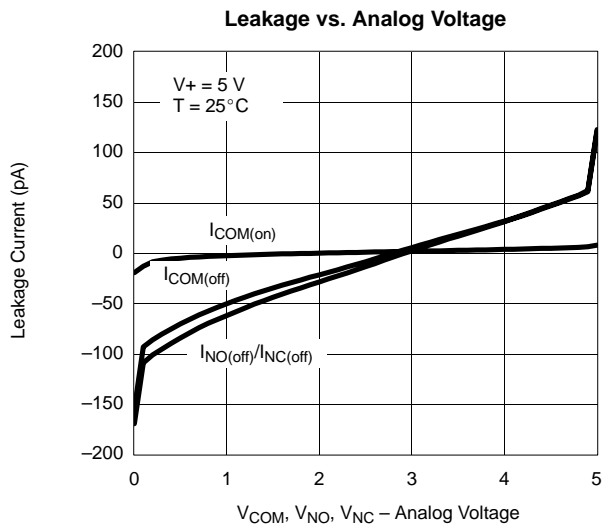
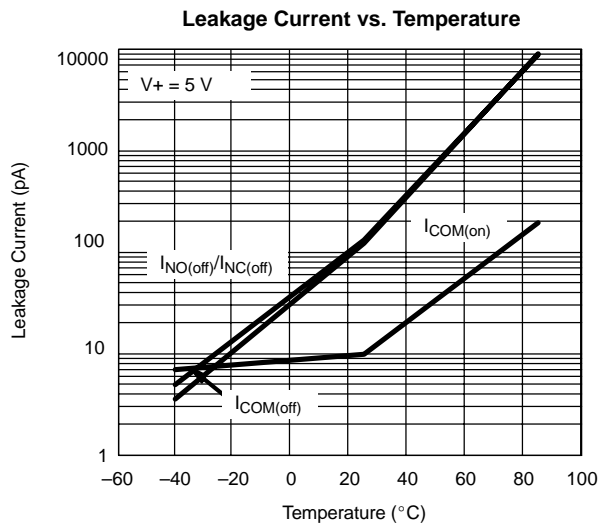
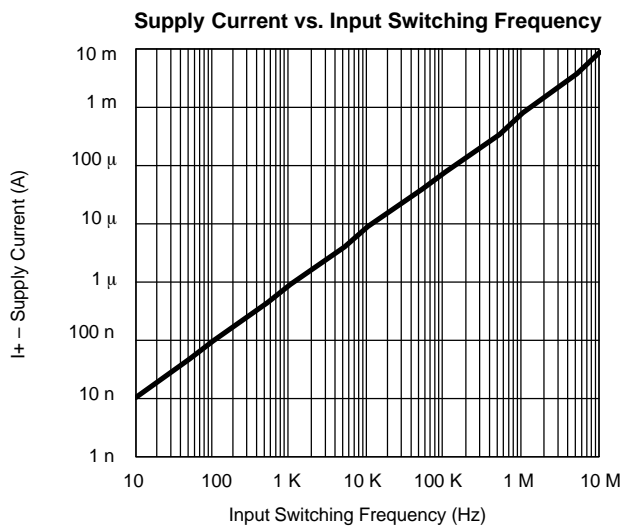
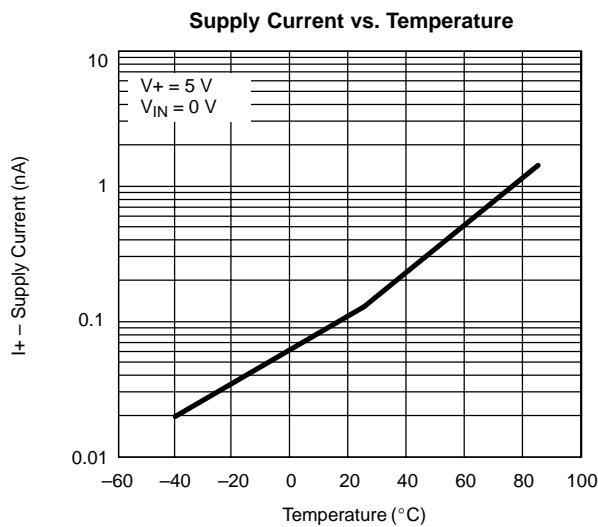
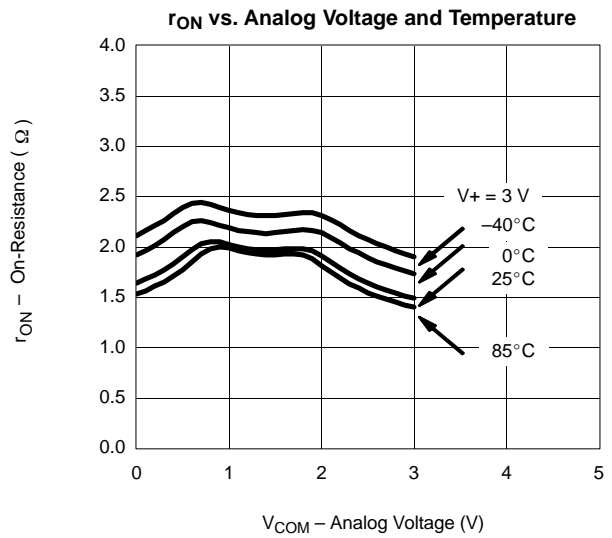
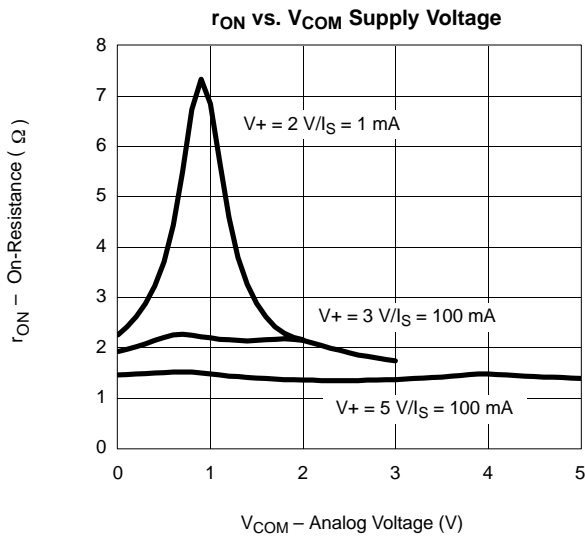



TYPICAL CHARACTERISTICS (25°C UNLESS NOTED)

Switching Time vs. Temperature and Supply Voltage

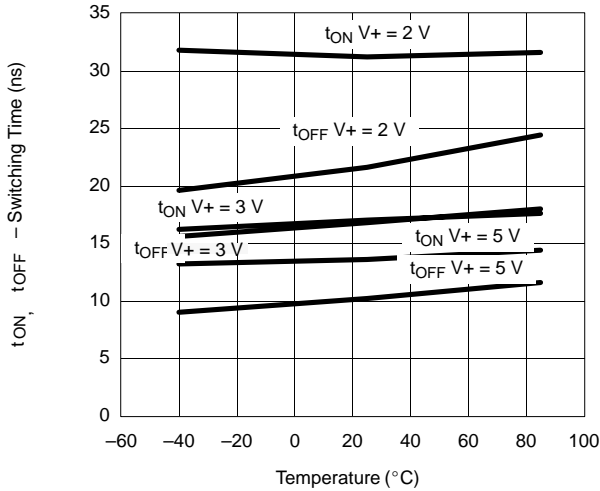

Insertion Loss, Off-Isolation, Crosstalk vs. Frequency

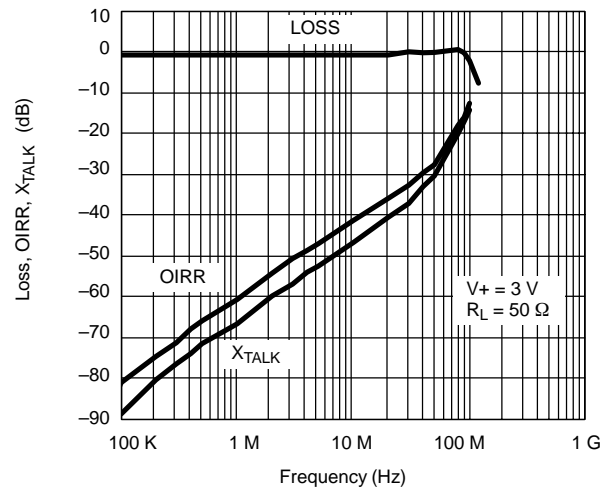

Switching Threshold vs. Supply Voltage

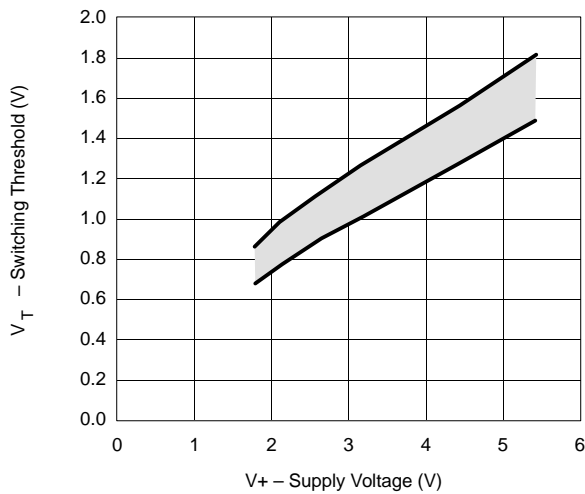

Charge Injection vs. Analog Voltage

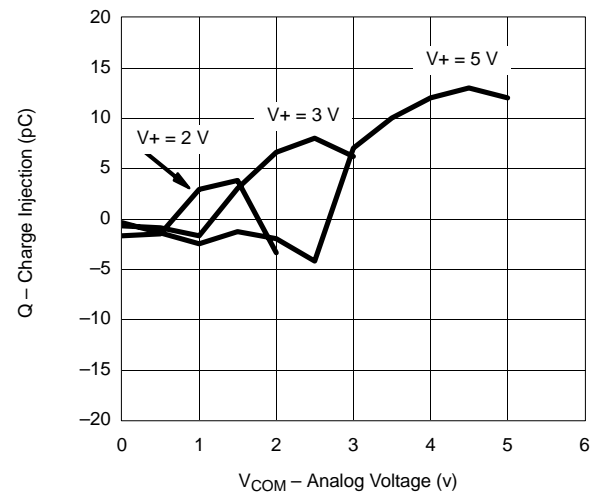

TEST CIRCUITS

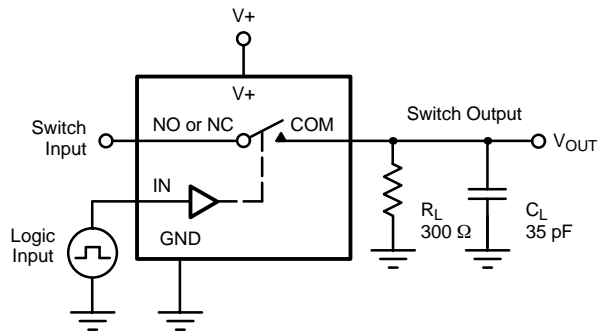

C_L (includes fixture and stray capacitance)

$$V_{OUT} = V_{COM} \left(\frac{R_L}{R_L + R_{ON}} \right)$$

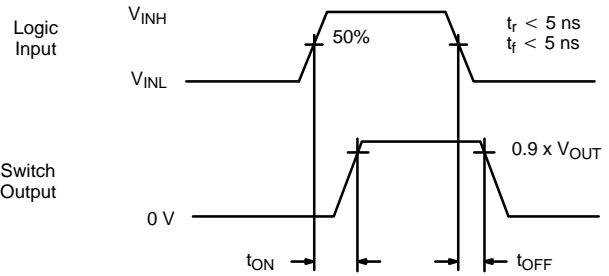

Logic "1" = Switch On
 Logic input waveforms inverted for switches that have the opposite logic sense.

FIGURE 1. Switching Time

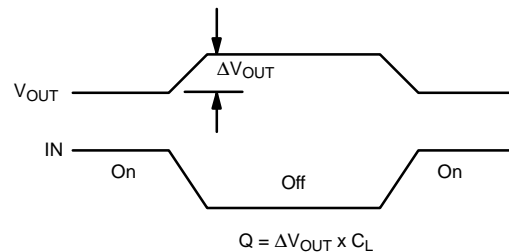
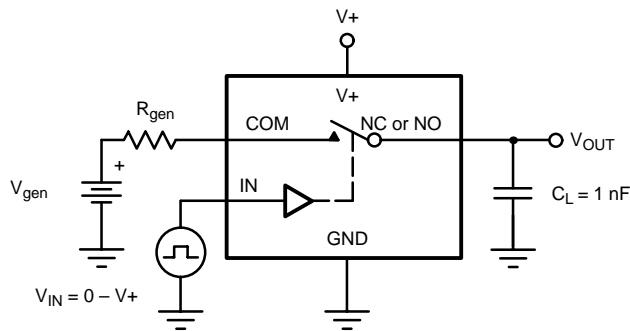

IN depends on switch configuration: input polarity determined by sense of switch.

FIGURE 2. Charge Injection

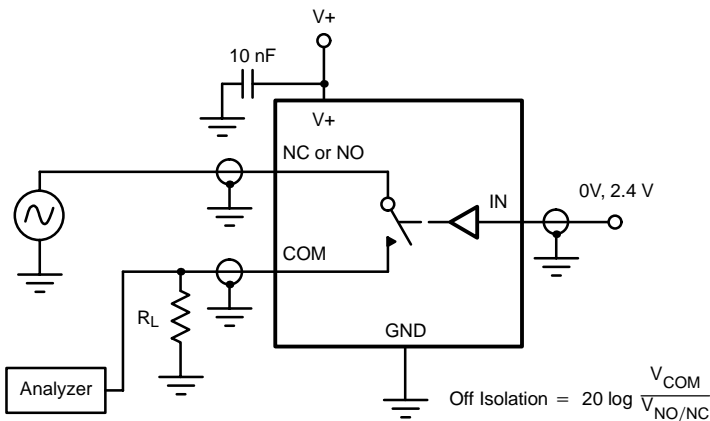

FIGURE 3. Off-Isolation

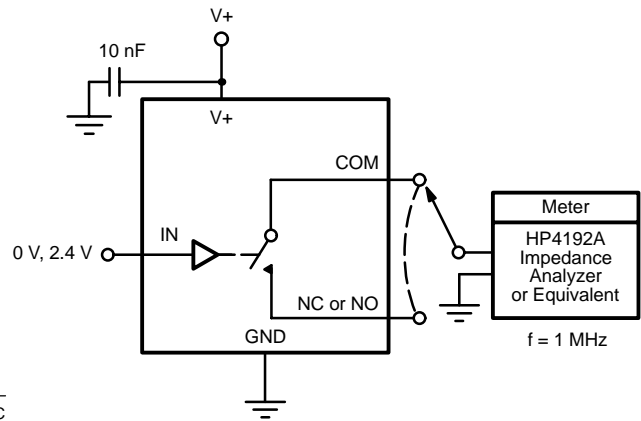

FIGURE 4. Channel Off/On Capacitance