



Low-Voltage Single-Supply, SPDT Analog Switch in SC-70

FEATURES

- 6-Pin SC-70 Package
- 60-Ω Max. (26 Typ.) On-Resistance
- 2-Ω Typ. R_{ON} Flatness
- Fast Switching: t_{ON} = 30 ns (Max.)
t_{OFF} = 25 ns (Max.)
- 2.25-V to 5.5-V Single Supply Operation
- Break-Before-Make Switching
- TTL/CMOS-Logic Compatible

BENEFITS

- Reduced Power Consumption
- Simple Logic Interface
- High Accuracy
- Reduce Board Space

APPLICATIONS

- Battery-Operated Equipment
- Audio and Video Signal Routing
- Cellular Phones
- Low-Voltage Data-Acquisition Systems
- Sample-and-Hold Circuits
- Communications Systems

DESCRIPTION

The DG4599 is a cost effective upgrade to other types of 4599 low-voltage, single-pole/double-throw analog switches available in the industry today.

The DG4599 is built on Vishay Siliconix's low voltage CMOS process. An epitaxial layer prevents latchup. Break-before-make is guaranteed for DG4599.

Combining low power, high speed, low on-resistance and small physical size, the DG4599 is ideal for portable and battery powered applications.

Each switch conducts equally well in both directions when on, and blocks up to the power supply level when off.

FUNCTIONAL BLOCK DIAGRAM AND PIN CONFIGURATION

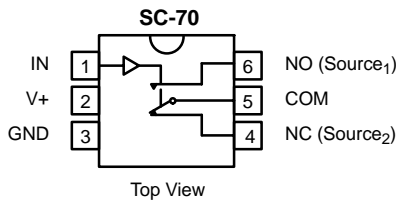

Device Marking: 4J

TRUTH TABLE		
Logic	NC	NO
0	ON	OFF
1	OFF	ON

Logic "0" ≤ 0.8 V
Logic "1" ≥ 2.4 V

ORDERING INFORMATION		
Temp Range	Package	Part Number
-40 to 85°C	SC70-6	DG4599DL



ABSOLUTE MAXIMUM RATINGS

Reference to GND

V+	-0.3 to +6 V
IN, COM, NC, NO ^a	-0.3 to (V+ + 0.3 V)
Continuous Current (Any terminal)	± 50 mA
Peak Current (Pulsed at 1 ms, 10% duty cycle)	± 200 mA
Storage Temperature (D Suffix)	-65 to 125°C

Power Dissipation (Packages) ^b	
6-Pin SO70° 250 mW

- Notes:
- Signals on NC, NO, or COM or IN exceeding V+ will be clamped by internal diodes. Limit forward diode current to maximum current ratings.
 - All leads welded or soldered to PC Board.
 - Derate 6.5 mW/°C above 75°C

SPECIFICATIONS (V+ = 5 V)							
Parameter	Symbol	Test Conditions Otherwise Unless Specified V+ = 5 V, ± 10%, V _{IN} = 0.8 or 2.4 V ^e	Temp ^a	Limits -40 to 85°C			Unit
				Min ^b	Typ ^c	Max ^b	
Analog Switch							
Analog Signal Range ^d	V _{NO} , V _{NC} , V _{COM}		Full	0		V+	V
Drain-Source On-Resistance	r _{DS(on)}	V+ = 4.5 V, V _D = 3 V, I _S = 10 mA	Room Full		7 10	60 65	Ω
r _{DS(on)} Flatness ^d	r _{DS(on)} Flatness	V+ = 2.5 V	Room		2		
Switch Off Leakage Current	I _{S(off)}	V+ = 5.5 V V _S = 1 V/4.5 V, V _D = 4.5 V/1 V	Room Full	-1.0 -4.0		1.0 4.0	nA
	I _{D(off)}		Room Full	-1.0 -4.0		1.0 4.0	
Channel-On Leakage Current	I _{D(on)}	V+ = 5.5 V, V _S = V _D = 1 V/4.5 V	Room Full	-1.0 -3.0		1.0 4.5	
Digital Control							
Input High Voltage	V _{INH}		Full	2.4			V
Input Low Voltage	V _{INL}		Full			0.8	
Input Capacitance	C _{in}		Full		3		pF
Input Current	I _{INL} or I _{INH}	V _{IN} = 0 or V+	Full	-1		1	μA
Dynamic Characteristics							
Turn-On Time ^d	t _{ON}	V _D or V _S = 3 V, R _L = 300 Ω, C _L = 35 pF Figure 1 and 2	Room Full		9	30 40	ns
Turn-Off Time ^d	t _{OFF}		Room Full		5	25 30	
Break-Before-Make Time ^d	t _d		Room	1	4		
Charge Injection ^d	Q _{INJ}	C _L = 1 nF, V _S = 0 V V _{GEN} = 0 V, R _{GEN} = 0 Ω, Figure 3	Room		5	10	pC
Off-Isolation ^d	OIRR	R _L = 50 Ω, C _L = 5 pF, f = 1 MHz	Room		-73		dB
Crosstalk ^d	X _{TALK}		Room		-70		
Source-Off Capacitance ^d	C _{S(off)}	V _{IN} = 0 or V+, f = 1 MHz	Room		7		pF
Channel-On Capacitance ^d	C _{D(on)}		Room		20		
Drain-to-Source Capacitance ^d	C _{DS(off)}		Room		20		
Power Supply							
Power Supply Range	V+			4.5		5.5	V
Power Supply Current	I+	V _{IN} = 0 or V+			0.01	1.0	μA
Power Consumption	P _C						5.5



SPECIFICATIONS (V+ = 3 V)							
Parameter	Symbol	Test Conditions Otherwise Unless Specified V+ = 3 V, ± 10%, VIN = 0.4 or 2.0 V ^e	Temp ^a	Limits -40 to 85°C			Unit
				Min ^b	Typ ^c	Max ^b	
Analog Switch							
Analog Signal Range ^d	V _{NO} , V _{NC} , V _{COM}		Full	0		V+	V
Drain-Source On-Resistance ^d	r _{DS(on)}	V+ = 2.7 V, V _D = 1.5 V, I _S = 10 mA	Room Full		15 19	95 105	Ω
r _{DS(on)} Flatness ^d	r _{DS(on)} Flatness	V _S = 0 to V+, I _S = 10 mA	Room		7.5		
Digital Control							
Input High Voltage	V _{INH}		Full	2			V
Input Low Voltage	V _{INL}		Full			0.8	
Input Current	I _{INL} or I _{INH}	V _{IN} = 0 or V+	Full	-1		1	μA
Dynamic Characteristics							
Turn-On Time ^d	t _{ON}	V _D or V _S = 2.0 V, R _L = 300 Ω, C _L = 35 pF Figure 1 and 2	Room Full		12	45 55	ns
Turn-Off Time ^d	t _{OFF}		Room Full		6	35 40	
Break-Before-Make Time ^d	t _d		Room	1	7		
Charge Injection ^d	Q _{INJ}	C _L = 1 nF, V _{GEN} = 0 V, V _S = 0 V R _{GEN} = 0 Ω, Figure 3	Room		5	10	pC
Power Supply							
Power Supply Range	V+			2.7		3.3	V
Power Supply Current	I+	V _{IN} = 0 or V+			0.01	1.0	μA
Power Consumption	P _C						3.3

SPECIFICATIONS (V+ = 2.5 V)							
Parameter	Symbol	Test Conditions Otherwise Unless Specified V+ = 2.5 V, ±10%, VIN = 0.4 or 2.0 V ^e	Temp ^a	Limits -40 to 85°C			Unit
				Min ^b	Typ ^c	Max ^b	
Analog Switch							
Analog Signal Range ^d	V _{NO} , V _{NC} , V _{COM}		Full	0		V+	V
Drain-Source On-Resistance	r _{DS(on)}	V+ = 2.25 V, V _D = 1.0 V, I _S = 10 mA	Room Full ^d		26 29	110 120	Ω
r _{DS(on)} Flatness ^d	r _{DS(on)} Flatness	V+ = 2.5 V	Room		10		
Digital Control							
Input High Voltage	V _{INH}		Full	2			V
Input Low Voltage	V _{INL}		Full			0.4	
Input Current	I _{INL} or I _{INH}	V _{IN} = 0 or V+	Full	-1		1	μA
Dynamic Characteristics							
Turn-On Time	t _{ON}	V _D or V _S = 1.5 V, R _L = 300 Ω, C _L = 35 pF Figures 1 and 2	Room Full ^d		16	50 60	ns
Turn-Off Time	t _{OFF}		Room Full ^d		7	35 45	
Break-Before-Make Time	t _d		Room	1	12		
Power Supply							
Power Supply Range	V+			2.25		2.75	V
Power Supply Current ^d	I+	V _{IN} = 0 or V+			0.01	1.0	μA
Power Consumption	P _C						2.75

Notes:

- a. Room = 25°C, Full = as determined by the operating suffix.
- b. The algebraic convention whereby the most negative value is a minimum and the most positive a maximum, is used in this data sheet.
- c. Typical values are for design aid only, not guaranteed nor subject to production testing.
- d. Guarantee by design, nor subjected to production test.
- e. V_{IN} = input voltage to perform proper function.
- f. Guaranteed by 5-V leakage testing, not production tested.



TYPICAL CHARACTERISTICS (25°C UNLESS NOTED)

$r_{DS(on)}$ vs. Analog and Power Voltage

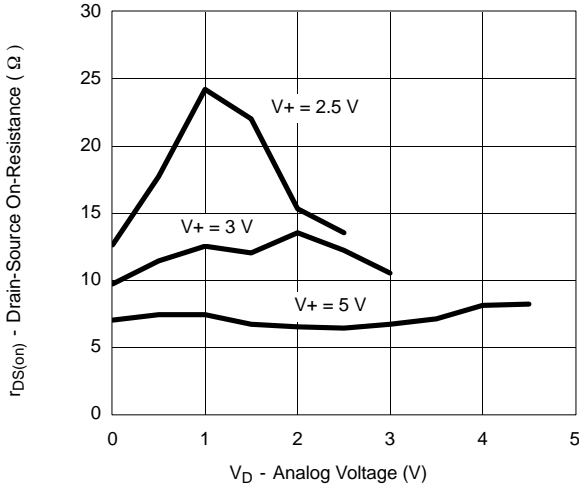

$r_{DS(on)}$ vs. Analog Voltage and Temperature

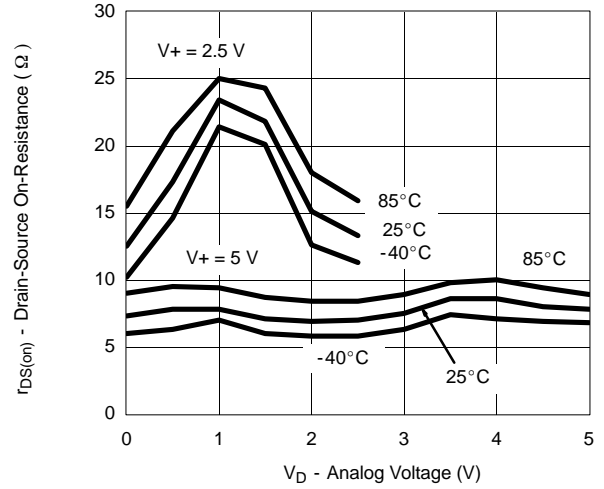

Supply Current vs. Temperature

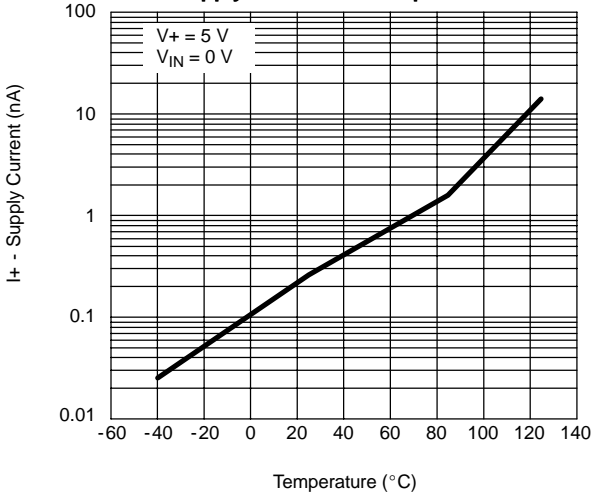

Supply Current vs. Input Switching Frequency

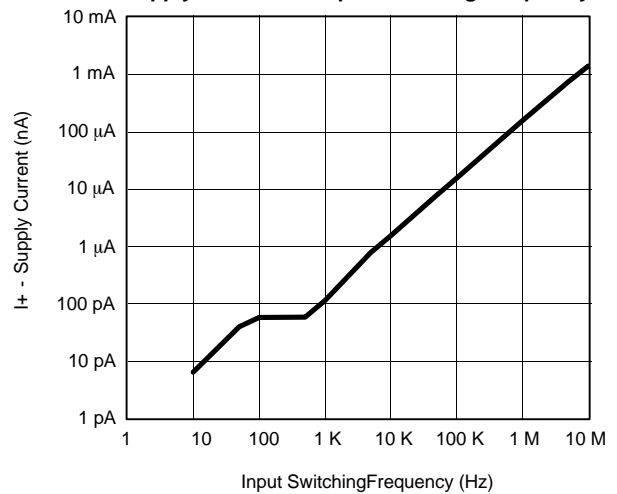

Leakage Current vs. Temperature

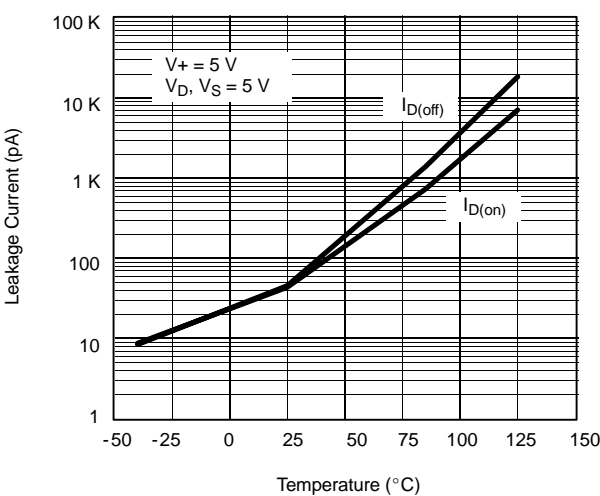

Leakage vs. Analog Voltage

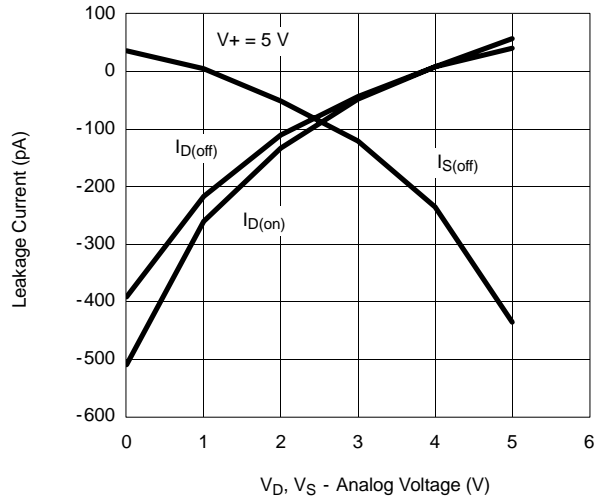



TYPICAL CHARACTERISTICS (25°C UNLESS NOTED)

Switching Time vs. Temperature and Supply Voltage

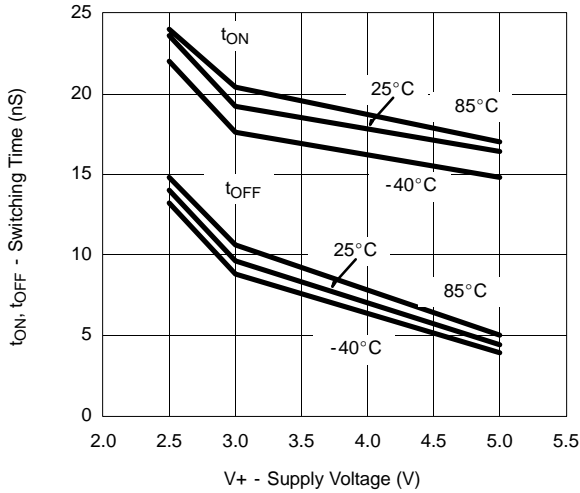

Crosstalk and Off Isolation vs. Frequency

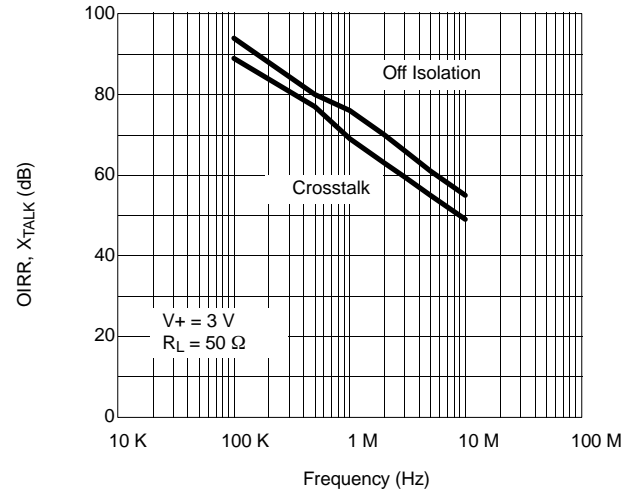

Input Switching Threshold vs. Supply Voltage

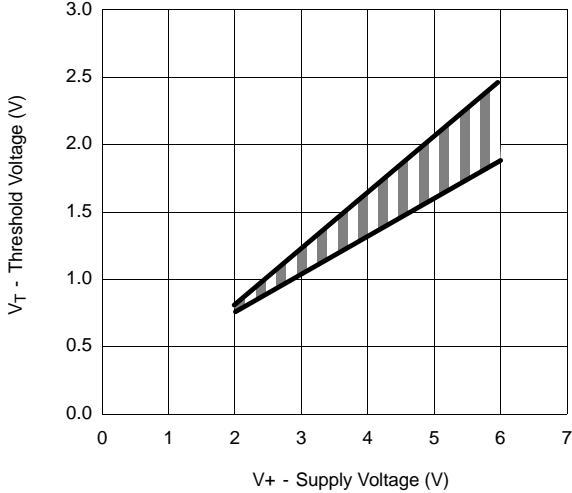

Insertion Loss vs. Frequency

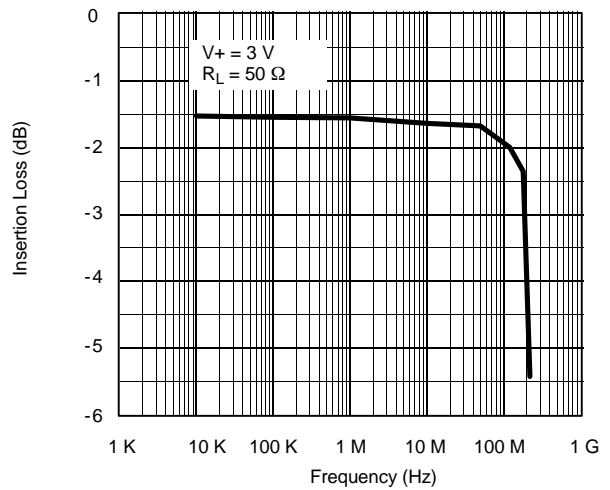

Charge Injection vs. Analog Voltage

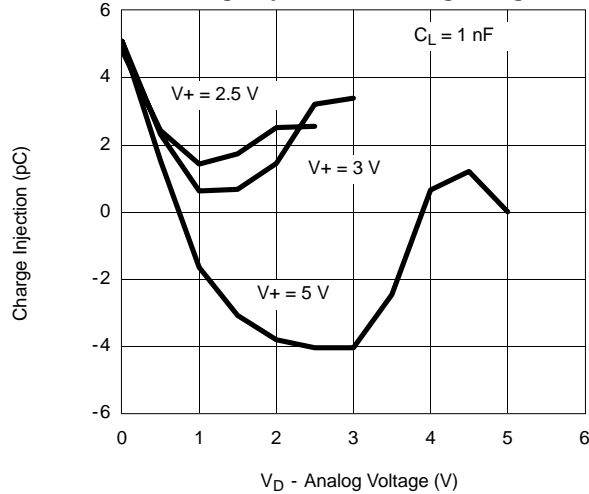

TEST CIRCUITS

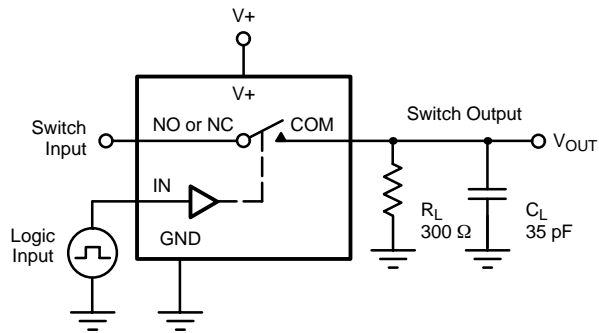

C_L (includes fixture and stray capacitance)

$$V_{OUT} = V_{COM} \left(\frac{R_L}{R_L + R_{ON}} \right)$$

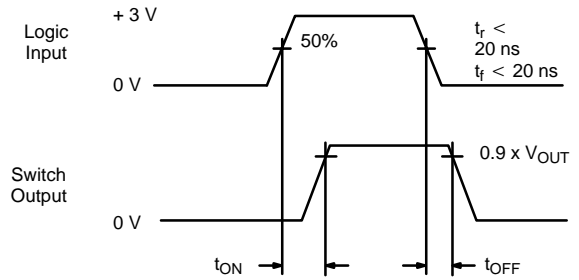

Logic "1" = Switch On
 Logic input waveforms inverted for switches that have the opposite logic sense.

FIGURE 1. Switching Time

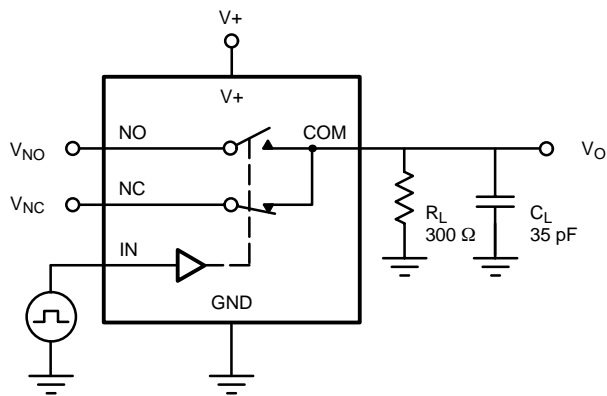

C_L (includes fixture and stray capacitance)

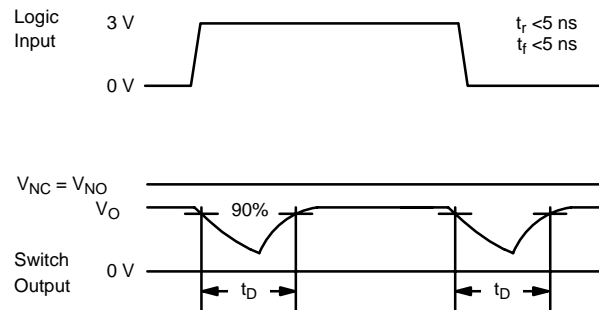
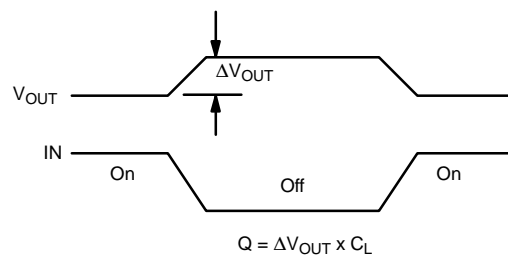
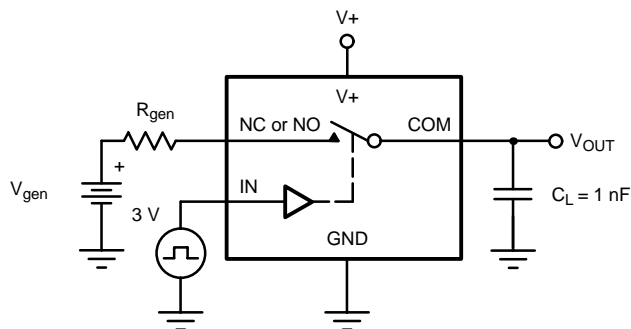

FIGURE 2. Break-Before-Make Interval



IN depends on switch configuration: input polarity determined by sense of switch.

FIGURE 3. Charge Injection

TEST CIRCUITS

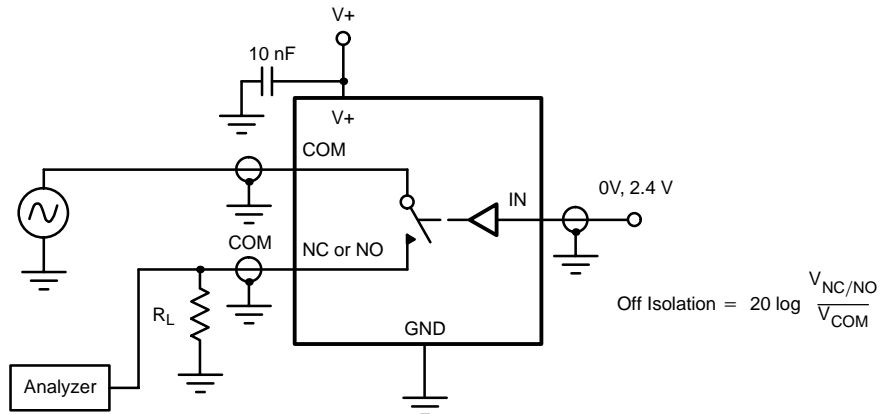

FIGURE 4. Off-Isolation

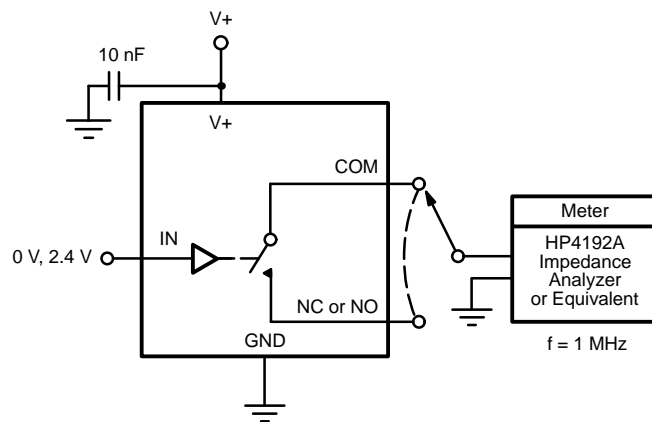

FIGURE 5. Channel Off/On Capacitance