



Precision 8-Ch/Dual 4-Ch Low Voltage Analog Multiplexers

FEATURES

- 2.7-to 12-V Single Supply or ± 3 - to ± 6 -V Dual Supply Operation
- Low On-Resistance— r_{ON} : 3.9 Ω Typ.
- Fast Switching: t_{ON} — 42 ns, t_{OFF} — 24 ns
- Break-Before-Make Guaranteed
- Low Leakage
- TTL, CMOS, LV Logic (3 V) Compatible
- 2000-V ESD Protection (HBM)

BENEFITS

- High Accuracy
- Single and Dual Power Rail Capacity
- Wide Operating Voltage Range
- Simple Logic Interface

APPLICATIONS

- Data Acquisition Systems
- Battery Operated Equipment
- Portable Test Equipment
- Sample and Hold Circuits
- Communication Systems
- SDSL, DSLAM
- Audio and Video Signal Routing

DESCRIPTION

The DG9408/9409 uses BiCMOS wafer fabrication technology that allows the DG9408/9409 to operate on single and dual supplies. Single supply voltage ranges from 3- to 12-V while dual supply operation is recommended with ± 3 to ± 6 V.

The DG9408 is an 8-channel single-ended analog multiplexer designed to connect one of eight inputs to a common output

as determined by a 3-bit binary address (A_0, A_1, A_2). The DG9409 is a dual 4-channel differential analog multiplexer designed to connect one of four differential inputs to a common dual output as determined by its 2-bit binary address (A_0, A_1). Break-before-make switching action to protect against momentary crosstalk between adjacent channels.

FUNCTIONAL BLOCK DIAGRAM AND PIN CONFIGURATION

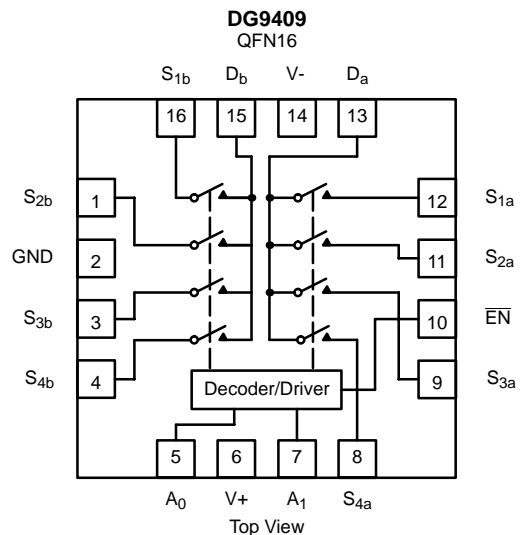
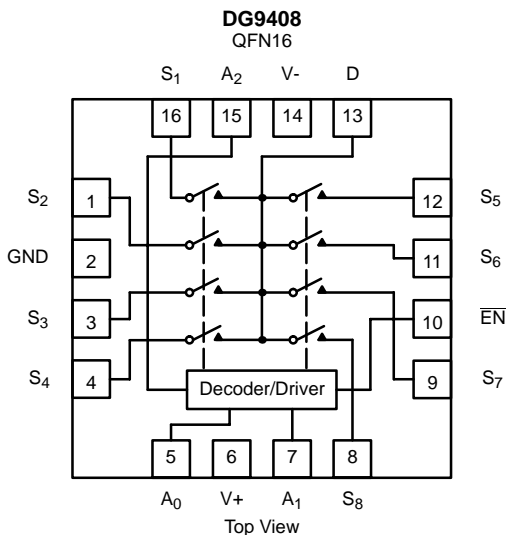



TRUTH TABLES AND ORDERING INFORMATION

TRUTH TABLE — DG9408				
A ₂	A ₁	A ₀	EN	On Switch
X	X	X	1	None
0	0	0	0	1
0	0	1	0	2
0	1	0	0	3
0	1	1	0	4
1	0	0	0	5
1	0	1	0	6
1	1	0	0	7
1	1	1	0	8

TRUTH TABLE — DG9409			
A ₁	A ₀	EN	On Switch
X	X	1	None
0	0	0	1
0	1	0	2
1	0	0	3
1	1	0	4

X = Don't Care

For low and high voltage levels for V_{AX} and V_{EN} consult “Digital Control” Parameters for Specific V+ operation. See Specifications Tables for:

- Single Supply 12 V
- Dual Supply V+ = 5 V, V- = -5 V
- Single Supply 5 V
- Single Supply 3 V

ORDERING INFORMATION — DG9408		
Temp Range	Package	Part Number
-40 to 85°C	16-Pin QFN (4x4 mm)	DG9408DN

ORDERING INFORMATION — DG9409		
Temp Range	Package	Part Number
-40 to 85°C	16-Pin QFN (4x4 mm)	DG9409DN

ABSOLUTE MAXIMUM RATINGS

Voltage Referenced to V-

V+ 14 V

GND 7 V

Digital Inputs^a, V_S, V_D (V-) -0.3 V to (V+) +0.3 V

Current (Any Terminal Except S or D) 30 mA

Continuous Current, S or D) 100 mA

Peak Current, S or D
(Pulsed at 1 ms, 10% Duty Cycle Max) 200 mA

Package Solder Reflow Conditions^d

16-Pin (4x4 mm) QFN 240°C

Storage Temperature -65 to 150°C

Power Dissipation (Package)^b, (T_A = 70°C)

16-Pin (4x4 mm) QFN^c 1880 mW

- Notes
- a. Signals on S_X, D_X or I_{NX} exceeding V+ or V- will be clamped by internal diodes. Limit forward diode current to maximum current ratings.
 - b. All leads soldered or welded to PC board.
 - c. Derate 23.5 mW/°C above 70°C.
 - d. Manual soldering with soldering iron is not recommended for leadless components. The QFN is a leadless package. The end of the lead terminal is exposed copper (not plated) as a result of the singulation process in manufacturing. A solder fillet at the exposed copper lip cannot be guaranteed and is not required to ensure adequate bottom side solder interconnection.



SPECIFICATIONS (SINGLE SUPPLY 12 V)							
Parameter	Symbol	Test Conditions Unless Otherwise Specified $V_+ = 12 V, \pm 10\%, V_- = 0 V$ $V_A, \overline{V_{EN}} = 0.8 V \text{ or } 2.4 V^f$	Temp ^b	Limits -40 to 85°C			Unit
				Min ^c	Typ ^d	Max ^c	
Analog Switch							
Analog Signal Range ^e	V_{ANALOG}		Full	0		12	V
On-Resistance	r_{ON}	$V_+ = 10.8 V, V_D = 2 V \text{ or } 9 V, I_S = 50 \text{ mA}$ Sequence Each Switch On	Room Full		4	7 7.5	Ω
r_{ON} Match Between Channels ^g	Δr_{ON}		Room			3.6	
On-Resistance Flatness ⁱ	r_{ON} Flatness	$V_+ = 10.8 V, V_D = 2 V \text{ or } 9 V, I_S = 50 \text{ mA}$	Room			8	
Switch Off Leakage Current	$I_{S(off)}$	$\overline{V_{EN}} = 2.4 V, V_D = 11 V \text{ or } 1 V, V_S = 1 V \text{ or } 11 V$	Room Full	-2 -15		2 15	nA
	$I_{D(off)}$		Room Full	-2 -15		2 15	
Channel On Leakage Current	$I_{D(on)}$	$\overline{V_{EN}} = 0 V, V_S = V_D = 1 V \text{ or } 11 V$	Room Full	-2 -15		2 15	
Digital Control							
Logic High Input Voltage	V_{INH}		Full	2.4			V
Logic Low Input Voltage	V_{INL}		Full			0.8	
Input Current	I_{IN}	$V_{AX} = \overline{V_{EN}} = 2.4 V \text{ or } 0.8 V$	Full	-1		1	μA
Dynamic Characteristics							
Transition Time	t_{TRANS}	$V_{S1} = 8 V, V_{S8} = 0 V, (DG9408)$ $V_{S1b} = 8 V, V_{S4b} = 0 V, (DG9409)$ See Figure 2	Room Full		42	71 75	ns
Break-Before-Make Time	t_{BBM}	$V_{S(all)} = V_{DA} = 5 V$ See Figure 4	Room Full	2	24		
Enable Turn-On Time	$t_{ON(EN)}$	$V_{AX} = 0 V, V_{S1} = 5 V (DG9408)$ $V_{AX} = 0 V, V_{S1b} = 5 V (DG9409)$ See Figure 3	Room Full		42	70 75	
Enable Turn-Off Time	$t_{OFF(EN)}$		Room Full		24	44 46	
Charge Injection ^e	Q	$C_L = 1 \text{ nF}, V_{GEN} = 0 V, R_{GEN} = 0 \Omega$	Room		29		pC
Off Isolation ^{e, h}	OIRR	$f = 100 \text{ kHz}, R_L = 1 \text{ k}\Omega$	Room		-80		dB
Crosstalk ^e	X_{TALK}		Room		-85		
Source Off Capacitance ^e	$C_{S(off)}$	$f = 1 \text{ MHz}, V_S = 0 V, \overline{V_{EN}} = 2.4 V$	DG9408	Room		21	pF
			DG9409	Room		23	
Drain Off Capacitance ^e	$C_{D(off)}$	$f = 1 \text{ MHz}, V_D = 0 V, \overline{V_{EN}} = 2.4 V$	DG9408	Room		211	
			DG9409	Room		112	
Drain On Capacitance ^e	$C_{D(on)}$	$f = 1 \text{ MHz}, V_D = 0 V, \overline{V_{EN}} = 0 V$	DG9408	Room		238	
			DG9409	Room		137	
Power Supplies							
Power Supply Current	I+	$\overline{V_{EN}} = V_A = 0 V \text{ or } V_+$	Room			1.0	μA



SPECIFICATIONS (DUAL SUPPLY V+ = 5 V, V- = -5 V)							
Parameter	Symbol	Test Conditions Unless Otherwise Specified V+ = 5 V, V- = -5 V ±10% VA, VEN = 0.8 V or 2.0 V ^f	Temp ^b	Limits -40 to 85°C			Unit
				Min ^c	Typ ^d	Max ^c	
Analog Switch							
Analog Signal Range ^e	V _{ANALOG}		Full	-5		5	V
On-Resistance	r _{ON}	V+ = 4.5 V, V- = -4.5 V, V _D = ±3.5 V, I _S = 50 mA Sequence Each Switch On	Room Full		5	8 8.5	Ω
r _{ON} Match Between Channels ^g	Δr _{ON}	V+ = 4.5 V, V- = -4.5 V, V _D = ±3.5 V, I _S = 50 mA	Room			3.6	
On-Resistance Flatness ⁱ	r _{ON} Flatness		Room				
Switch Off Leakage Current ^a	I _{S(off)}	V+ = 5.5 V, V- = -5.5 V V _{EN} = 2.4 V, V _D = ±4.5 V, V _S = ∓4.5 V	Room Full	-2 -15		2 15	nA
	I _{D(off)}		Room Full	-2 -15		2 15	
Channel On Leakage Current ^a	I _{D(on)}	V+ = 5.5 V, V- = -5.5 V V _{EN} = 0 V, V _D = ±4.5 V, V _S = ∓4.5 V	Room Full	-2 -15		2 15	
Digital Control							
Logic High Input Voltage	V _{INH}		Full	2.0			V
Logic Low Input Voltage	V _{INL}		Full			0.8	
Input Current ^a	I _{IN}	V _{AX} = V _{EN} = 2.0 V or 0.8 V	Full	-1		1	μA
Dynamic Characteristics							
Transition Time ^e	t _{TRANS}	V _{S1} = 3.5 V, V _{S8} = -3.5 V, (DG9408) V _{S1b} = 3.5 V, V _{S4b} = -3.5 V, (DG9409) See Figure 2	Room Full		68	89 94	ns
Break-Before-Make Time ^e	t _{BBM}	V _{S(all)} = V _{DA} = 3.5 V See Figure 4	Room Full	1	16		
Enable Turn-On Time ^e	t _{ON(EN)}	V _{AX} = 0 V, V _{S1} = 3.5 V (DG9408) V _{AX} = 0 V, V _{S1b} = 3.5 V (DG9409) See Figure 3	Room Full		68	88 94	
Enable Turn-Off Time ^e	t _{OFF(EN)}		Room Full		58	78 81	
Source Off Capacitance ^e	C _{S(off)}	f = 1 MHz, V _S = 0 V, V _{EN} = 2.0 V	DG9408	Room		23	pF
			DG9409	Room		23	
Drain Off Capacitance ^e	C _{D(off)}	f = 1 MHz, V _D = 0 V, V _{EN} = 2.0 V	DG9408	Room		223	
			DG9409	Room		113	
Drain On Capacitance ^e	C _{D(on)}	f = 1 MHz, V _D = 0 V, V _{EN} = 0 V	DG9408	Room		246	
			DG9409	Room		137	
Power Supplies							
Power Supply Current	I+	V _{EN} = V _A = 0 V or V+	Room			1.0	μA
	I-		Room	-1.0			



SPECIFICATIONS (SINGLE SUPPLY 5 V)								
Parameter	Symbol	Test Conditions Unless Otherwise Specified $V_+ = 5\text{ V}, \pm 10\%, V_- = 0\text{ V}$ $V_A, \overline{V_{EN}} = 0.8\text{ V or }2.0\text{ V}^f$	Temp ^b	Limits -40 to 85°C			Unit	
				Min ^c	Typ ^d	Max ^e		
Analog Switch								
Analog Signal Range ^e	V_{ANALOG}		Full	0		5	V	
On-Resistance	r_{ON}	$V_+ = 4.5\text{ V}, V_D \text{ or } V_S = 1\text{ V or }3.5\text{ V}, I_S = 50\text{ mA}$	Room Full		7	10.5 11	Ω	
r_{ON} Match Between Channels ^g	Δr_{ON}	$V_+ = 4.5\text{ V}, V_D = 1\text{ V or }3.5\text{ V}, I_S = 50\text{ mA}$	Room			3.6		
On-Resistance Flatness ⁱ	r_{ON} Flatness		Room			9		
Switch Off Leakage Current ^a	$I_{S(off)}$	$V_+ = 5.5\text{ V}$ $V_S = 1\text{ V or }4\text{ V}, V_D = 4\text{ V or }1\text{ V}$	Room Full	-2 -15		2 15	nA	
	$I_{D(off)}$		Room Full	-2 -15		2 15		
Channel On Leakage Current ^a	$I_{D(on)}$	$V_+ = 5.5\text{ V}$ $V_D = V_S = 1\text{ V or }4\text{ V}, \text{ Sequence Each Switch On}$	Room Full	-2 -15		2 15		
Digital Control								
Logic High Input Voltage	V_{INH}	$V_+ = 5\text{ V}$	Full	2.0			V	
Logic Low Input Voltage	V_{INL}		Full			0.8		
Input Current ^a	I_{IN}	$V_{AX} = \overline{V_{EN}} = 2.0\text{ V or }0.8\text{ V}$	Full	-1		1	μA	
Dynamic Characteristics								
Transition Time ^e	t_{TRANS}	$V_{S1} = 3.5\text{ V}, V_{S8} = 0\text{ V}, \text{ (DG9408)}$ $V_{S1b} = 3.5\text{ V}, V_{S4b} = 0\text{ V}, \text{ (DG9409)}$ See Figure 2	Room Full		73	94 104	ns	
Break-Before-Make Time ^e	t_{OPEN}	$V_{S(all)} = V_{DA} = 3.5\text{ V}$ See Figure 4	Room Full	2	29			
Enable Turn-On Time ^e	$t_{ON(\overline{EN})}$	$V_{AX} = 0\text{ V}, V_{S1} = 3.5\text{ V} \text{ (DG9408)}$ $V_{AX} = 0\text{ V}, V_{S1b} = 3.5\text{ V} \text{ (DG9409)}$ See Figure 3	Room Full		74	94 104		
Enable Turn-Off Time ^e	$t_{OFF(\overline{EN})}$		Room Full		38	57 61		
Charge Injection ^e	Q	$C_L = 1\text{ nF}, R_{GEN} = 0\ \Omega, V_{GEN} = 0\text{ V}$	Room		20		pC	
Off Isolation ^{e, h}	OIRR	$R_L = 1\text{ k}\Omega, f = 100\text{ kHz}$	Room		-81		dB	
Crosstalk ^e	X_{TALK}		Room		-85			
Source Off Capacitance ^e	$C_{S(off)}$	$f = 1\text{ MHz}, V_S = 0\text{ V}, \overline{V_{EN}} = 0\text{ V}$	DG9408	Room		22	pF	
			DG9409	Room		24		
Drain Off Capacitance ^e	$C_{D(off)}$	$f = 1\text{ MHz}, V_D = 0\text{ V}, \overline{V_{EN}} = 2.0\text{ V}$	DG9408	Room		223		
			DG9409	Room		113		
Drain On Capacitance ^e	$C_{D(on)}$	$f = 1\text{ MHz}, V_D = 0\text{ V}, \overline{V_{EN}} = 0\text{ V}$	DG9408	Room		244		
			DG9409	Room		143		
Power Supplies								
Power Supply Current	I+	$\overline{V_{EN}} = V_A = 0\text{ V or }V_+$	Room			1.0		μA



SPECIFICATIONS (SINGLE SUPPLY 3 V)							
Parameter	Symbol	Test Conditions Unless Otherwise Specified $V_+ = 3\text{ V}, \pm 10\%, V_- = 0\text{ V}$ $\overline{V_{EN}} = 0.4\text{ V or }1.8\text{ V}^f$	Temp ^b	Limits -40 to 85°C			Unit
				Min ^c	Typ ^d	Max ^c	
Analog Switch							
Analog Signal Range ^e	V_{ANALOG}		Full	0		3	V
On-Resistance	r_{ON}	$V_+ = 2.7\text{ V}, V_D = 0.5\text{ or }2.2\text{ V}, I_S = 5\text{ mA}$	Room Full		12	25.5 26.5	Ω
r_{ON} Match Between Channels ^g	Δr_{ON}	$V_+ = \pm 2.7\text{ V}, V_D = 0.5\text{ V or }2.2\text{ V}, I_S = 5\text{ mA}$	Room			3.6	
On-Resistance Flatness ⁱ	r_{ON} Flatness		Room			13	
Switch Off Leakage Current ^a	$I_{S(off)}$	$V_+ = 3.3\text{ V}$ $V_S = 2\text{ or }1\text{ V}, V_D = 1\text{ or }2\text{ V}$	Room Full	-2 -15		2 15	nA
	$I_{D(off)}$		Room Full	-2 -15		2 15	
Channel On Leakage Current ^a	$I_{D(on)}$	$V_+ = 3.3\text{ V}$ $V_D = V_S = 1\text{ or }2\text{ V}, \text{ Sequence Each Switch On}$	Room Full	-2 -15		2 15	
Digital Control							
Logic High Input Voltage	V_{INH}		Full	1.8			V
Logic Low Input Voltage	V_{INL}		Full			0.4	
Input Current ^a	I_{IN}	$V_{AX} = \overline{V_{EN}} = 1.8\text{ V or }0.4\text{ V}$	Full	-1		1	μA
Dynamic Characteristics							
Transition Time	t_{TRANS}	$V_{S1} = 1.5\text{ V}, V_{S8} = 0\text{ V}, \text{ (DG9408)}$ $V_{S1b} = 1.5\text{ V}, V_{S4b} = 0\text{ V}, \text{ (DG9409)}$ See Figure 2	Room Full		140	165 182	ns
Break-Before-Make Time	t_{BBM}	$V_{S(all)} = V_{DA} = 1.5\text{ V}$ See Figure 4	Room Full	2	63		
Enable Turn-On Time	$t_{ON(\overline{EN})}$	$V_{AX} = 0\text{ V}, V_{S1} = 1.5\text{ V} \text{ (DG9408)}$ $V_{AX} = 0\text{ V}, V_{S1b} = 1.5\text{ V} \text{ (DG9409)}$ See Figure 3	Room Full		140	162 178	
Enable Turn-Off Time	$t_{OFF(\overline{EN})}$		Room Full		76	97 104	
Charge Injection ^e	Q	$C_L = 1\text{ nF}, R_{GEN} = 0\ \Omega, V_{GEN} = 0\text{ V}$	Room		7		pC
Off Isolation ^{e, h}	OIRR	$f = 100\text{ kHz}, R_L = 1\text{ k}\Omega$	Room		-81		dB
Crosstalk ^e	X_{TALK}		Room		-85		
Source Off Capacitance ^e	$C_{S(off)}$	$f = 1\text{ MHz}, V_S = 0\text{ V}, \overline{V_{EN}} = 1.8\text{ V}$	DG9408	Room		23	pF
			DG9409	Room		25	
Drain Off Capacitance ^e	$C_{D(off)}$	$f = 1\text{ MHz}, V_D = 0\text{ V}, \overline{V_{EN}} = 1.8\text{ V}$	DG9408	Room		230	
			DG9409	Room		120	
Drain On Capacitance ^e	$C_{D(on)}$	$f = 1\text{ MHz}, V_D = 0\text{ V}, \overline{V_{EN}} = 0\text{ V}$	DG9408	Room		256	
			DG9409	Room		147	
Power Supplies							
Power Supply Current	I+	$\overline{V_{EN}} = V_A = 0\text{ V or }V_+$	Room			1.0	μA

Notes

- Leakage parameters are guaranteed by worst case test condition and not subject to production test.
- Room = 25°C, Full = as determined by the operating temperature suffix.
- The algebraic convention whereby the most negative value is a minimum and the most positive a maximum, is used in this data sheet.
- Typical values are for DESIGN AID ONLY, not guaranteed nor subject to production testing.
- Guaranteed by design, not subject to production test.
- V_{IN} = input voltage to perform proper function.
- $\Delta r_{DON} = r_{DON\text{ Max}} - r_{DON\text{ Min}}$.
- Worst case isolation occurs on Channel 4 do to proximity to the drain pin.
- r_{DON} flatness is measured as the difference between the minimum and maximum measured values across a defined Analog signal.

TYPICAL CHARACTERISTICS (25°C UNLESS NOTED)

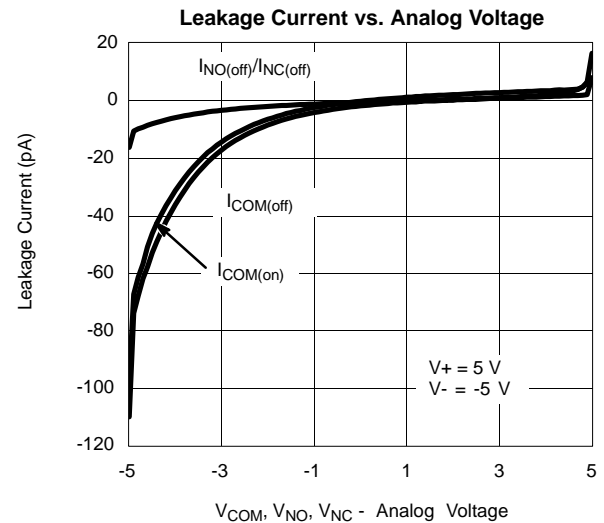
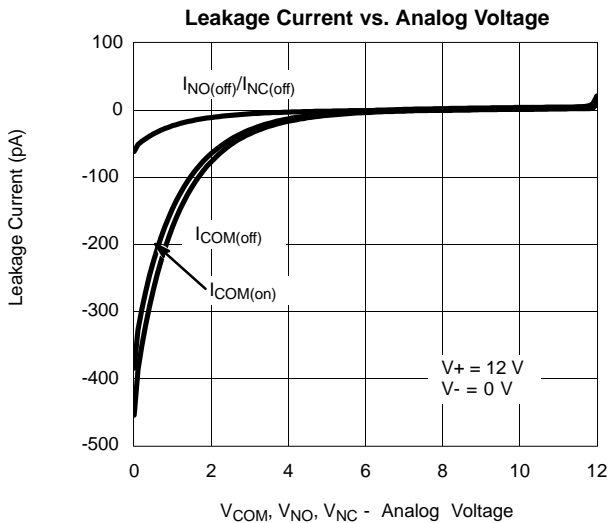
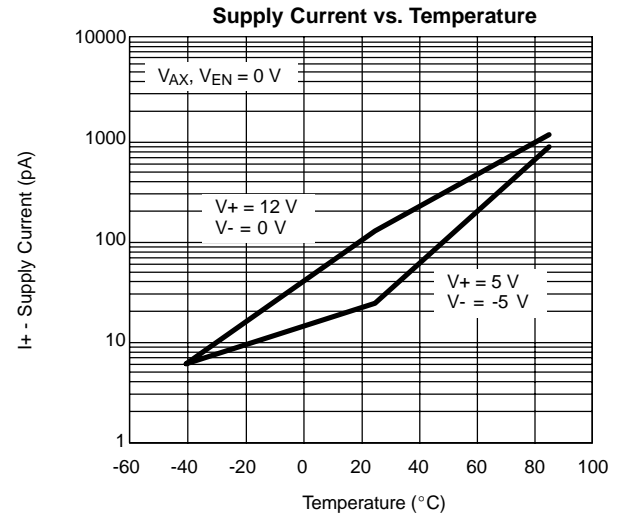
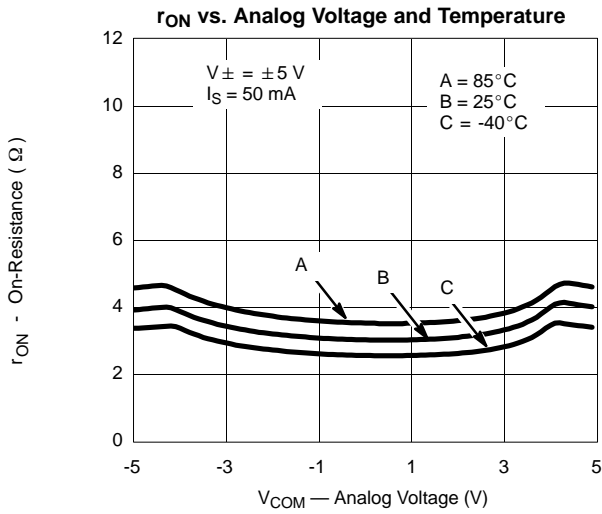
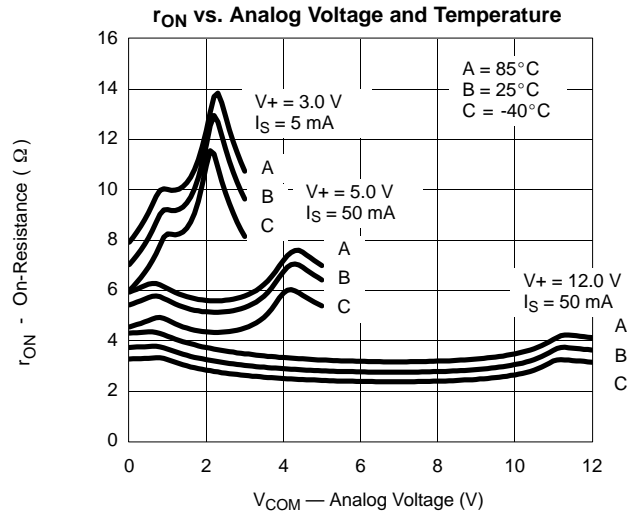
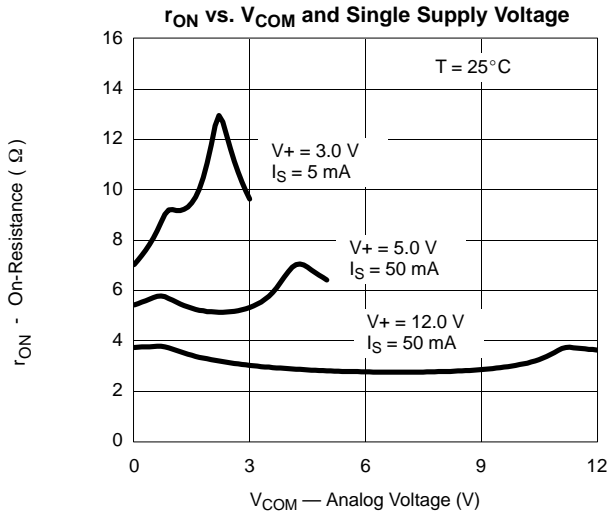



TYPICAL CHARACTERISTICS (25°C UNLESS NOTED)

Switching Time vs. Temperature and Single Supply Voltage

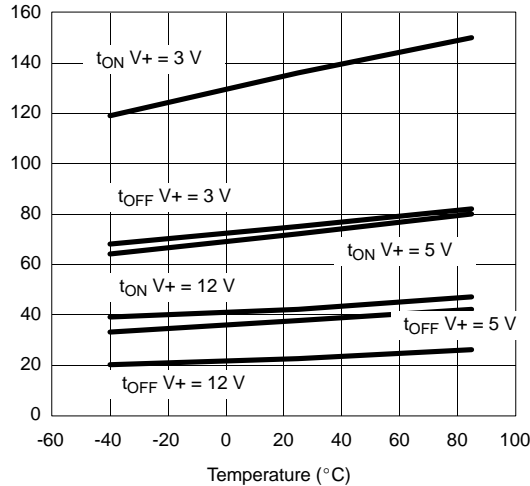

Transition Time vs. Temperature and Single Supply Voltage

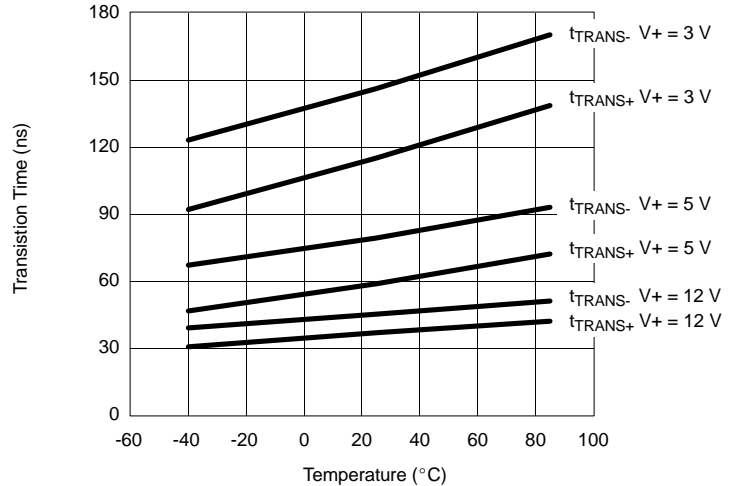

Leakage Current vs. Temperature

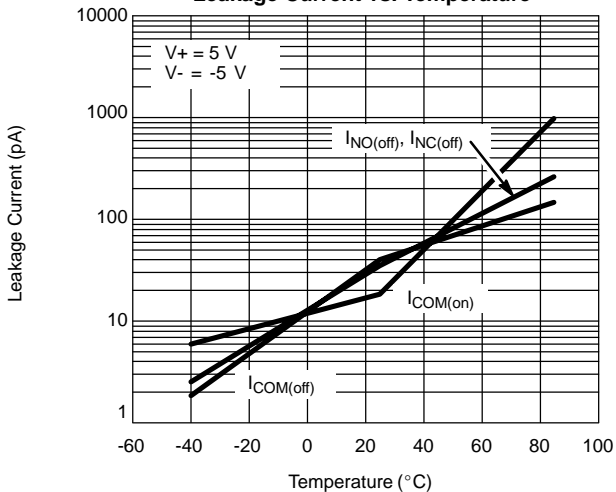

Switching Threshold vs. Supply Voltage

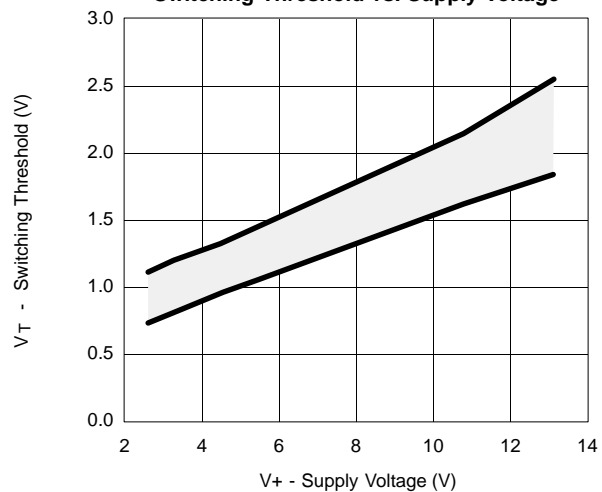

Insertion Loss, Off Isolation and Crosstalk vs. Frequency (DG9408)

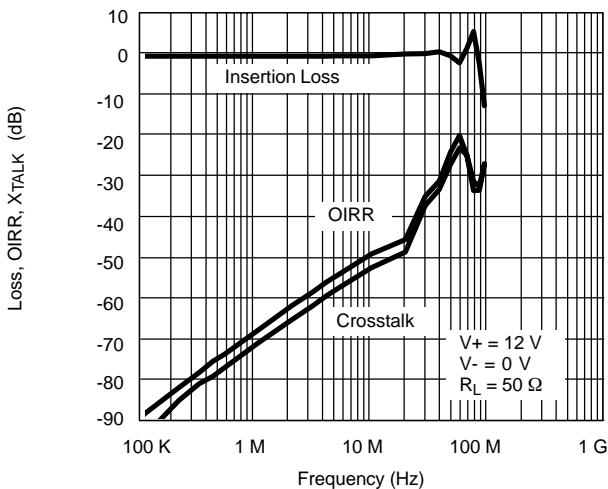

Insertion Loss, Off Isolation and Crosstalk vs. Frequency (DG9404)

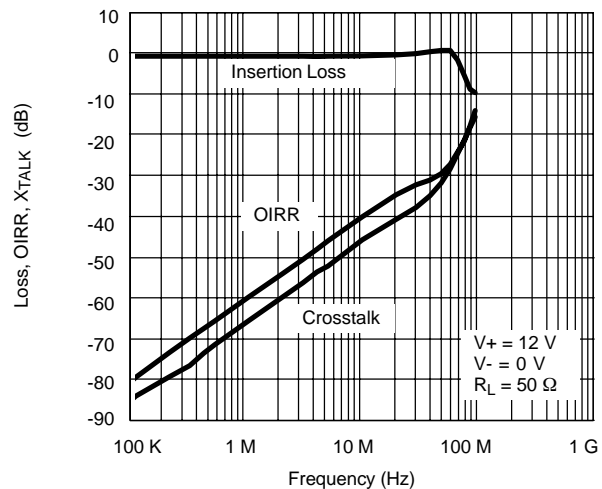

TYPICAL CHARACTERISTICS (25°C UNLESS NOTED)

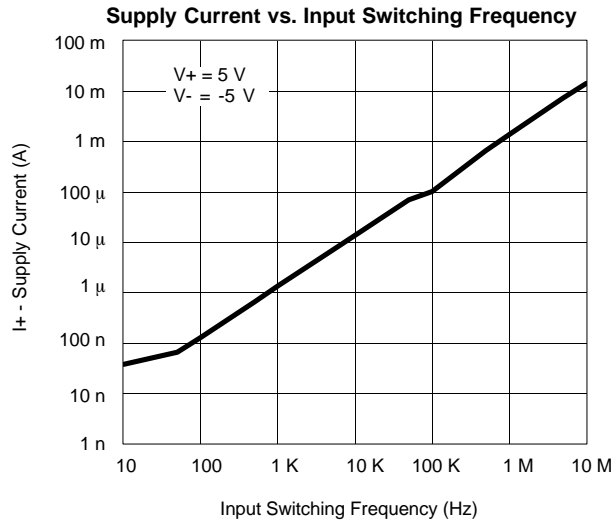

SCHEMATIC DIAGRAM (TYPICAL CHANNEL)

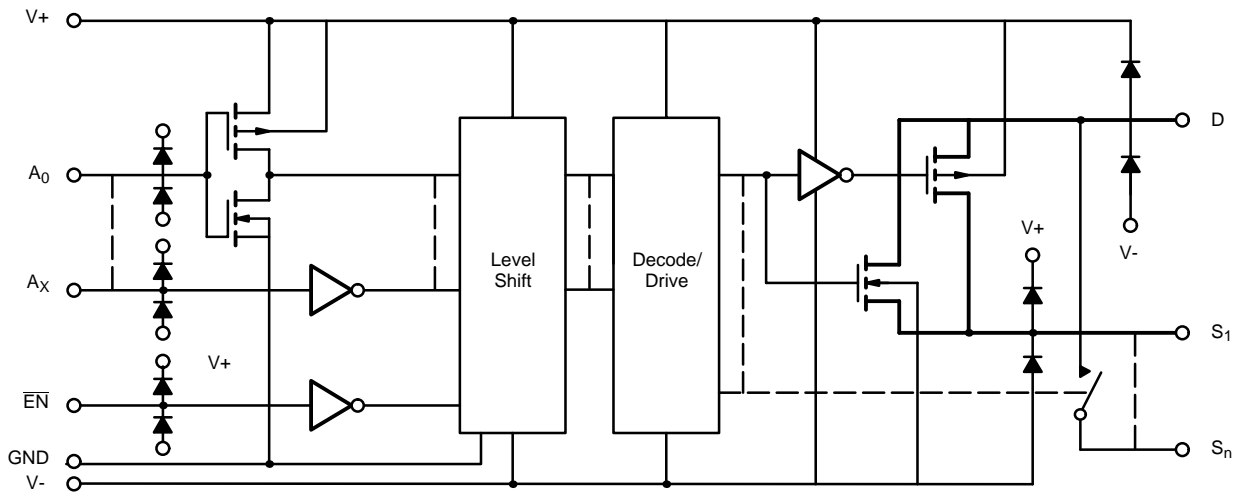
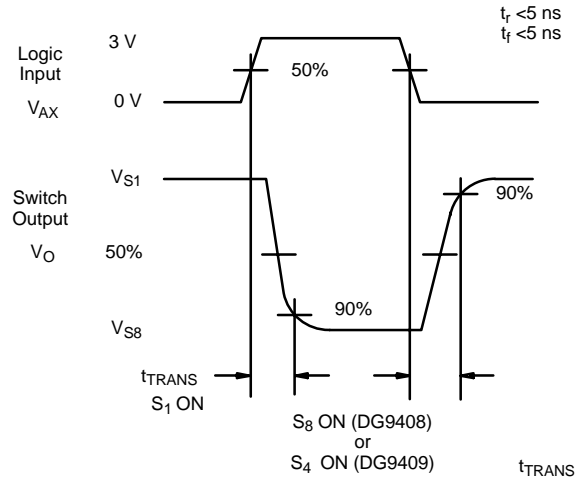
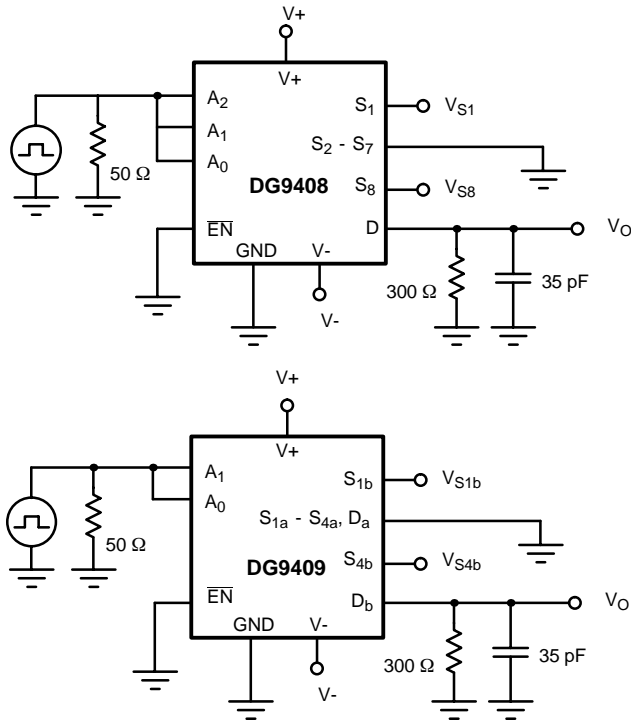

FIGURE 1.

TEST CIRCUITS



Return to Specifications:
 Single Supply 12 V
 Dual Supply V+ = 5 V, V- = -5 V
 Single Supply 5 V
 Single Supply 3 V

FIGURE 2. Transition Time

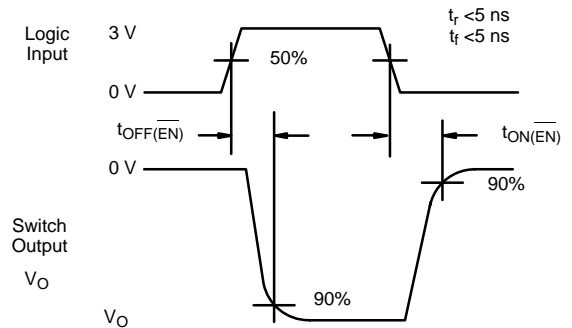
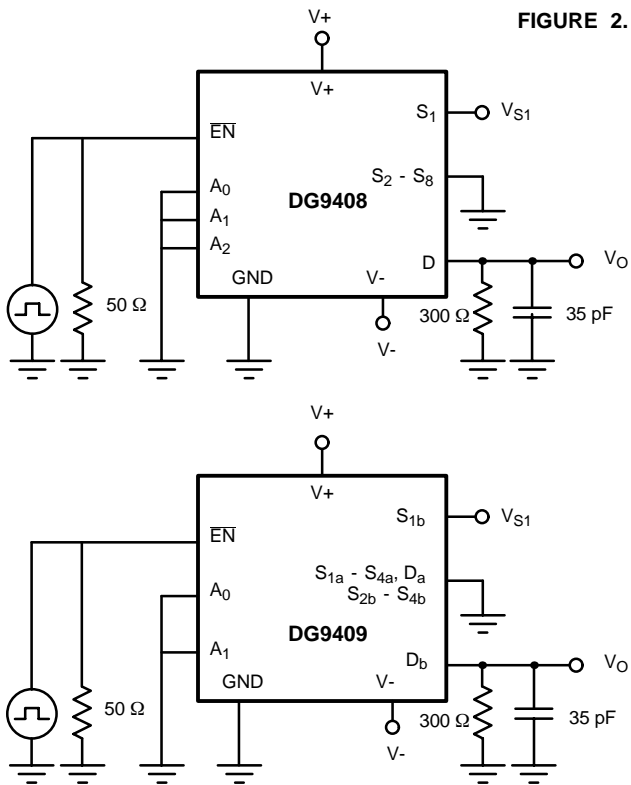

Return to Specifications:
 Single Supply 12 V
 Dual Supply V+ = 5 V, V- = -5 V
 Single Supply 5 V
 Single Supply 3 V

FIGURE 3. Enable Switching Time

TEST CIRCUITS

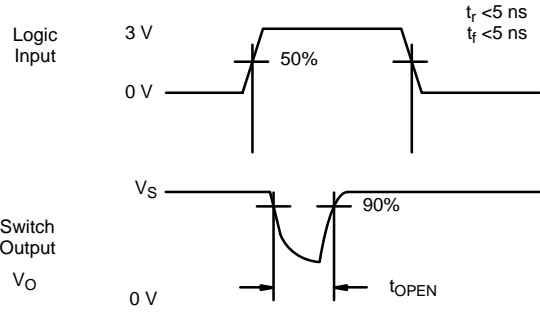
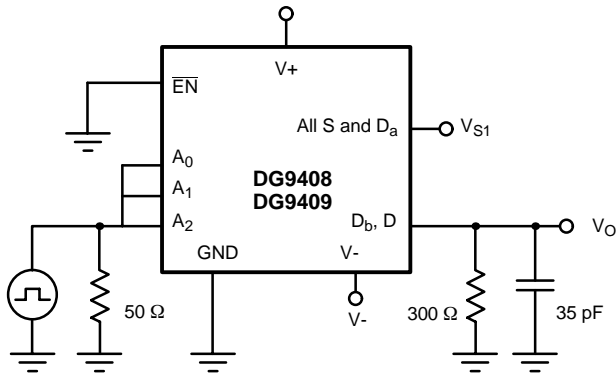
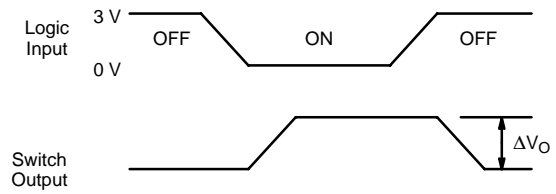
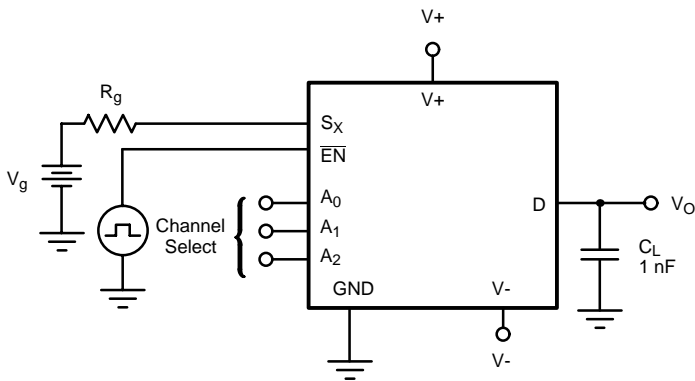

FIGURE 4. Break-Before-Make Interval

Return to Specifications:
[Single Supply 12 V](#)
[Dual Supply V+ = 5 V, V- = -5 V](#)
[Single Supply 5 V](#)
[Single Supply 3 V](#)



ΔV_O is the measured voltage due to charge transfer error Q , when the channel turns off.

$$Q = C_L \times \Delta V_O$$

FIGURE 5. Charge Injection

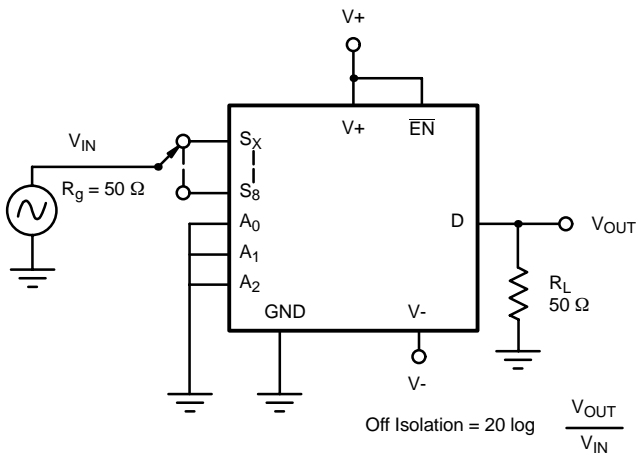

$$\text{Off Isolation} = 20 \log \frac{V_{OUT}}{V_{IN}}$$

FIGURE 6. Off Isolation

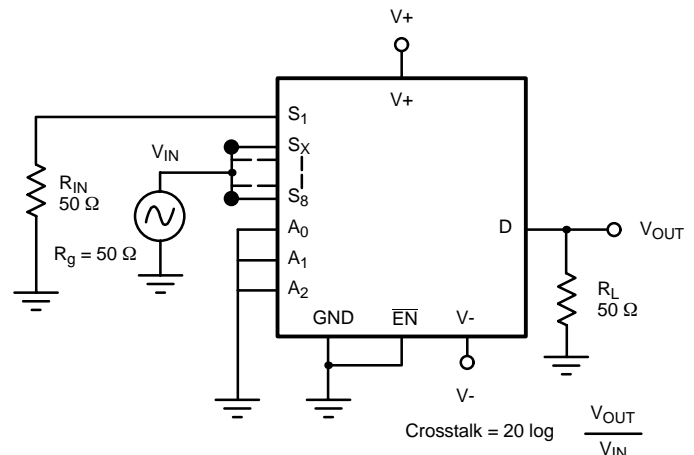

$$\text{Crosstalk} = 20 \log \frac{V_{OUT}}{V_{IN}}$$

FIGURE 7. Crosstalk

TEST CIRCUITS

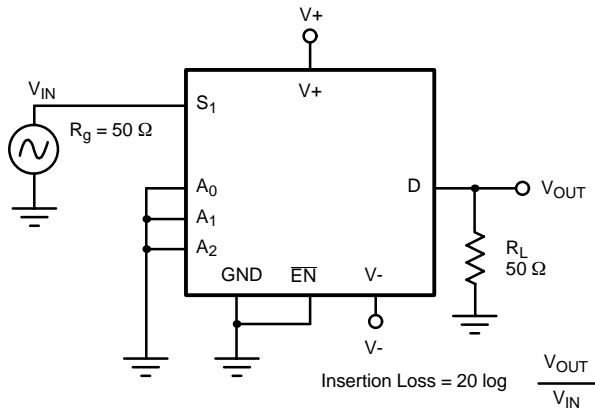

FIGURE 8. Insertion Loss

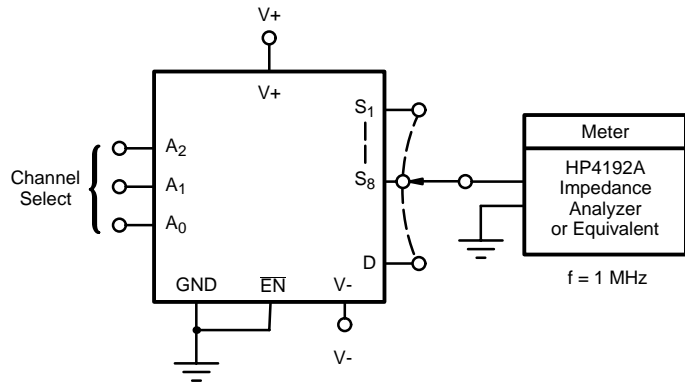

FIGURE 9. Source Drain Capacitance