

## Zener Diodes

### Features

- Silicon Planar Power Zener Diodes.
- Low profile surface-mount package.
- Low leakage current
- High temperature soldering:  
260 °C/10 sec. at terminals

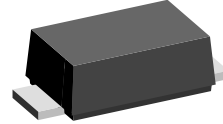

17249

### Mechanical Data

**Case:** JEDEC DO-219AB (SMF) Plastic Case

**Packaging codes/options:**

G1/10 K per 13 " reel, (8 mm tape), 50 K/box

G2/3 K per 7 " reel, (8 mm tape), 30 K/box

**Weight:** approx. 0.01 g

### Absolute Maximum Ratings

$T_{amb} = 25\text{ °C}$ , unless otherwise specified

Parameter	Test condition	Symbol	Value	Unit
Zener current (see Table "Characteristics")			see page 2	
Power dissipation	$T_A = 25\text{ °C}$	$P_{tot}$	800 <sup>1)</sup>	mW

1) Mounted on epoxy glass PCB with 3 x 3 mm, Cu pads ( $\geq 40\text{ }\mu\text{m}$  thick)

### Maximum Thermal Resistance

$T_{amb} = 25\text{ °C}$ , unless otherwise specified

Parameter	Symbol	Value	Unit
Thermal resistance junction to ambient air <sup>1)</sup>	$R_{\theta JA}$	180	K/W
Maximum junction temperature	$T_j$	150	°C
Storage temperature range	$T_{STG}$	- 55 to + 150	°C

1) Mounted on epoxy glass PCB with 3 x 3 mm, Cu pads ( $\geq 40\text{ }\mu\text{m}$  thick)

# GZF3V6C to GZF91C



Vishay Semiconductors

## Electrical Characteristics

Maximum  $V_F = 1.2\text{ V}$  at  $I_F = 200\text{ mA}$

Partnumber	Marking Code	Zener Voltage Range <sup>1)</sup>		Differential Resistance		Temperature Coefficient		Test Current	Reverse Current at Reverse Voltage		
		$V_Z @ I_{ZT}$		$r_{dif} @ I_Z$		$\alpha_Z @ I_Z$			$I_{ZT}$	$I_R$	$V_R$
		V		$\Omega$		%/°C			mA	$\mu\text{A}$	V
		min	max	typ	max	min	max		max		
GZF3V6C	W5	3.4	3.8	4	8	-0.14	-0.04	100	100	1	
GZF3V9C	W6	3.7	4.1	4	8	-0.14	-0.04	100	50	1	
GZF4V3C	W7	4	4.6	4	7	-0.12	-0.02	100	25	1	
GZF4V7C	W8	4.4	5	3	7	-0.1	0	100	10	1	
GZF5V1C	W9	4.8	5.4	3	6	-0.08	-0.2	100	5	1	
GZF5V6C	WA	5.2	6	2	4	-0.04	0.04	100	10	2	
GZF6V2C	WB	5.8	6.6	2	3	-0.01	0.06	100	5	2	
GZF6V8C	WC	6.4	7.2	1	3	0	0.07	100	10	3	
GZF7V5C	WD	7	7.9	1	2	0	0.07	100	50	3	
GZF8V2C	WE	7.7	8.7	1	2	0.03	0.08	100	10	3	
GZF9V1C	WF	8.5	9.6	2	4	0.03	0.08	50	10	5	
GZF10C	WG	9.4	10.6	2	4	0.05	0.09	50	7	7.5	
GZF11C	WH	10.4	11.6	4	7	0.05	0.1	50	4	8.2	
GZF12C	WI	11.4	12.7	4	7	0.05	0.1	50	3	9.1	
GZF13C	WK	12.4	14.1	5	10	0.05	0.1	50	2	10	
GZF15C	WL	13.8	15.6	5	10	0.05	0.1	50	1	11	
GZF16C	WM	15.3	17.1	6	15	0.06	0.11	25	1	12	
GZF18C	WN	16.8	19.1	6	15	0.06	0.11	25	1	13	
GZF20C	WO	18.8	21.2	6	15	0.06	0.11	25	1	15	
GZF22C	WP	20.8	23.3	6	15	0.06	0.11	25	1	16	
GZF24C	WR	22.8	25.6	7	15	0.06	0.11	25	1	18	
GZF27C	WS	25.1	28.9	7	15	0.06	0.11	25	1	20	
GZF30C	WT	28	32	8	15	0.06	0.11	25	1	22	
GZF33C	WU	31	35	8	15	0.06	0.11	25	1	24	
GZF36C	WW	34	38	21	40	0.06	0.11	10	1	27	
GZF39C	WX	37	41	21	40	0.06	0.11	10	1	30	
GZF43C	WY	40	46	24	45	0.07	0.12	10	1	33	
GZF47C	WZ	44	50	24	45	0.07	0.12	10	1	36	
GZF51C	X1	48	54	25	60	0.07	0.12	10	1	39	
GZF56C	X2	52	60	25	60	0.07	0.12	10	1	43	
GZF62C	X3	58	66	25	80	0.08	0.13	10	1	47	
GZF68C	X4	64	72	25	80	0.08	0.13	10	1	51	
GZF75C	X5	70	79	30	100	0.08	0.13	10	1	56	
GZF82C	X6	77	87	30	100	0.08	0.13	10	1	62	
GZF91C	X7	85	96	60	200	0.09	0.13	5	1	68	

<sup>1)</sup> Pulse test:  $t_p \leq 5\text{ ms}$

## Typical Characteristics ( $T_{amb} = 25\text{ }^{\circ}\text{C}$ unless otherwise specified)

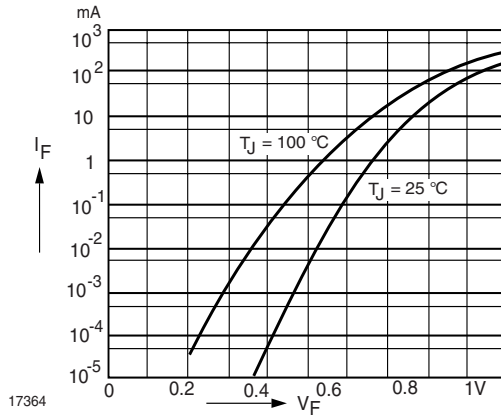

Figure 1. Forward characteristics

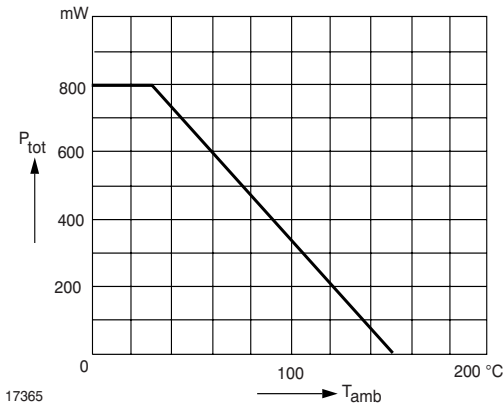

Figure 2. Admissible Power Dissipation vs. Ambient Temperature

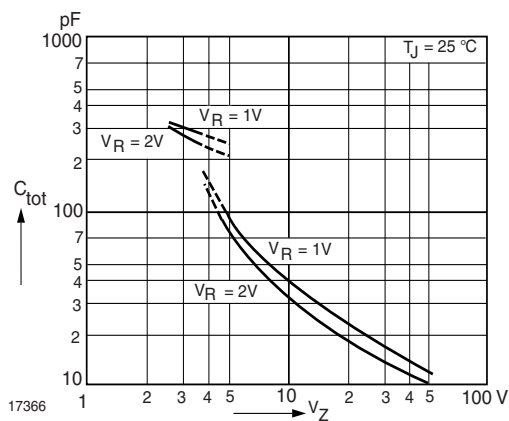

Figure 3. Capacitance vs. Zener Voltage

# GZF3V6C to GZF91C

Vishay Semiconductors



## Package Dimensions in mm

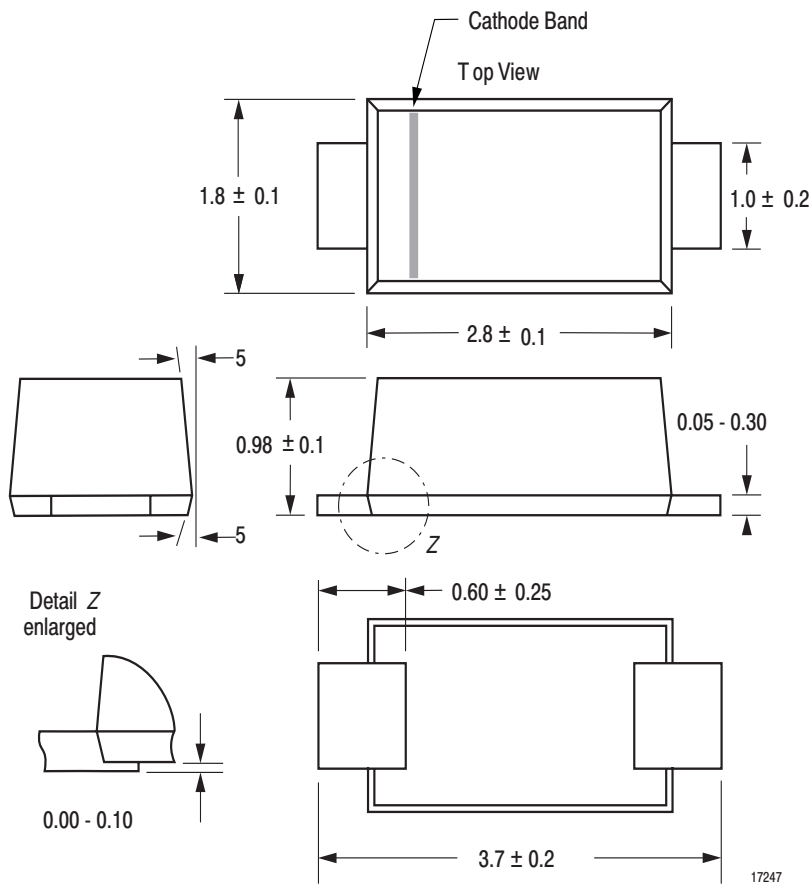

## Mounting Pad Layout

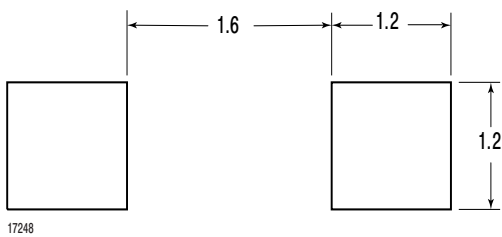



## Ozone Depleting Substances Policy Statement

It is the policy of **Vishay Semiconductor GmbH** to

1. Meet all present and future national and international statutory requirements.
2. Regularly and continuously improve the performance of our products, processes, distribution and operating systems with respect to their impact on the health and safety of our employees and the public, as well as their impact on the environment.

It is particular concern to control or eliminate releases of those substances into the atmosphere which are known as ozone depleting substances (ODSs).

The Montreal Protocol (1987) and its London Amendments (1990) intend to severely restrict the use of ODSs and forbid their use within the next ten years. Various national and international initiatives are pressing for an earlier ban on these substances.

**Vishay Semiconductor GmbH** has been able to use its policy of continuous improvements to eliminate the use of ODSs listed in the following documents.

1. Annex A, B and list of transitional substances of the Montreal Protocol and the London Amendments respectively
2. Class I and II ozone depleting substances in the Clean Air Act Amendments of 1990 by the Environmental Protection Agency (EPA) in the USA
3. Council Decision 88/540/EEC and 91/690/EEC Annex A, B and C (transitional substances) respectively.

**Vishay Semiconductor GmbH** can certify that our semiconductors are not manufactured with ozone depleting substances and do not contain such substances.

**We reserve the right to make changes to improve technical design  
and may do so without further notice.**

Parameters can vary in different applications. All operating parameters must be validated for each customer application by the customer. Should the buyer use Vishay Semiconductors products for any unintended or unauthorized application, the buyer shall indemnify Vishay Semiconductors against all claims, costs, damages, and expenses, arising out of, directly or indirectly, any claim of personal damage, injury or death associated with such unintended or unauthorized use.

Vishay Semiconductor GmbH, P.O.B. 3535, D-74025 Heilbronn, Germany  
Telephone: 49 (0)7131 67 2831, Fax number: 49 (0)7131 67 2423