

High Speed Optocoupler, 1 MBd, Transistor Output

Features

- Isolation Test Voltage: 5300 V_{RMS}
- TTL Compatible
- High Bit Rates: 1.0 Mbit/s
- High Common-mode Interference Immunity
- Bandwidth 2.0 MHz
- Open-collector Output
- External Base Wiring Possible

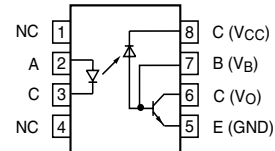
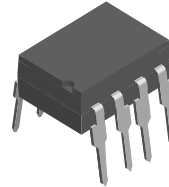

1179081

Agency Approvals

- UL - File No. E52744 System Code H or J
- CSA 93751
- DIN EN 60747-5-2(VDE0884)
DIN EN 60747-5-5 pending
Available with Option 1

Signals can be transmitted between two electrically separated circuits up to frequencies of 2.0 MHz. The potential difference between the circuits to be coupled should not exceed the maximum permissible reference voltages.

Description

The SFH6135 and SFH6136 optocouplers feature a high signal transmission rate and a high isolation resistance. They have a GaAlAs infrared emitting diode, optically coupled with an integrated photo detector which consists of a photo diode and a high-speed transistor in a DIP-8 plastic package.

Order Information

Part	Remarks
SFH6135	CTR ≥ 7.0 %, DIP-8
SFH6136	CTR ≥ 19 %, DIP-8

For additional information on the available options refer to Option Information.

Absolute Maximum Ratings

T_{amb} = 25 °C, unless otherwise specified

Stresses in excess of the absolute Maximum Ratings can cause permanent damage to the device. Functional operation of the device is not implied at these or any other conditions in excess of those given in the operational sections of this document. Exposure to absolute Maximum Rating for extended periods of the time can adversely affect reliability.

Input

Parameter	Test condition	Symbol	Value	Unit
Reverse voltage		V _R	3.0	V
Forward current		I _F	25	mA
Peak forward current	t = 1.0 ms, duty cycle 50 %	I _{FM}	50	mA
Maximum surge forward current	t ≤ 1.0 μs, 300 pulses/s	I _{FSM}	1.0	A
Thermal resistance		R _{thja}	700	K/W
Power dissipation		P _{diss}	45	mW

Output

Parameter	Test condition	Symbol	Value	Unit
Supply voltage		V_S	- 0.5 to 30	V
Output voltage		V_O	- 0.5 to 25	V
Emitter-base voltage		V_{EBO}	5.0	V
Output current		I_O	8.0	mA
Maximum output current		I_O	16	mA
Base current		I_B	5.0	mA
Thermal resistance		R_{thja}	300	K/W
Power dissipation	$T_{amb} = 70\text{ }^\circ\text{C}$	P_{diss}	100	mW

Coupler

Parameter	Test condition	Symbol	Value	Unit
Isolation test voltage		V_{ISO}	5300	V_{RMS}
Pollution degree (DIN VDE 0110)			2	
Creepage			≥ 7.0	mm
Clearance			≥ 7.0	mm
Comparative tracking index per DIN IEC 112/VDE 0303 part 1			175	
Isolation resistance	$V_{IO} = 500\text{ V}, T_{amb} = 25\text{ }^\circ\text{C}$	R_{IO}	$\geq 10^{12}$	Ω
	$V_{IO} = 500\text{ V}, T_{amb} = 100\text{ }^\circ\text{C}$	R_{IO}	$\geq 10^{11}$	Ω
Storage temperature range		T_{stg}	- 55 to + 125	$^\circ\text{C}$
Ambient temperature range		T_{amb}	- 55 to + 100	$^\circ\text{C}$
Soldering temperature	max. $\leq 10\text{ s}$, dip soldering $\geq 0.5\text{ mm}$ distance from case bottom	T_{sld}	260	$^\circ\text{C}$

Electrical Characteristics

$T_{amb} = 25\text{ }^\circ\text{C}$, unless otherwise specified

Minimum and maximum values are testing requirements. Typical values are characteristics of the device and are the result of engineering evaluation. Typical values are for information only and are not part of the testing requirements.

Input

Parameter	Test condition	Symbol	Min	Typ.	Max	Unit
Forward voltage	$I_F = 16\text{ mA}$	V_F		1.6	1.9	V
Breakdown voltage	$I_R = 10\text{ }\mu\text{A}$	V_{BR}	3.0			V
Reverse current	$V_R = 3.0\text{ V}$	I_R		0.5	10	μA
Capacitance	$V_R = 0\text{ V}, f = 1.0\text{ MHz}$	C_O		125		pF
Temperature coefficient of forward voltage	$I_F = 16\text{ mA}$	$\Delta V_F / \Delta T_{amb}$		1.7		mV/ $^\circ\text{C}$

Output

Parameter	Test condition	Part	Symbol	Min	Typ.	Max	Unit
Logic low supply current	$I_F = 16 \text{ mA}$, V_O open, $V_{CC} = 15 \text{ V}$		I_{CCL}		150		μA
Logic high supply current	$I_F = 0 \text{ mA}$, V_O open, $V_{CC} = 15 \text{ V}$		I_{CCH}		0.01	1.0	μA
Output voltage, output low	$I_F = 16 \text{ mA}$, $V_{CC} = 4.5 \text{ V}$, $I_O = 1.1 \text{ mA}$	SFH6135	V_{OL}		0.1	0.4	V
	$I_F = 16 \text{ mA}$, $V_{CC} = 4.5 \text{ V}$, $I_O = 2.4 \text{ mA}$	SFH6136	V_{OL}		0.1	0.4	V
Output current, output high	$I_F = 0 \text{ mA}$, $V_O = V_{CC} = 5.5 \text{ V}$		I_{OH}		3.0	500	nA
	$I_F = 0 \text{ mA}$, $V_O = V_{CC} = 15 \text{ V}$		I_{OH}		0.01	1.0	μA

Coupler

Parameter	Test condition	Symbol	Min	Typ.	Max	Unit
Capacitance (input-output)	$f = 1.0 \text{ MHz}$	C_{IO}		0.6		pF

Current Transfer Ratio

Parameter	Test condition	Part	Symbol	Min	Typ.	Max	Unit
Current Transfer Ratio	$I_F = 16 \text{ mA}$, $V_O = 0.4 \text{ V}$, $V_{CC} = 4.5 \text{ V}$	SFH6135	CTR	7	16		%
		SFH6136	CTR	19	35		%
	$I_F = 16 \text{ mA}$, $V_O = 0.5 \text{ V}$, $V_{CC} = 4.5 \text{ V}$	SFH6135	CTR	5			%
		SFH6136	CTR	15			%

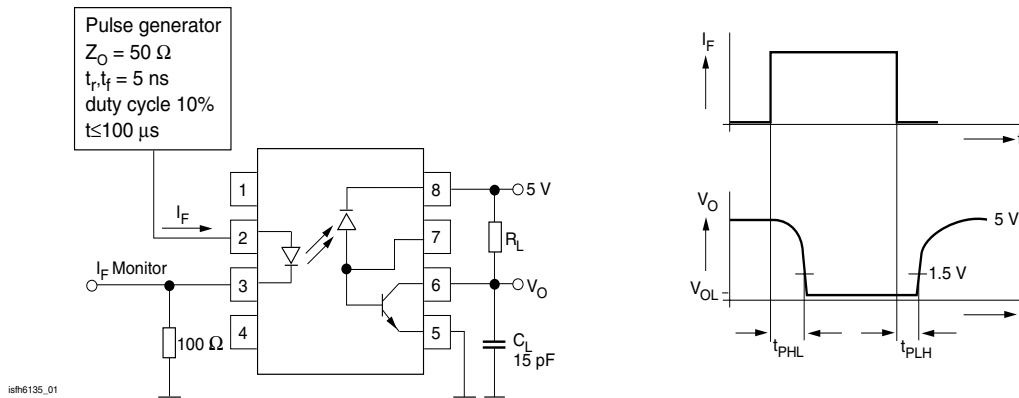
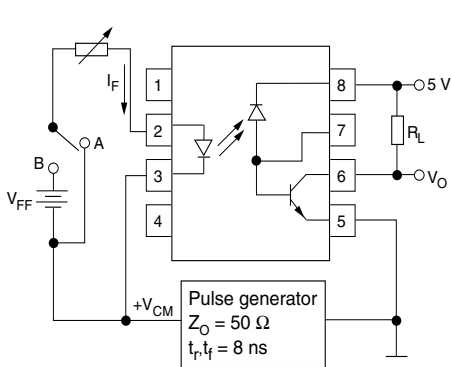

Fig. 1 Schematics

Switching Characteristics

Delay Time

Parameter	Test condition	Part	Symbol	Min	Typ.	Max	Unit
High-low	$I_F = 16 \text{ mA}$, $V_{CC} = 5.0 \text{ V}$, $R_L = 4.1 \text{ k}\Omega$	SFH6135	t_{PHL}		0.3	1.5	μs
	$I_F = 16 \text{ mA}$, $V_{CC} = 5.0 \text{ V}$, $R_L = 1.9 \text{ k}\Omega$	SFH6136	t_{PHL}		0.2	0.8	μs
Low-high	$I_F = 16 \text{ mA}$, $V_{CC} = 5.0 \text{ V}$, $R_L = 4.1 \text{ k}\Omega$	SFH6135	t_{PLH}		0.3	1.5	μs
	$I_F = 16 \text{ mA}$, $V_{CC} = 5.0 \text{ V}$, $R_L = 1.9 \text{ k}\Omega$	SFH6136	t_{PLH}		0.2	0.8	μs



is#6135_02

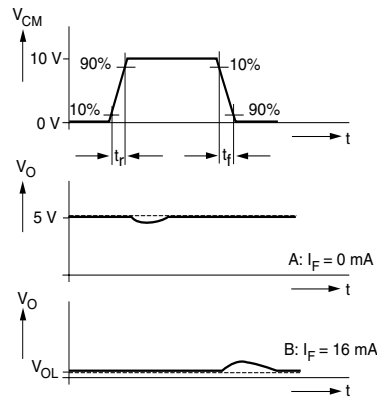

Fig. 2 Common-Mode Interference Immunity

Common Mode Transient Immunity

Parameter	Test condition	Part	Symbol	Min	Typ.	Max	Unit
High	$V_{CM} = 10 \text{ V}_{P-P}$, $V_{CC} = 5.0 \text{ V}$, $I_F = 0 \text{ mA}$, $R_L = 4.1 \text{ k}\Omega$	SFH6135	CM_H		1000		$\text{V}/\mu\text{s}$
	$V_{CM} = 10 \text{ V}_{P-P}$, $V_{CC} = 5.0 \text{ V}$, $I_F = 0 \text{ mA}$, $R_L = 1.9 \text{ k}\Omega$	SFH6136	CM_H		1000		$\text{V}/\mu\text{s}$
Low	$V_{CM} = 10 \text{ V}_{P-P}$, $V_{CC} = 5.0 \text{ V}$, $I_F = 0 \text{ mA}$, $R_L = 4.1 \text{ k}\Omega$	SFH6135	CM_L		1000		$\text{V}/\mu\text{s}$
	$V_{CM} = 10 \text{ V}_{P-P}$, $V_{CC} = 5.0 \text{ V}$, $I_F = 0 \text{ mA}$, $R_L = 1.9 \text{ k}\Omega$	SFH6136	CM_L		1000		$\text{V}/\mu\text{s}$

Typical Characteristics ($T_{amb} = 25\text{ }^{\circ}\text{C}$ unless otherwise specified)

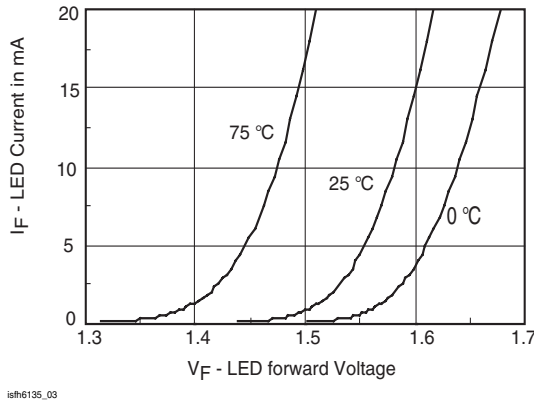

Fig. 3 LED Forward Current vs. Forward Voltage

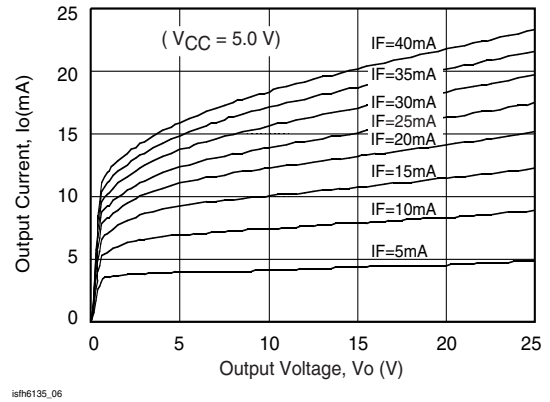

Fig. 6 Output Current vs. Output Voltage

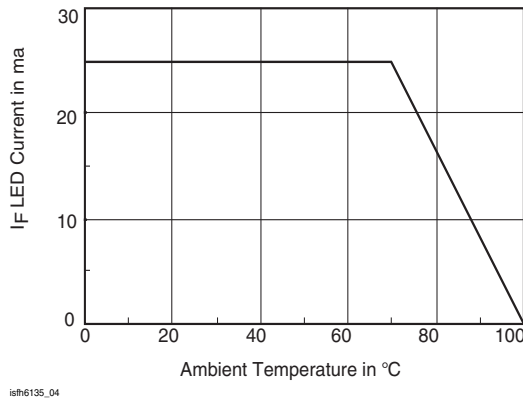

Fig. 4 Permissible Forward LED Current vs. Temperature

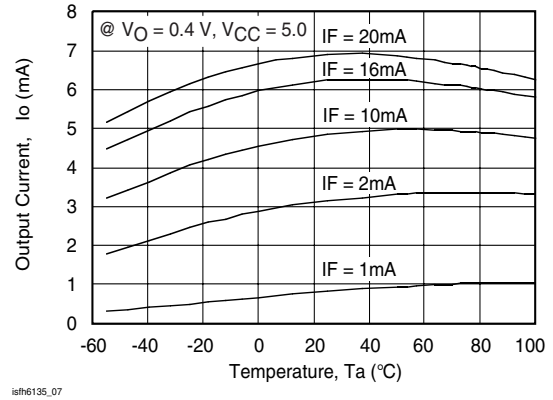

Fig. 7 Output Current vs. Temperature

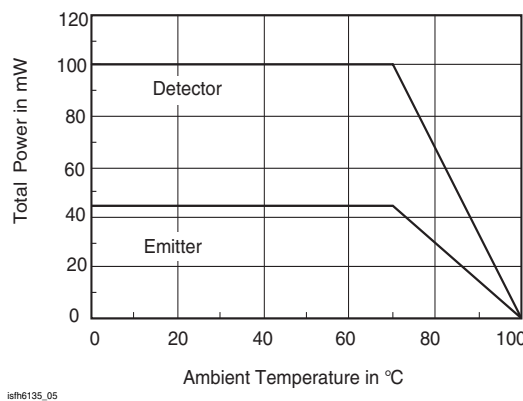

Fig. 5 Permissible Power Dissipation vs. Temperature

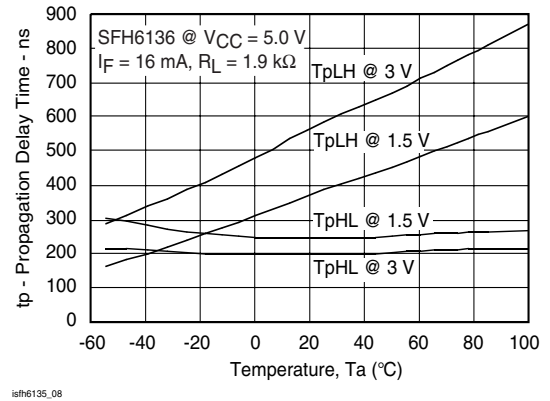
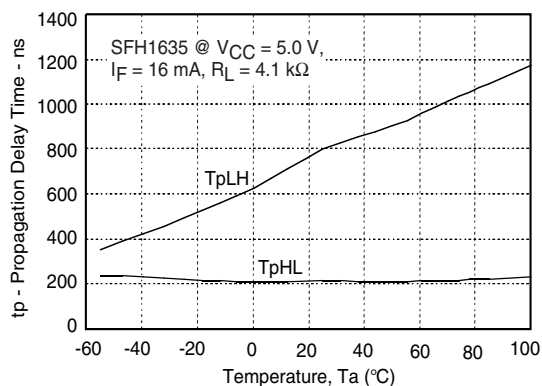
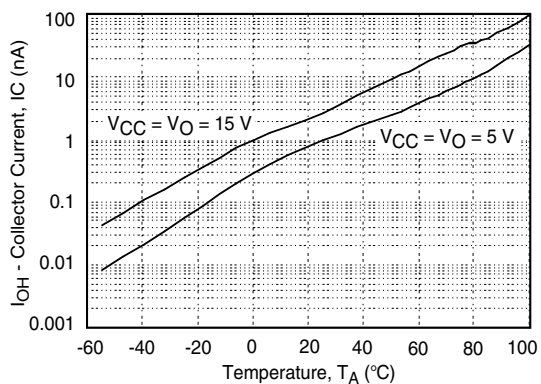

Fig. 8 Propagation Delay vs. Temperature-SFH6136



isfh6135_09

Fig. 9 Propagation Delay vs. Temperature-SFH6135



isfh6135_10

Fig. 10 Logic High Output Current vs. Temperature

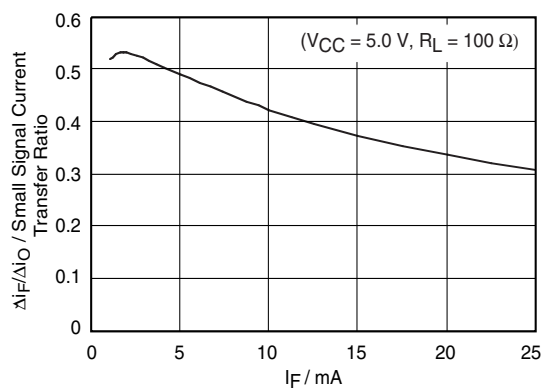

isfh6135_11

Fig. 11 Small Signal Current Transfer Ratio vs. Quiescent Input Current



Package Dimensions in Inches (mm)

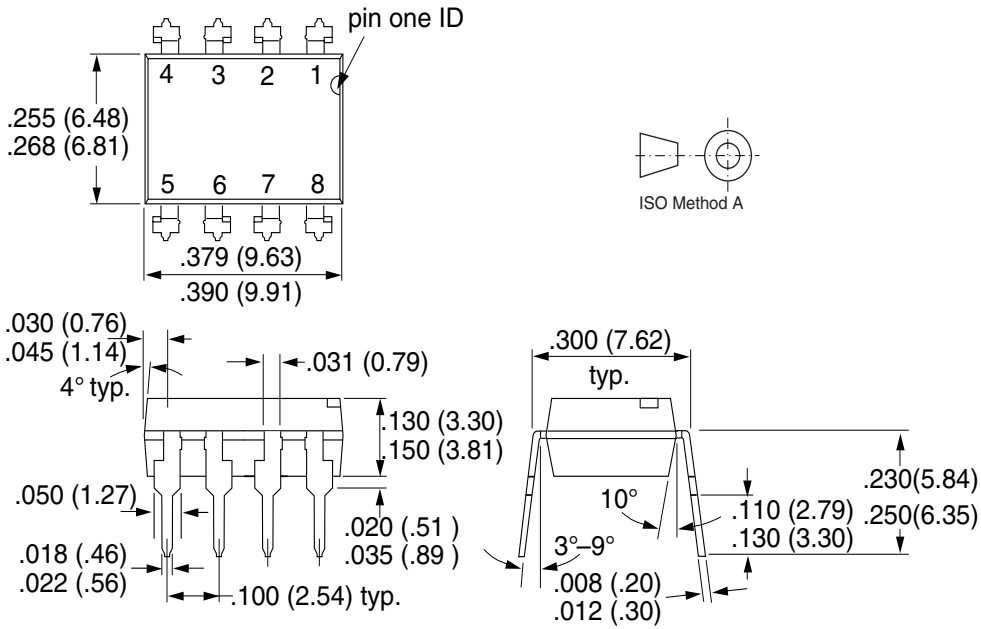

i178006

Ozone Depleting Substances Policy Statement

It is the policy of **Vishay Semiconductor GmbH** to

1. Meet all present and future national and international statutory requirements.
2. Regularly and continuously improve the performance of our products, processes, distribution and operating systems with respect to their impact on the health and safety of our employees and the public, as well as their impact on the environment.

It is particular concern to control or eliminate releases of those substances into the atmosphere which are known as ozone depleting substances (ODSs).

The Montreal Protocol (1987) and its London Amendments (1990) intend to severely restrict the use of ODSs and forbid their use within the next ten years. Various national and international initiatives are pressing for an earlier ban on these substances.

Vishay Semiconductor GmbH has been able to use its policy of continuous improvements to eliminate the use of ODSs listed in the following documents.

1. Annex A, B and list of transitional substances of the Montreal Protocol and the London Amendments respectively
2. Class I and II ozone depleting substances in the Clean Air Act Amendments of 1990 by the Environmental Protection Agency (EPA) in the USA
3. Council Decision 88/540/EEC and 91/690/EEC Annex A, B and C (transitional substances) respectively.

Vishay Semiconductor GmbH can certify that our semiconductors are not manufactured with ozone depleting substances and do not contain such substances.

**We reserve the right to make changes to improve technical design
and may do so without further notice.**

Parameters can vary in different applications. All operating parameters must be validated for each customer application by the customer. Should the buyer use Vishay Semiconductors products for any unintended or unauthorized application, the buyer shall indemnify Vishay Semiconductors against all claims, costs, damages, and expenses, arising out of, directly or indirectly, any claim of personal damage, injury or death associated with such unintended or unauthorized use.

Vishay Semiconductor GmbH, P.O.B. 3535, D-74025 Heilbronn, Germany
Telephone: 49 (0)7131 67 2831, Fax number: 49 (0)7131 67 2423