



High Speed Optocoupler, 1 MBd, Transistor Output

Features

- Surface Mountable
- Industry Standard SOIC-8 Footprint
- Compatible with Infrared Vapor Phase Reflow and Wave Soldering Processes
- Isolation Test Voltage, 3000 V_{RMS}
- Very High Common Mode Transient Immunity: 15000 V/ μ s at V_{CM} = 1500 V Guaranteed (SFH6343)
- High Speed: 1.0 Mb/s
- TTL Compatible

- Guaranteed AC and DC Performance Temperature: 0 °C to 70 °C
- Open Collector Output
- Pin Compatible with Agilent(HP) Optocouplers
 - SFH6315T-HCPL0500
 - SFH6316T-HCPL0501
 - SFH6343T-HCPL0453

Agency Approvals

- UL - File No. E52744 System Code Y
- CSA 93751
- DIN EN 60747-5-2(VDE0884)
DIN EN 60747-5-5 pending
Available with Option 1

Applications

Line Receivers
 Logic Ground Isolation
 Analog Signal Ground Isolation
 Replace Pulse Transformers

Description

The SFH6315T/ SFH6316T/ SFH6343T, high speed optocouplers, each consists of a GaAlAs infrared emitting diode, optically coupled with an integrated

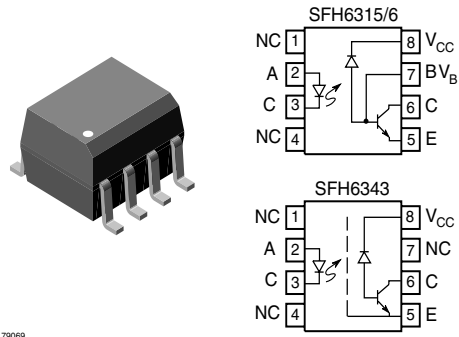

photo detector and a high speed transistor. The photo detector is junction isolated from the transistor to reduce miller capacitance effects. The open collector output function allows circuit designers to adjust the load conditions when interfacing with different logic systems such as TTL, CMOS, etc.

Because the SFH6343T has a Faraday shield on the detector chip, it can also reject and minimize high input to output common mode transient voltages. There is no base connection, further reducing the potential electrical noise entering the package.

The SFH6315T/ SFH6316T/ SFH6343T are packaged in industry standard SOIC-8 packages and are suitable for surface mounting.

Order Information

Part	Remarks
SFH6315T	CTR > 5.0 %, SOIC-8
SFH6316T	CTR > 15 %, SOIC-8
SFH6343T	CTR > 19 %, SOIC-8

For additional information on the available options refer to Option Information.

Note that product is available only on tape and reel.

Absolute Maximum Ratings

$T_{amb} = 25\text{ }^{\circ}\text{C}$, unless otherwise specified

Stresses in excess of the absolute Maximum Ratings can cause permanent damage to the device. Functional operation of the device is not implied at these or any other conditions in excess of those given in the operational sections of this document. Exposure to absolute Maximum Rating for extended periods of the time can adversely affect reliability.

Input

Parameter	Test condition	Symbol	Value	Unit
Reverse voltage		V_R	3.0	V
DC forward current		I_F	25	mA
Surge forward current	$t_p \leq 1.0\ \mu\text{s}$, 300 pulses/s	I_{FSM}	1.0	A
Power dissipation	$T_{amb} \leq 70\text{ }^{\circ}\text{C}$	P_{diss}	45	mW

Output

Parameter	Test condition	Symbol	Value	Unit
Supply voltage		V_S	- 0.5 to 30	V
Output voltage		V_O	- 0.5 to 25	V
Output current		I_O	8.0	mA
Power dissipation	$T_{amb} \leq 70\text{ }^{\circ}\text{C}$	P_{diss}	100	mW

Coupler

Parameter	Test condition	Symbol	Value	Unit
Isolation test voltage between emitter and detector (refer to climate DIN 40046, part 2, Nov.74)		V_{ISO}	3000	V_{RMS}
Pollution degree (DIN VDE 0110)			2	
Creepage			≥ 4.0	mm
Clearance			≥ 4.0	mm
Comparative tracking index per DIN IEC 112/VDE 0303, part 1			175	
Isolation resistance	$V_{IO} = 500\text{ V}$, $T_{amb} = 25\text{ }^{\circ}\text{C}$, R_{ISOL} (Note 2)	R_{IO}	$\geq 10^{12}$	Ω
	$V_{IO} = 500\text{ V}$, $T_{amb} = 100\text{ }^{\circ}\text{C}$, R_{ISOL} (Note 2)	R_{IO}	$\geq 10^{11}$	Ω
Storage temperature range		T_{stg}	-55 to +150	$^{\circ}\text{C}$
Ambient temperature range		T_{amb}	-55 to +100	$^{\circ}\text{C}$
Junction temperature		T_j	100	$^{\circ}\text{C}$
Soldering temperature	$t = 10\text{ s max.}$, Dip soldering: distance to seating plane $\geq 1.5\text{ mm}$		260	$^{\circ}\text{C}$



Electrical Characteristics

T_{amb} = 25 °C, unless otherwise specified

Minimum and maximum values are testing requirements. Typical values are characteristics of the device and are the result of engineering evaluation. Typical values are for information only and are not part of the testing requirements.

Input

Over recommend temperature (T_{amb} = 0 °C to 70 °C) unless otherwise specified. See note 6. All typical values at T_{amb} = 25 °.

Parameter	Test condition	Symbol	Min	Typ.	Max	Unit
Input forward voltage	I _F = 16 mA	V _F		1.6	1.8	V
		V _F		1.6	1.9	V
Input reverse current	V _R = 3.0 V	I _R		0.5	10	μA
Input capacitance	f = 1.0 MHz, V _F = 0 V	C _{IN}		75		pF
Temperature coefficient of forward voltage	I _F = 16 mA	ΔV _F /ΔT _{amb}		-1.7		mV/°C

Output

Parameter	Test condition	Part	Symbol	Min	Typ.	Max	Unit
Logic low supply current	I _F = 16 mA, V _O = Open, V _{CC} = 15 V		I _{CCL}		200		μA
Logic high supply current	I _F = 0 mA, V _O = Open, V _{CC} = 15 V		I _{CCH}		0.001	1.0	μA
			I _{CCH}		0.001	2.0	μA
Logic low output voltage	I _F = 16 mA, V _{CC} = 4.5 V, I _O = 1.1 mA	SFH6315T	V _{OL}		0.15	0.4	V
	I _F = 16 mA, V _{CC} = 4.5 V, I _O = 0.8 mA,	SFH6315T	V _{OL}		0.15	0.5	V
	I _F = 16 mA, V _{CC} = 4.5 V, I _O = 3.0 mA	SFH6316T	V _{OL}		0.15	0.4	V
	I _F = 16 mA, V _{CC} = 4.5 V, I _O = 2.4 mA,	SFH6343T	V _{OL}		0.15	0.5	V
Logic high output current	I _F = 0 mA, V _O = V _{CC} = 5.5 V		I _{OH}		0.003	0.5	μA
	I _F = 0 mA, V _O = V _{CC} = 15 V		I _{OH}		0.01	1.0	μA
			I _{OH}				50

Coupler

Parameter	Test condition	Symbol	Min	Typ.	Max	Unit
Capacitance (input-output). See note 6.	f = 1.0 MHz	C _{IO}		0.4		pF

Current Transfer Ratio

Parameter	Test condition	Part	Symbol	Min	Typ.	Max	Unit
Current Transfer Ratio See notes 1 and 6	V _O = 0.4 V, I _F = 16 mA, V _{CC} = 4.5 V	SFH6315T	CTR	7	16	50	%
	V _O = 0.5 V, I _F = 16 mA, V _{CC} = 4.5 V	SFH6315T	CTR	5	17		%
	V _O = 0.4 V, I _F = 16 mA, V _{CC} = 4.5 V	SFH6316T	CTR	19	35	50	%
	V _O = 0.5 V, I _F = 16 mA, V _{CC} = 4.5 V	SFH6343T	CTR	15	36		%

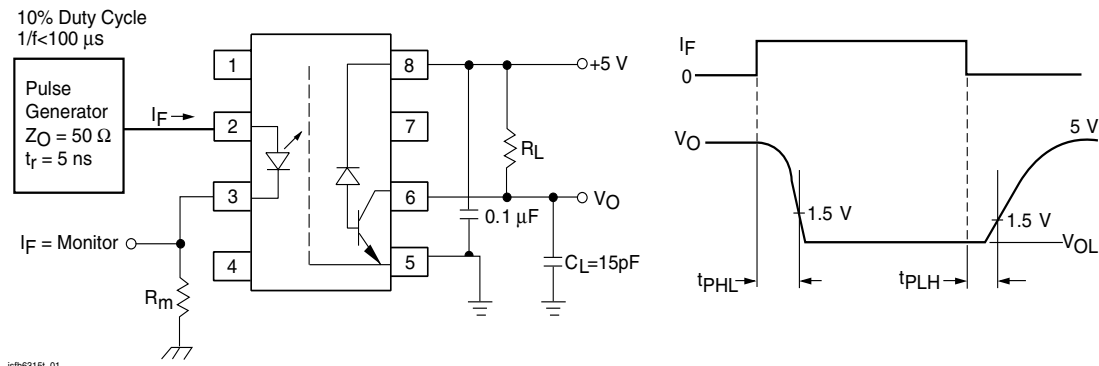

Fig. 1 Test Circuit for Switching Times

Switching Characteristics

Over recommended temperature (T_{amb} = 0°C), V_{CC} = 5.0 V, I_F = 16 mA unless otherwise specified. All typical values, T_{amb} = 25 °C

Parameter	Test condition	Part	Symbol	Min	Typ.	Max	Unit
Propagation delay time to logic low at output See fig. 1 and notes 4 and 5	R _L = 4.1 KΩ	SFH6315T	t _{PHL}		0.5	1.5	μs
		SFH6315T	t _{PHL}		0.5	2.0	μs
	R _L = 1.9 KΩ	SFH6316T	t _{PHL}		0.25	0.8	μs
		SFH6343T	t _{PHL}		0.25	1.0	μs
Propagation delay time to logic high at output See fig. 1 and notes 4 and 5	R _L = 4.1 KΩ	SFH6315T	t _{PLH}		0.5	1.5	μs
		SFH6315T	t _{PLH}		0.5	2.0	μs
	R _L = 1.9 KΩ	SFH6316T	t _{PLH}		0.5	0.8	μs
	R _L = 1.9 KΩ	SFH6343T	t _{PLH}		0.5	1.0	μs

Common Mode Transient Immunity

Parameter	Test condition	Part	Symbol	Min	Typ.	Max	Unit
Common mode transient immunity at logic high level output See fig. 2 and notes 3,4 and 5	$R_L = 4.1\text{ K}\Omega$, $I_F = 0\text{ mA}$, $V_{CM} = 10\text{ V}_{P-P}$	SFH6315T	ICM_{Hl}		1.0		$\text{KV}/\mu\text{s}$
	$R_L = 1.9\text{ K}\Omega$, $I_F = 0\text{ mA}$, $V_{CM} = 1500\text{ V}_{P-P}$	SFH6316T	ICM_{Hl}		1.0		$\text{KV}/\mu\text{s}$
		SFH6343T	ICM_{Hl}	15	30		$\text{KV}/\mu\text{s}$
Common mode transient immunity at logic low level output See fig. 2 and notes 3,4 and 5	$R_L = 4.1\text{ K}\Omega$, $I_F = 16\text{ mA}$, $V_{CM} = 10\text{ V}_{P-P}$	SFH6315T	ICM_{Ll}		1.0		$\text{KV}/\mu\text{s}$
	$R_L = 1.9\text{ K}\Omega$, $I_F = 16\text{ mA}$, $V_{CM} = 10\text{ V}_{P-P}$	SFH6316T	ICM_{Ll}		1.0		$\text{KV}/\mu\text{s}$
		SFH6343T	ICM_{Ll}	15	30		$\text{KV}/\mu\text{s}$

1. Current transfer ratio in percent equals the ratio of output collector current (I_O) to the forward LED input current (I_F) times 100
2. Device considered a two-terminal device: pins 1, 2, 3, and 4 shorted together and pins 5, 6, 7, and 8 shorted together.
3. Common mode transient immunity in a Logic High level is the maximum tolerable (positive) dV_{CM}/dt on the leading edge of the common mode pulse (V_{CM}) to assure that the output will remain in a Logic High state (i.e., $V_O > 2.0\text{ V}$). Common mode transient immunity in a Logic Low level the maximum tolerable (negative) dV_{CM}/dt on the trailing edge of the common mode pulse signal (V_{CM}) to assure that the output will remain in Logic Low state, i.e., $V_O > 0.8\text{ V}$.
4. The 1.9 k Ω load represents 1 TTL unit load of 1.6 mA and the 5.6 k Ω pull-up resistor.
5. The 4.1 k Ω load represents 1 LSTTL unit load of 0.36 mA and the 6.1 k Ω pull-up resistor.
6. A 0.1 μf bypass capacitor connected between pins 5 and 8 is recommended.

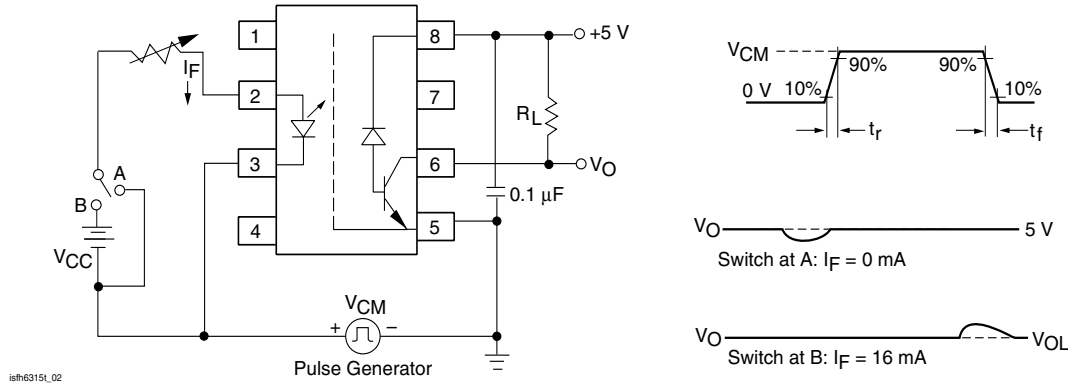
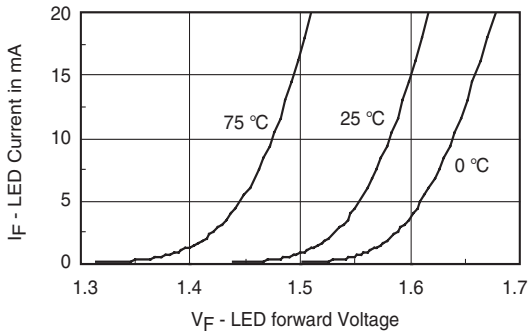

Fig. 2 Test Circuit for Transient Immunity and Typical Waveforms

Typical Characteristics ($T_{amb} = 25\text{ }^{\circ}\text{C}$ unless otherwise specified)



isfh6315t_03

Fig. 3 LED Forward Current vs. Forward Voltage

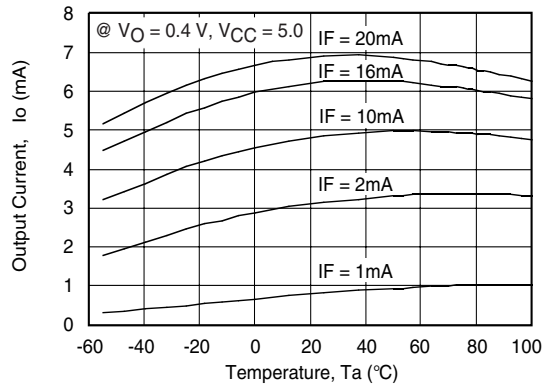

isfh6315t_07

Fig. 6 Output Current vs. Temperature

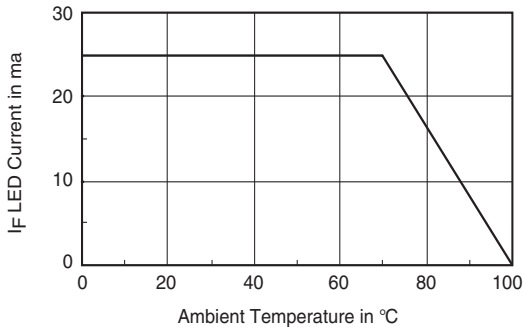

isfh6315t_04

Fig. 4 Permissible Forward LED Current vs. Temperature

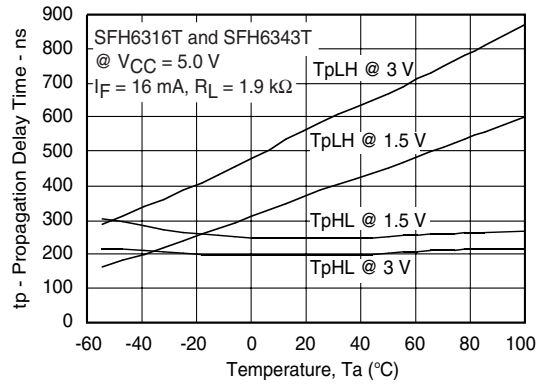

isfh6315t_08

Fig. 7 Propagation Delay vs. Temperature-SFH6316T and SFH6343T

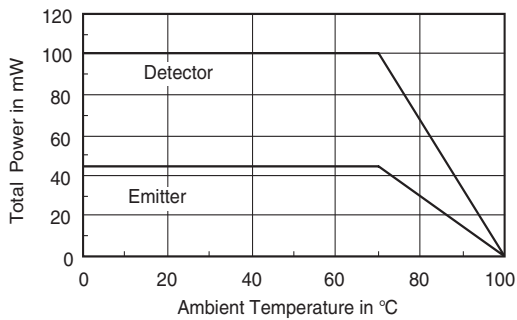

isfh6315t_05

Fig. 5 Permissible Power Dissipation vs. Temperature

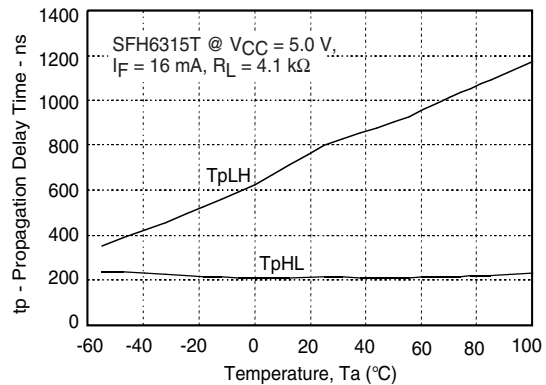

isfh6315t_09

Fig. 8 Propagation Delay vs. Temperature-SFH6315T

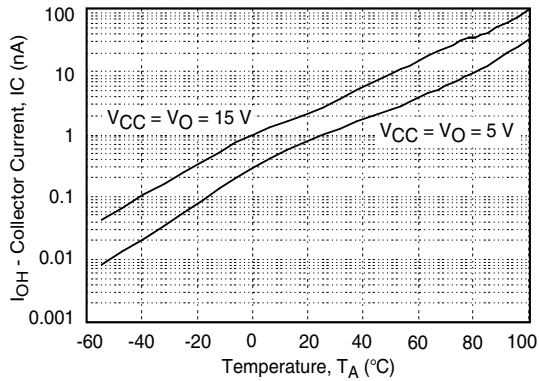

isfh6315t_10

Fig. 9 Logic High Output Current vs. Temperature

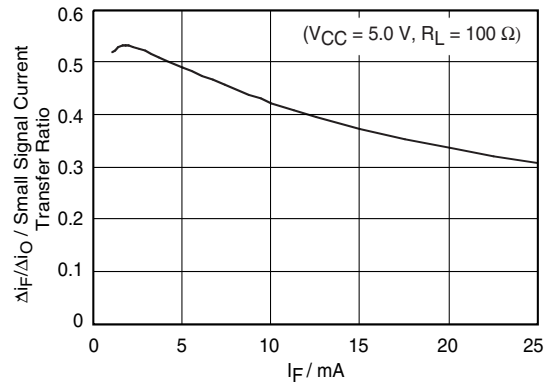

isfh6315t_11

Fig. 10 Small Signal Current Transfer Ratio vs. Quiescent Input Current

Package Dimensions in Inches (mm)

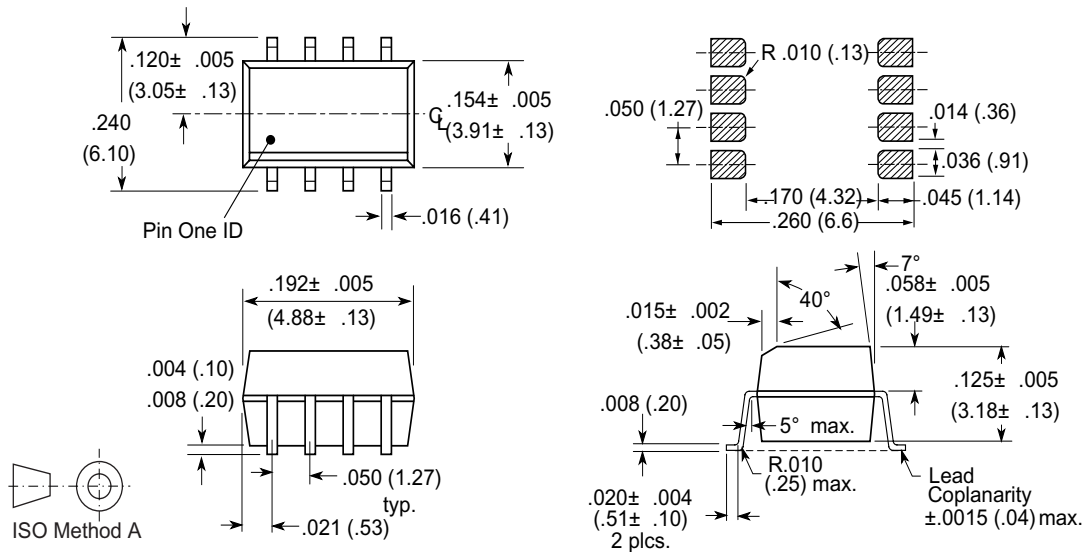

i178003

Ozone Depleting Substances Policy Statement

It is the policy of **Vishay Semiconductor GmbH** to

1. Meet all present and future national and international statutory requirements.
2. Regularly and continuously improve the performance of our products, processes, distribution and operating systems with respect to their impact on the health and safety of our employees and the public, as well as their impact on the environment.

It is particular concern to control or eliminate releases of those substances into the atmosphere which are known as ozone depleting substances (ODSs).

The Montreal Protocol (1987) and its London Amendments (1990) intend to severely restrict the use of ODSs and forbid their use within the next ten years. Various national and international initiatives are pressing for an earlier ban on these substances.

Vishay Semiconductor GmbH has been able to use its policy of continuous improvements to eliminate the use of ODSs listed in the following documents.

1. Annex A, B and list of transitional substances of the Montreal Protocol and the London Amendments respectively
2. Class I and II ozone depleting substances in the Clean Air Act Amendments of 1990 by the Environmental Protection Agency (EPA) in the USA
3. Council Decision 88/540/EEC and 91/690/EEC Annex A, B and C (transitional substances) respectively.

Vishay Semiconductor GmbH can certify that our semiconductors are not manufactured with ozone depleting substances and do not contain such substances.

**We reserve the right to make changes to improve technical design
and may do so without further notice.**

Parameters can vary in different applications. All operating parameters must be validated for each customer application by the customer. Should the buyer use Vishay Semiconductors products for any unintended or unauthorized application, the buyer shall indemnify Vishay Semiconductors against all claims, costs, damages, and expenses, arising out of, directly or indirectly, any claim of personal damage, injury or death associated with such unintended or unauthorized use.

Vishay Semiconductor GmbH, P.O.B. 3535, D-74025 Heilbronn, Germany
Telephone: 49 (0)7131 67 2831, Fax number: 49 (0)7131 67 2423