

High Speed Optocoupler, 1 Mbd, 15 kV/ms CMR, Transistor Output

Features

- Direct Replacement for HCPL4503
- High Speed Optocoupler without Base Connection
- Isolation Test Voltage: 5300 V_{RMS}
- GaAlAs Emitter
- Integrated Detector with Photo diode and Transistor
- High Data Transmission Rate: 1 MBit/s
- TTL Compatible
- Open Collector Output
- Good CTR Linearity Relative to Forward Current
- Field Effect Stable
- Low Coupling Capacitance
- Very High Common Mode Transient Immunity
dV/dt: ≥ 15 kV/μs at V_{CM} = 1500 V

Agency Approvals

- UL - File No. E52744 System Code H or J
- DIN EN 60747-5-2(VDE0884)
DIN EN 60747-5-5 pending
Available with Option 1

Applications

Data Communications
IGBT Drivers
Programmable Controllers

Description

The SFH6345 is an optocoupler with a GaAlAs infrared emitting diode, optically coupled to an integrated photo detector consisting of a photo diode and a high

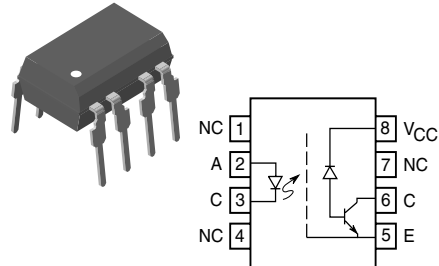

I179072

speed transistor in a DIP-8 plastic package. The device is similar to the 6N135 but has an additional Faraday shield on the detector which enhances the input-output dv/dt immunity.

Signals can be transmitted between two electrically separated circuits up to frequencies of 2 MHz. The potential difference between the circuits to be coupled should not exceed the maximum permissible reference voltages.

Order Information

Part	Remarks
SFH6345	CTR 30 %, DIP-8
SFH6345-X006	CTR 30 %, DIP-8 400 mil (option 6)
SFH6345-X007	CTR 30 %, SMD-8 (option 7)
SFH6345-X009	CTR 30 %, SMD-8 (option 9)

For additional information on the available options refer to Option Information.

Absolute Maximum Ratings

$T_{amb} = 25\text{ °C}$, unless otherwise specified

Stresses in excess of the absolute Maximum Ratings can cause permanent damage to the device. Functional operation of the device is not implied at these or any other conditions in excess of those given in the operational sections of this document. Exposure to absolute Maximum Rating for extended periods of the time can adversely affect reliability.

Input

Parameter	Test condition	Symbol	Value	Unit
Reverse voltage		V_R	3	V
DC forward current		I_F	25	mA
Surge forward current	$t_p \leq 1\ \mu\text{s}$, 300 pulses/sec.	I_{FSM}	1	A
Power dissipation		P_{diss}	45	mW

Output

Parameter	Test condition	Symbol	Value	Unit
Supply voltage		V_S	- 0.5 to 30	V
Output voltage		V_O	- 0.5 to 25	V
Output current		I_O	8	mA
Power dissipation		P_{diss}	100	mW

Coupler

Parameter	Test condition	Symbol	Value	Unit
Isolation test voltage between emitter and detector (refer to climate DIN 40046, part 2, Nov. 74)		V_{ISO}	5300	V_{RMS}
Creepage			≥ 7	mm
Clearance			≥ 7	mm
Comparative tracking index per DIN IEC 112/VDE 0303, part 1			≥ 175	
Isolation resistance	$V_{IO} = 500\text{ V}$, $T_{amb} = 25\text{ °C}$	R_{IO}	$\geq 10^{12}$	Ω
	$V_{IO} = 500\text{ V}$, $T_{amb} = 100\text{ °C}$	R_{IO}	$\geq 10^{11}$	Ω
Storage temperature range		T_{stg}	- 55 to + 150	$^{\circ}\text{C}$
Ambient temperature range		T_{amb}	- 55 to + 100	$^{\circ}\text{C}$
Junction temperature		T_j	100	$^{\circ}\text{C}$
Soldering temperature	$t = 10\text{ sec. max}$, Dip soldering: distance to seating plane $\geq 1.5\text{ mm}$	T_{sld}	260	$^{\circ}\text{C}$

Electrical Characteristics

$T_{amb} = 25\text{ }^{\circ}\text{C}$, unless otherwise specified

Minimum and maximum values are testing requirements. Typical values are characteristics of the device and are the result of engineering evaluation. Typical values are for information only and are not part of the testing requirements.

Input

$T_{amb} = 0$ to $70\text{ }^{\circ}\text{C}$, unless otherwise specified, typical values $T_{amb} = 25\text{ }^{\circ}\text{C}$

Parameter	Test condition	Symbol	Min	Typ.	Max	Unit
Forward voltage	$I_F = 16\text{ mA}$	V_F		1.6	1.9	V
Reverse current	$V_R = 3\text{ V}$	I_R		0.5	10	μA
Capacitance	$V_R = 0\text{ V}$, $f = 1\text{ MHz}$	C_O		75		pF
Thermal resistance		R_{thja}		700		K/W

Output

Parameter	Test condition	Symbol	Min	Typ.	Max	Unit
Supply current, logic high	$I_F = 0$, $V_O = \text{open}$, $V_{CC} = 15\text{ V}$	I_{CCH}		0.01	1	μA
		I_{CCH}		0.01	2	μA
Output current, output high	$I_F = 0$, $V_O = V_{CC} = 5.5\text{ V}$	I_{OH}		.003	0.5	μA
	$I_F = 0$, $V_O = V_{CC} = 15\text{ V}$	I_{OH}		.01	1	
		I_{OH}				50
Collector-emitter capacitance	$V_{CE} = 5\text{ V}$, $f = 1\text{ MHz}$	C_{CE}		3		pF
Thermal resistance		R_{thja}		300		K/W

Coupler

Parameter	Test condition	Symbol	Min	Typ.	Max	Unit
Coupling capacitance		C_C		0.6		pF
Collector emitter saturation voltage	$I_F = 16\text{ mA}$, $I_O = 2.4\text{ mA}$, $V_{CC} = 4.5\text{ V}$	V_{OL}		0.1	0.4	V
Logic low supply current	$I_F = 16\text{ mA}$, $V_O = \text{open}$, $V_{CC} = 15\text{ V}$	I_{CCL}		80	200	μA

Current Transfer Ratio

Parameter	Test condition	Symbol	Min	Typ.	Max	Unit
Current Transfer Ratio	$I_F = 16\text{ mA}$, $V_O = 0.4\text{ V}$, $V_{CC} = 4.5\text{ V}$	I_C/I_F	19	30		%
	$I_F = 16\text{ mA}$, $V_O = 0.5\text{ V}$, $V_{CC} = 4.5\text{ V}$	I_C/I_F	15			%

Switching Characteristics

Parameter	Test condition	Symbol	Min	Typ.	Max	Unit
Propagation delay time (high-low), see fig. 1	$I_F = 16 \text{ mA}$, $V_{CC} = 5 \text{ V}$, $R_L = 1.9 \text{ k}\Omega$	t_{PHL}		0.3	0.8	μs
Propagation delay time (low-high), see fig. 1	$I_F = 16 \text{ mA}$, $V_{CC} = 5 \text{ V}$, $R_L = 1.9 \text{ k}\Omega$	t_{PLH}		0.3	0.8	μs

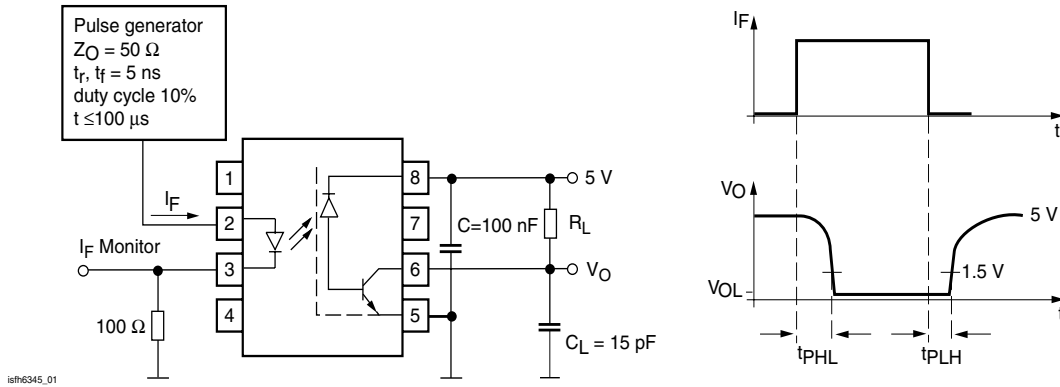

Fig. 1 Switching times (typ.)

Common Mode Transient Immunity

Parameter	Test condition	Symbol	Min	Typ.	Max	Unit
Common mode transient immunity (high), see fig. 2	$I_F = 0$, $V_{CM} = 1500 \text{ V}_{P-P}$ $R_L = 1.9 \text{ k}\Omega$, $V_{CC} = 5 \text{ V}$	$ CM_H $	15	30		$\text{kV}/\mu\text{s}$
Common mode transient immunity (low), see fig. 2	$I_F = 16 \text{ mA}$, $V_{CM} = 1500 \text{ V}_{P-P}$ $R_L = 1.9 \text{ k}\Omega$, $V_{CC} = 5 \text{ V}$	$ CM_L $	15	30		$\text{kV}/\mu\text{s}$

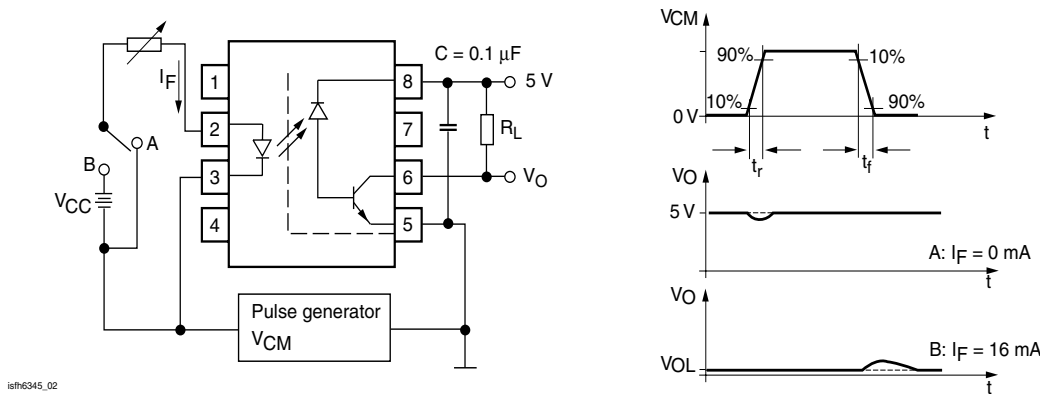

Fig. 2 Common mode transient immunity

Typical Characteristics ($T_{amb} = 25\text{ }^{\circ}\text{C}$ unless otherwise specified)

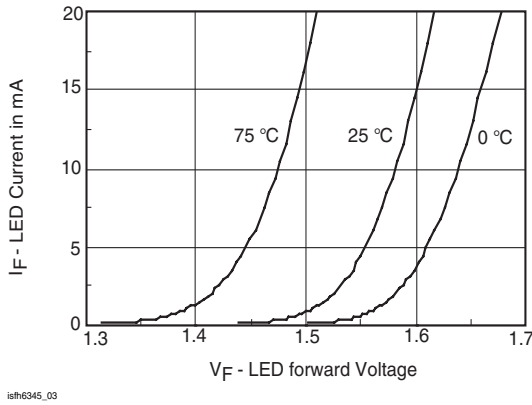

Fig. 3 Logic high output current vs. temperature

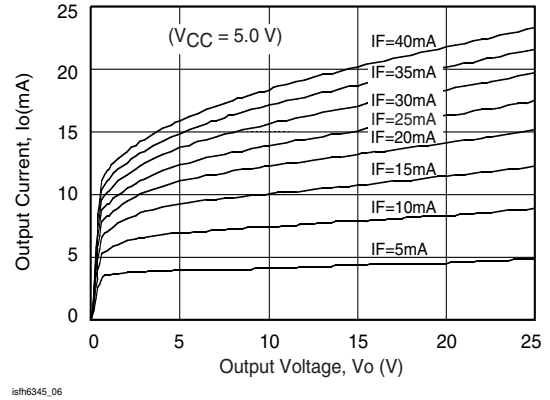

Fig. 6 Output Current vs. Output Voltage

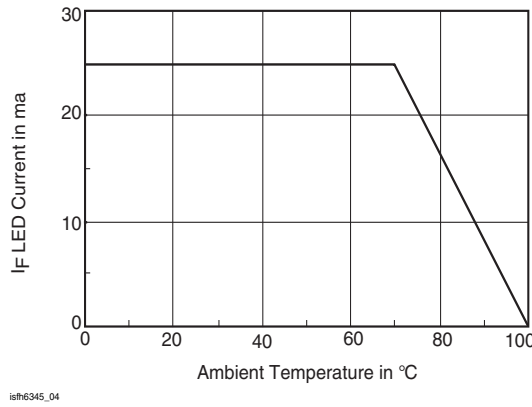

Fig. 4 Permissible Forward LED Current vs. Temperature

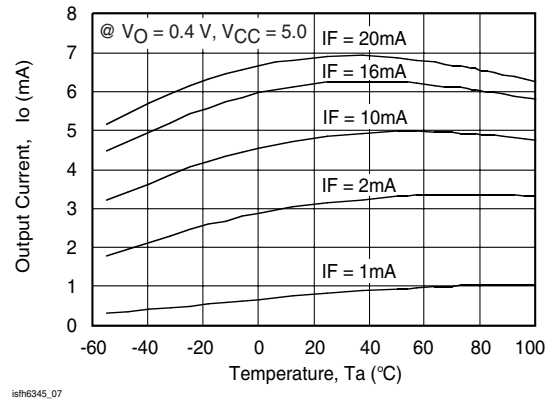

Fig. 7 Output Current vs. Temperature

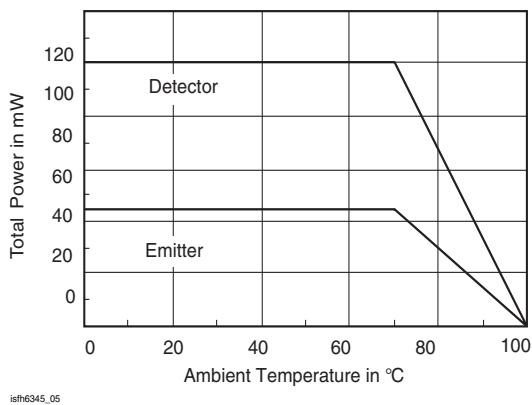

Fig. 5 Permissible Power Dissipation vs. Temperature

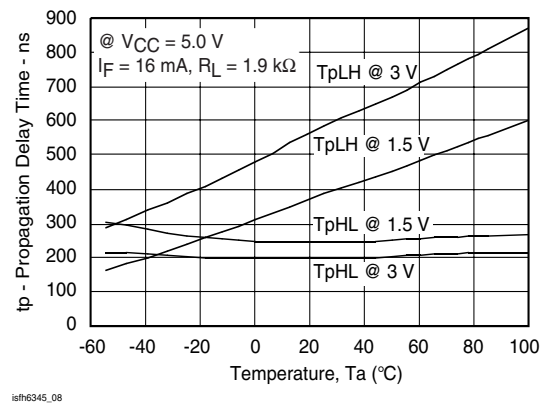
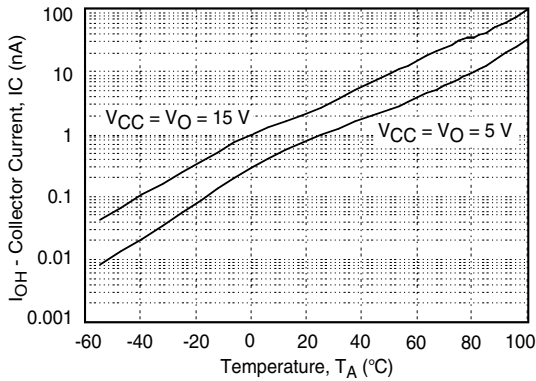
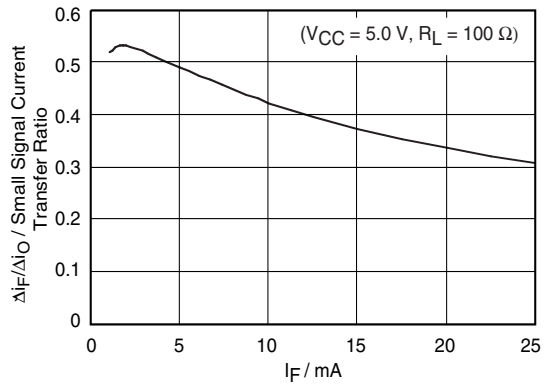

Fig. 8 Propagation Delay vs. Temperature



isfh6345_09

Fig. 9 Logic high output current vs. temperature



isfh6345_10

Fig. 10 Small Signal Current Transfer Ratio vs. Quiescent Input Current

Package Dimensions in Inches (mm)

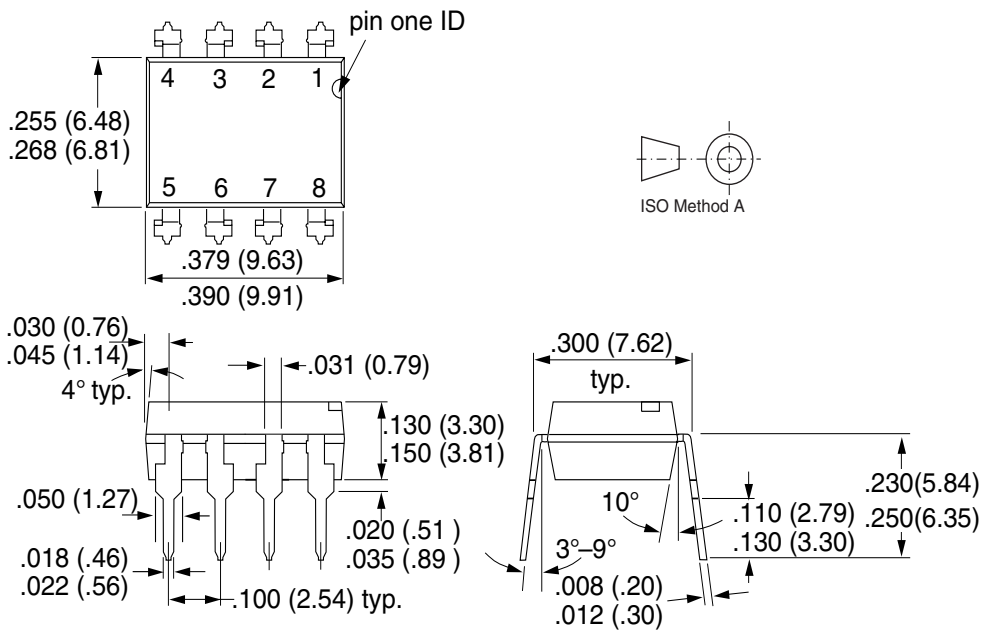

i178006

Option 6

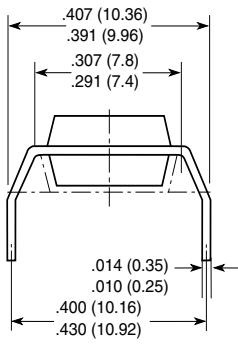

Option 7

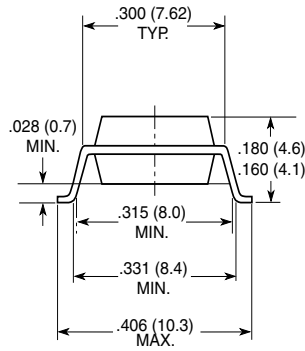

Option 9

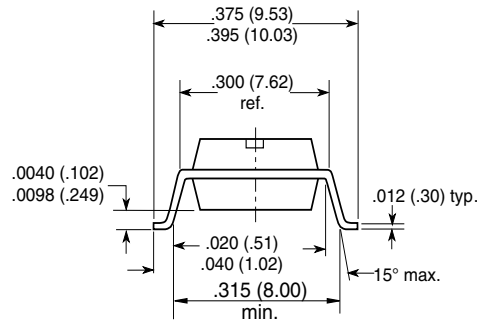

18450

Ozone Depleting Substances Policy Statement

It is the policy of **Vishay Semiconductor GmbH** to

1. Meet all present and future national and international statutory requirements.
2. Regularly and continuously improve the performance of our products, processes, distribution and operating systems with respect to their impact on the health and safety of our employees and the public, as well as their impact on the environment.

It is particular concern to control or eliminate releases of those substances into the atmosphere which are known as ozone depleting substances (ODSs).

The Montreal Protocol (1987) and its London Amendments (1990) intend to severely restrict the use of ODSs and forbid their use within the next ten years. Various national and international initiatives are pressing for an earlier ban on these substances.

Vishay Semiconductor GmbH has been able to use its policy of continuous improvements to eliminate the use of ODSs listed in the following documents.

1. Annex A, B and list of transitional substances of the Montreal Protocol and the London Amendments respectively
2. Class I and II ozone depleting substances in the Clean Air Act Amendments of 1990 by the Environmental Protection Agency (EPA) in the USA
3. Council Decision 88/540/EEC and 91/690/EEC Annex A, B and C (transitional substances) respectively.

Vishay Semiconductor GmbH can certify that our semiconductors are not manufactured with ozone depleting substances and do not contain such substances.

**We reserve the right to make changes to improve technical design
and may do so without further notice.**

Parameters can vary in different applications. All operating parameters must be validated for each customer application by the customer. Should the buyer use Vishay Semiconductors products for any unintended or unauthorized application, the buyer shall indemnify Vishay Semiconductors against all claims, costs, damages, and expenses, arising out of, directly or indirectly, any claim of personal damage, injury or death associated with such unintended or unauthorized use.

Vishay Semiconductor GmbH, P.O.B. 3535, D-74025 Heilbronn, Germany
Telephone: 49 (0)7131 67 2831, Fax number: 49 (0)7131 67 2423