

# Optocoupler, Phototransistor Output, 1 Mbd, 10 kV/ms CMR, Split Collector Transistor Output

## Features

- High Speed Optocoupler without Base Connection
- Isolation Test Voltage: 5300 V<sub>RMS</sub>
- GaAlAs Emitter
- Integrated Detector with Photo diode and Transistor
- High Data Transmission Rate: 1.0 MBit/s
- TTL Compatible
- Open Collector Output
- CTR at I<sub>F</sub> = 16 mA, V<sub>O</sub> = 0.4 V, V<sub>CC</sub> = 4.5 V, T<sub>amb</sub> = 25 °C: ≥ 19 %
- Good CTR Linearity Relative to Forward Current
- Low Coupling Capacitance
- dV/dt: typ. 10 kV/μs

## Agency Approvals

- UL - File No. E52744 System Code H or J
- DIN EN 60747-5-2(VDE0884)  
DIN EN 60747-5-5 pending  
Available with Option 1

## Applications

IGBT Drivers  
Data Communications  
Programmable Controllers

## Description

The SFH636 is an optocoupler with a GaAlAs infrared emitting diode, optically coupled to an integrated photo detector consisting of a photo diode and a high

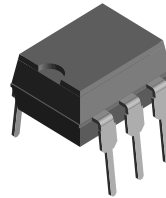

1179064

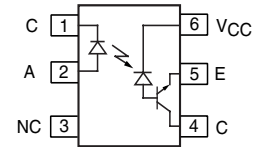

speed transistor in a DIP-6 plastic package. The device is functionally similar to 6N136 except there is no base connection, and the electrical foot print is different. Noise and dv/dt performance is enhanced by not bringing out the base connection.

Signals can be transmitted between two electrically separated circuits up to frequencies of 2.0 MHz. The potential difference between the circuits to be coupled should not exceed the maximum permissible reference

## Order Information

Part	Remarks
SFH636	CTR ≥ 19 %, DIP-6
SFH636-X006	CTR ≥ 19 %, DIP-6 400 mil (option 6)
SFH636-X007	CTR ≥ 19 %, SMD-6 (option 7)
SFH636-X009	CTR ≥ 19 %, SMD-6 (option9)

For additional information on the available options refer to Option Information.

## Absolute Maximum Ratings

$T_{amb} = 25\text{ }^{\circ}\text{C}$ , unless otherwise specified

Stresses in excess of the absolute Maximum Ratings can cause permanent damage to the device. Functional operation of the device is not implied at these or any other conditions in excess of those given in the operational sections of this document. Exposure to absolute Maximum Rating for extended periods of the time can adversely affect reliability.

### Input

Parameter	Test condition	Symbol	Value	Unit
Reverse voltage		$V_R$	3.0	V
DC Forward current		$I_F$	25	mA
Surge forward current	$t_p \leq 1.0\text{ }\mu\text{s}$ , 300 pulses/s	$I_{FSM}$	1.0	A
Power dissipation		$P_{diss}$	45	mW

### Output

Parameter	Test condition	Symbol	Value	Unit
Supply voltage		$V_S$	- 0.5 to 30	V
Output voltage		$V_O$	- 0.5 to 20	V
Output current		$I_O$	8.0	mA
Power dissipation		$P_{diss}$	100	mW

### Coupler

Parameter	Test condition	Symbol	Value	Unit
Isolation test voltage (between emitter and detector refer to climate DIN 40046, part 2, Nov. 74)		$V_{ISO}$	5300	$V_{RMS}$
Creepage			$\geq 7.0$	mm
Clearance			$\geq 7.0$	mm
Isolation resistance	$V_{IO} = 500\text{ V}$ , $T_{amb} = 25\text{ }^{\circ}\text{C}$	$R_{IO}$	$\geq 10^{12}$	$\Omega$
	$V_{IO} = 500\text{ V}$ , $T_{amb} = 100\text{ }^{\circ}\text{C}$	$R_{IO}$	$\geq 10^{11}$	$\Omega$
Storage temperature range		$T_{stg}$	- 55 to + 150	$^{\circ}\text{C}$
Ambient temperature range		$T_{amb}$	- 55 to + 100	$^{\circ}\text{C}$
Junction temperature		$T_j$	100	$^{\circ}\text{C}$
Soldering temperature Dip soldering: distance to seating plane $\geq 1.5\text{ mm}$	$t = 10\text{ s max.}$ Dip soldering: distance to seating plane $\geq 1.5\text{ mm}$	$T_{sld}$	260	$^{\circ}\text{C}$

## Electrical Characteristics

$T_{amb} = 25\text{ }^{\circ}\text{C}$ , unless otherwise specified

Minimum and maximum values are testing requirements. Typical values are characteristics of the device and are the result of engineering evaluation. Typical values are for information only and are not part of the testing requirements.

### Input

Parameter	Test condition	Symbol	Min	Typ.	Max	Unit
Forward voltage	$I_F = 16\text{ mA}$	$V_F$		1.5	1.8	V
Reverse current	$V_R = 3.0\text{ V}$	$I_R$		0.5	10	$\mu\text{A}$
Capacitance	$V_R = 0\text{ V}$ , $f = 1.0\text{ MHz}$	$C_O$		125		pF
Thermal resistance		$R_{thja}$		700		K/W

### Output

Parameter	Test condition	Symbol	Min	Typ.	Max	Unit
Logic high supply current	$I_F = 0\text{ V}$ , $V_O$ (open), $V_{CC}=15\text{ V}$	$I_{CCH}$		0.01	1.0	$\mu\text{A}$
	$I_F = 0\text{ V}$ , $V_O$ (open), $V_{CC} = 15\text{ V}$	$I_{CCH}$		0.01	2.0	$\mu\text{A}$
Output current, output high	$I_F = 0\text{ V}$ , $V_O$ (open), $V_{CC} = 5.5\text{ V}$	$I_{OH}$		.003	0.5	$\mu\text{A}$
	$I_F = 0\text{ V}$ , $V_O$ (open), $V_{CC} = 15\text{ V}$	$I_{OH}$		.01	1.0	$\mu\text{A}$
		$I_{OH}$				50
Collector-emitter capacitance	$V_{CE} = 5.0\text{ V}$ , $f = 1.0\text{ MHz}$	$C_{CE}$		3.0		pF
Thermal resistance		$R_{thja}$		300		K/W

### Coupler

Parameter	Test condition	Symbol	Min	Typ.	Max	Unit
Coupling capacitance		$C_C$		0.6		pF
Collector emitter saturation voltage	$I_F = 16\text{ mA}$ , $I_O = 2.4\text{ mA}$ , $V_{CC} = 4.5\text{ V}$	$V_{OL}$		0.1	0.4	V
Supply current, logic low	$I_F = 16\text{ mA}$ , $V_O$ open, $V_{CC} = 15\text{ V}$	$I_{DD}$		80		

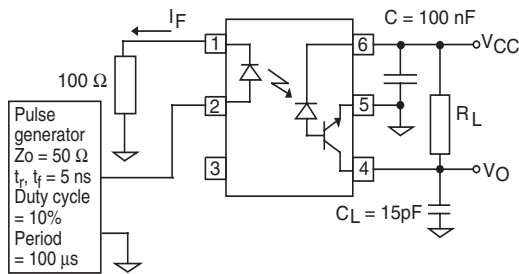

isth636\_01

Fig. 1 Test Set-up

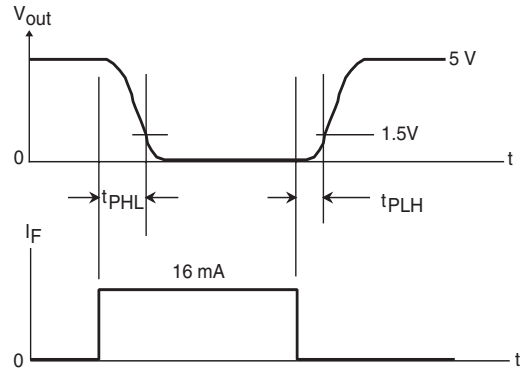

isth636\_02

Fig. 2 Switching Time Measurement

### Current Transfer Ratio

Parameter	Test condition	Symbol	Min	Typ.	Max	Unit
Current Transfer Ratio	$I_F = 16\text{ mA}$ , $V_O = 0.4\text{ V}$ , $V_{CC} = 4.5\text{ V}$	$I_C/I_F$	19	30		%
	$I_F = 16\text{ mA}$ , $V_O = 0.5\text{ V}$ , $V_{CC} = 4.5\text{ V}$	$I_C/I_F$	15			%

### Switching Characteristics

#### Switching Time Measurement

Parameter	Test condition	Symbol	Min	Typ.	Max	Unit
Propagation delay time (high-low)	$I_F = 16\text{ mA}$ , $V_{CC} = 5.0\text{ V}$ , $R_L = 1.9\text{ k}\Omega$	$t_{PHL}$		0.3	0.8	$\mu\text{s}$
Propagation delay time (low-low)	$I_F = 16\text{ mA}$ , $V_{CC} = 5.0\text{ V}$ , $R_L = 1.9\text{ k}\Omega$	$t_{PLH}$		0.3	0.8	$\mu\text{s}$

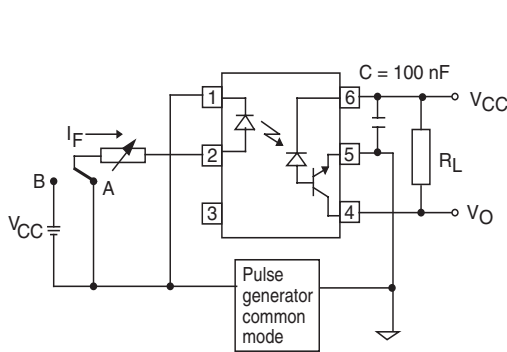

isfh636\_03

Fig. 3 Common Mode Transient Test

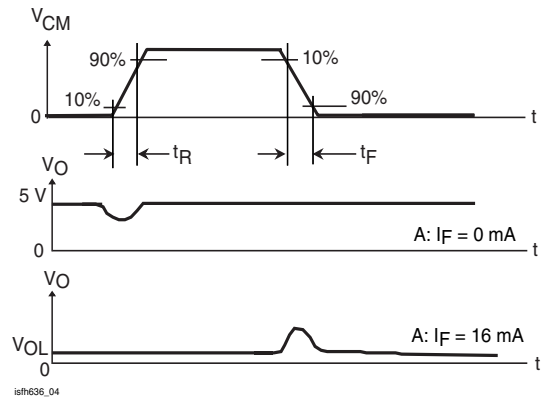

isfh636\_04

Fig. 4 Measurement Waveform of CMR

## Common Mode Transient Immunity

Parameter	Test condition	Symbol	Min	Typ.	Max	Unit
Common mode transient immunity (high)	$I_O = 0$ , $V_{CM} = 1500$ V <sub>P-P</sub> $R_L = 1.9$ k $\Omega$ , $V_{CC} = 5.0$ V	CM <sub>H</sub>		10		kV/ $\mu$ s
Common mode transient immunity (low)	$I_O = 16$ mA, $V_{CM} = 1500$ V <sub>P-P</sub> $R_L = 1.9$ k $\Omega$ , $V_{CC} = 5.0$ V	CM <sub>L</sub>		10		kV/ $\mu$ s

## Typical Characteristics ( $T_{amb} = 25$ °C unless otherwise specified)

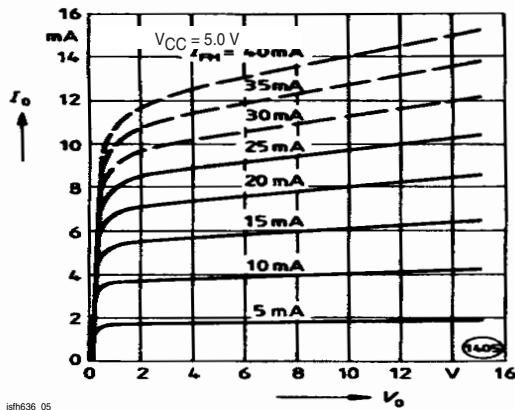

isfh636\_05

Fig. 5 Output Characteristics-Output Current vs. Output Voltage

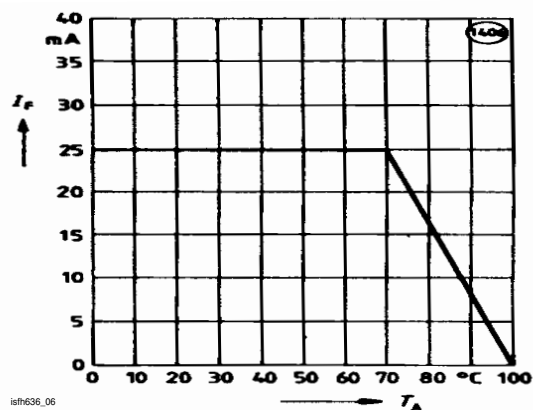

isfh636\_06

Fig. 6 Permissible Forward Current of Emitting Diode vs. Ambient Temperature

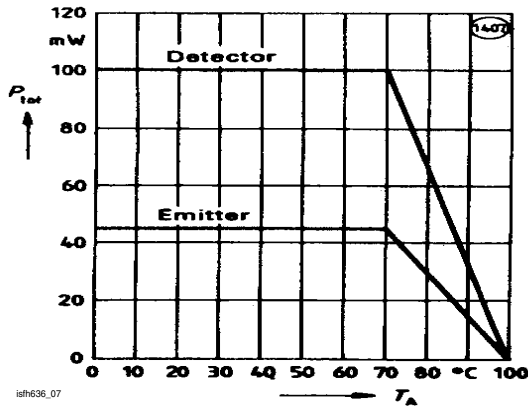

Fig. 7 Permissible Total Power Dissipation vs. Ambient Temperature

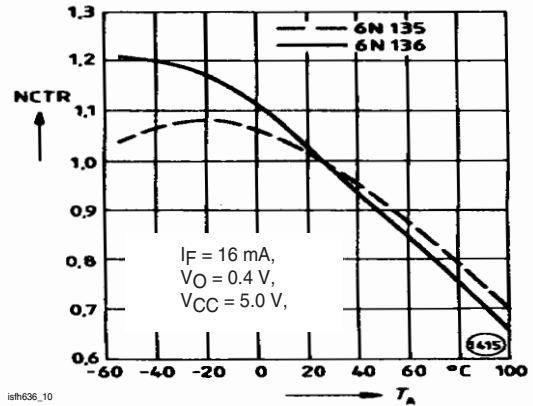

Fig. 10 Current Transfer Ratio (normalized) vs. Ambient Temperature

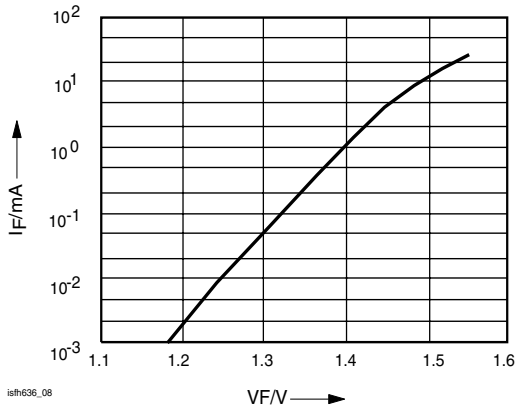

Fig. 8 Forward Current of Emitting Diode vs. Forward Voltage

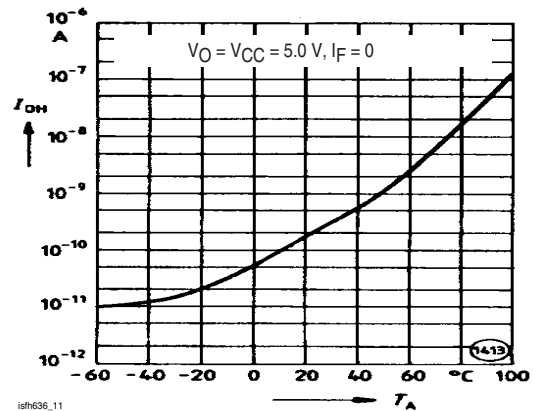

Fig. 11 Output Current (high) Vs. Ambient Temperature

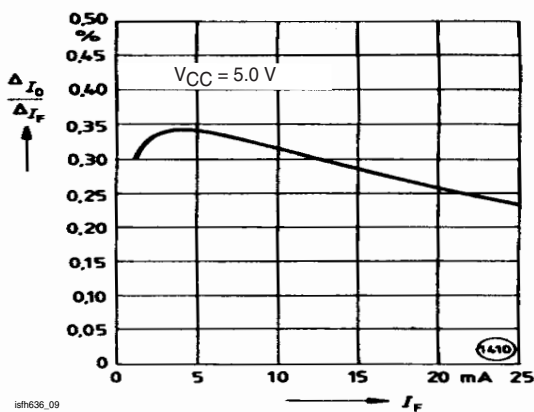

Fig. 9 Small Signal Transfer Ratio vs. Forward Current

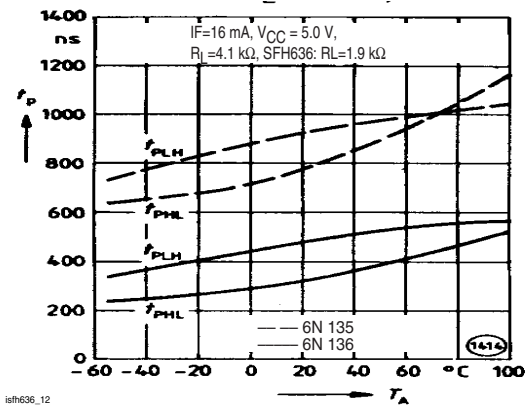

Fig. 12 Delay Times vs. Ambient Temperature

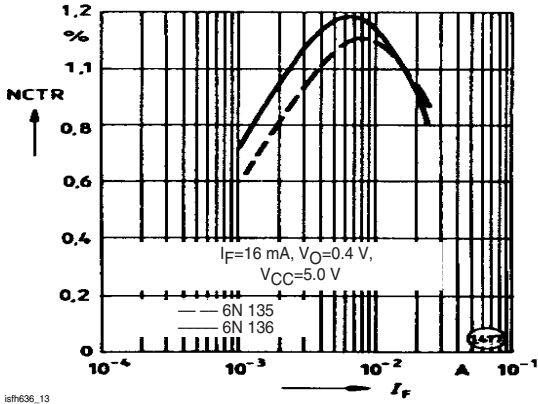
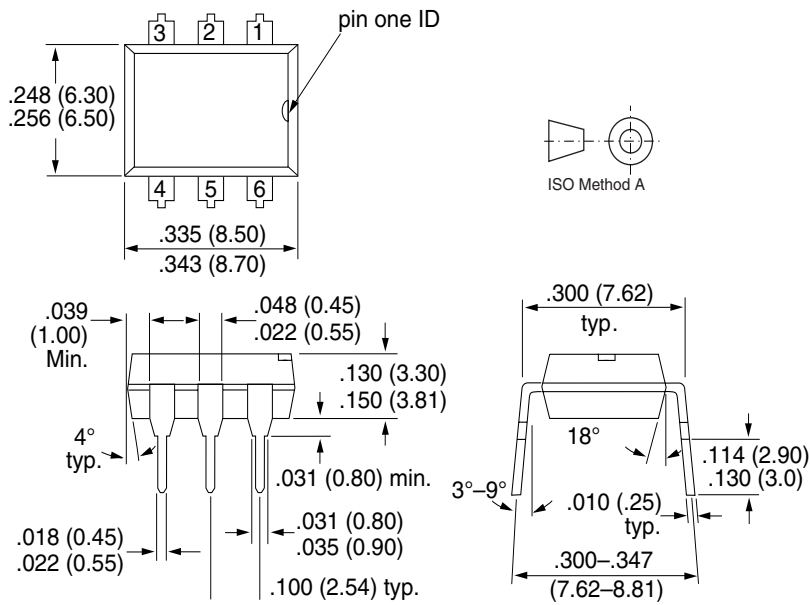

Fig. 13 Current Transfer Ratio (normalized) vs. Forward Current

## Package Dimensions in Inches (mm)



i178004

**Option 6**

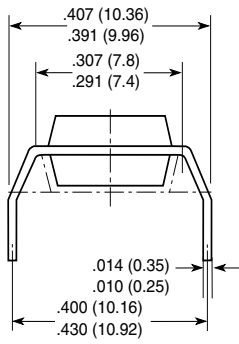

**Option 7**

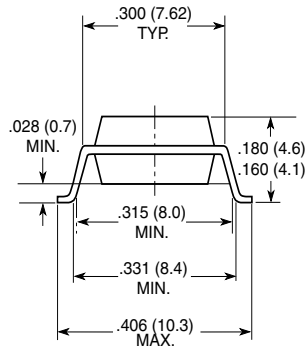

**Option 9**

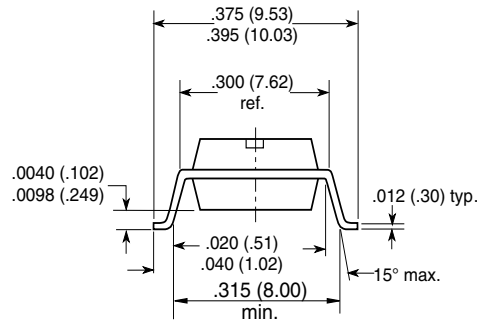

18450

### Ozone Depleting Substances Policy Statement

It is the policy of **Vishay Semiconductor GmbH** to

1. Meet all present and future national and international statutory requirements.
2. Regularly and continuously improve the performance of our products, processes, distribution and operating systems with respect to their impact on the health and safety of our employees and the public, as well as their impact on the environment.

It is particular concern to control or eliminate releases of those substances into the atmosphere which are known as ozone depleting substances (ODSs).

The Montreal Protocol (1987) and its London Amendments (1990) intend to severely restrict the use of ODSs and forbid their use within the next ten years. Various national and international initiatives are pressing for an earlier ban on these substances.

**Vishay Semiconductor GmbH** has been able to use its policy of continuous improvements to eliminate the use of ODSs listed in the following documents.

1. Annex A, B and list of transitional substances of the Montreal Protocol and the London Amendments respectively
2. Class I and II ozone depleting substances in the Clean Air Act Amendments of 1990 by the Environmental Protection Agency (EPA) in the USA
3. Council Decision 88/540/EEC and 91/690/EEC Annex A, B and C (transitional substances) respectively.

**Vishay Semiconductor GmbH** can certify that our semiconductors are not manufactured with ozone depleting substances and do not contain such substances.

**We reserve the right to make changes to improve technical design  
and may do so without further notice.**

Parameters can vary in different applications. All operating parameters must be validated for each customer application by the customer. Should the buyer use Vishay Semiconductors products for any unintended or unauthorized application, the buyer shall indemnify Vishay Semiconductors against all claims, costs, damages, and expenses, arising out of, directly or indirectly, any claim of personal damage, injury or death associated with such unintended or unauthorized use.

Vishay Semiconductor GmbH, P.O.B. 3535, D-74025 Heilbronn, Germany  
Telephone: 49 (0)7131 67 2831, Fax number: 49 (0)7131 67 2423