

## High Speed Optocoupler, 5 MBd, in SOIC-8 Package

### Features

- Data Rate 5.0 Mb/s (2.5 Mb/s over Temperature)
- Buffer
- Isolation Test Voltage, 3000 V<sub>RMS</sub> for 1.0 s
- TTL, LSTTL and CMOS Compatible
- Internal Shield for Very High Common Mode Transient Immunity
- Wide Supply Voltage Range (4.5 to 15 V)
- Low Input Current (1.6 mA to 5.0 mA)
- Specified from 0 °C to 85 °C

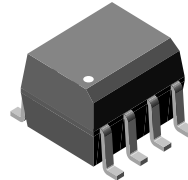

1179074

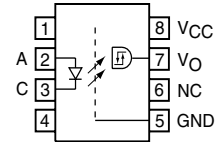

### Agency Approvals

- UL - File No. E52744 System Code Y
- DIN EN 60747-5-2(VDE0884)  
DIN EN 60747-5-5 pending  
Available with Option 1

transient immunity of 1000 V/μs at V<sub>CM</sub> = 50 V for SFH6720T and 2500 V/μs at V<sub>CM</sub> = 400 V for SFH6721T.

The SFH6720T and SFH6721T uses an industry standard SOIC-8A package.

### Applications

Industrial Control  
 Replace Pulse Transformers  
 Routine Logic Interfacing  
 Motion/Power Control  
 High Speed Line Receiver  
 Microprocessor System Interfaces  
 Computer Peripheral Interfaces

### Order Information

Part	Remarks
SFH6720T	CM <sub>H</sub>   > 1000, @   V <sub>CM</sub>   = 50 V, SOIC-8
SFH6721T	CM <sub>H</sub>   > 2500, @   V <sub>CM</sub>   = 400 V, SOIC-8

For additional information on the available options refer to Option Information.

Note Available only on tape and reel.

### Description

The single channel 5.0 Mb/s SFH6720T and SFH6721T high speed optocoupler consists of a GaAlAs infrared emitting diode, optically coupled with an integrated photo detector. The detector incorporates a Schmitt-Trigger stage for improved noise immunity. A Faraday shield provides a common mode

### Truth Table (Positive Logic)

Partnumber	IR Diode	Output
SFH6720T	on	H
	off	L
SFH6721T	on	H
	off	L

### Absolute Maximum Ratings

$T_{amb} = 25\text{ °C}$ , unless otherwise specified

Stresses in excess of the absolute Maximum Ratings can cause permanent damage to the device. Functional operation of the device is not implied at these or any other conditions in excess of those given in the operational sections of this document. Exposure to absolute Maximum Rating for extended periods of the time can adversely affect reliability.

### Input

Parameter	Test condition	Symbol	Value	Unit
Reverse voltage		$V_R$	3.0	V
DC Forward current		$I_F$	10	mA
Surge forward	$t_p \leq 1.0\ \mu\text{s}$ , 300 pulses/s	$I_{FSM}$	1.0	A
Power dissipation		$P_{diss}$	20	mW

### Output

Parameter	Test condition	Symbol	Value	Unit
Supply voltage		$V_{CC}$	- 0.5 to + 15	V
Output voltage		$V_O$	- 0.5 to + 15	V
Average output current		$I_O$	25	mA
Power dissipation		$P_{diss}$	100	mW

### Coupler

Parameter	Test condition	Symbol	Value	Unit
Storage temperature range		$T_{stg}$	- 55 to + 125	°C
Ambient temperature range		$T_{amb}$	- 40 to + 100	°C
Lead soldering temperature	$t = 10\ \text{s}$	$T_{sld}$	260	°C
Isolation test voltage	$t = 1.0\ \text{s}$	$V_{ISO}$	3000	$V_{RMS}$
Pollution degree			2	
Creepage distance and clearance			4.0	mm
Comparative tracking index per DIN IEC112/VDE 0303, part 1			175	
Isolation resistance	$V_{IO} = 500\ \text{V}$ , $T_{amb} = 25\text{ °C}$	$R_{IO}$	$10^{12}$	$\Omega$
	$V_{IO} = 500\ \text{V}$ , $T_{amb} = 100\text{ °C}$	$R_{IO}$	$10^{11}$	$\Omega$

### Recommended Operating Conditions

A 0.1  $\mu\text{F}$  bypass capacitor connected between pins 5 and 8 must be used.

Parameter	Test condition	Symbol	Min	Typ.	Max	Unit
Supply voltage		$V_{CC}$	4.5		15	V
Forward input current		$I_{Fon}$	1.6 <sup>(1)</sup>		5.0	mA
		$I_{Foff}$			0.1	mA
Operating temperature		$T_A$	- 40		85	°C

<sup>(1)</sup> We recommended using a 2.2 mA if to permit at least 20 % CTR degradation guard band.



### Electrical Characteristics

T<sub>amb</sub> = 25 °C, unless otherwise specified

Minimum and maximum values are testing requirements. Typical values are characteristics of the device and are the result of engineering evaluation. Typical values are for information only and are not part of the testing requirements.

### Input

- 40 °C ≤ T<sub>amb</sub> ≤ 85 °C; 4.5 V ≤ V<sub>CC</sub> ≤ 15 V; 1.6 mA ≤ I<sub>Fon</sub> ≤ 5.0 mA; 2.0 ≤ V<sub>EH</sub> ≤ 15 V; 0 ≤ V<sub>EL</sub> ≤ 0.8 V; 0 mA ≤ I<sub>Foff</sub> ≤ 0.1 mA

Typical values: T<sub>amb</sub> = 25 °C; V<sub>CC</sub> = 5.0 V; I<sub>Fon</sub> = 3.0 mA unless otherwise specified.

Parameter	Test condition	Symbol	Min	Typ.	Max	Unit
Forward voltage	I <sub>F</sub> = 5.0 mA	V <sub>F</sub>		1.6	1.75	V
		V <sub>F</sub>			1.9	V
Input current hysteresis	V <sub>CC</sub> = 5.0 V, I <sub>HYS</sub> = I <sub>Fon</sub> - I <sub>Foff</sub>	I <sub>HYS</sub>	0.1			V
Reverse current	V <sub>R</sub> = 3.0 V	I <sub>R</sub>		0.5	10	μA
Capacitance	V <sub>R</sub> = 0 V, f = 1.0 MHz	C <sub>O</sub>		60		pF
Thermal resistance		R <sub>thja</sub>		700		K/W

### Output

- 40 °C ≤ T<sub>amb</sub> ≤ 85 °C; 4.5 V ≤ V<sub>CC</sub> ≤ 15 V; 1.6 mA ≤ I<sub>Fon</sub> ≤ 5.0 mA; 2.0 ≤ V<sub>EH</sub> ≤ 15 V; 0 ≤ V<sub>EL</sub> ≤ 0.8 V; 0 mA ≤ I<sub>Foff</sub> ≤ 0.1 mA

Typical values: T<sub>amb</sub> = 25 °C; V<sub>CC</sub> = 5.0 V; I<sub>Fon</sub> = 3.0 mA unless otherwise specified.

Parameter	Test condition	Symbol	Min	Typ.	Max	Unit
Logic low output voltage	I <sub>OL</sub> = 6.4 mA	V <sub>OL</sub>			0.5	V
Logic high output voltage	I <sub>OH</sub> = - 2.6 mA, * V <sub>OH</sub> = V <sub>CC</sub> - 1.8 V	V <sub>OH</sub>	2.4			V
Output leakage current (V <sub>UT</sub> > V <sub>CC</sub> )	V <sub>O</sub> = 5.5 V, V <sub>CC</sub> = 4.5 V, I <sub>F</sub> = 5.0 mA	I <sub>OHH</sub>		0.5	100	μA
Output leakage current (V <sub>OUT</sub> > V <sub>CC</sub> )	V <sub>O</sub> = 15 V, V <sub>CC</sub> = 4.5 V, I <sub>F</sub> = 5.0 mA	I <sub>OHH</sub>		1.0	500	μA
Logic low supply current	V <sub>CC</sub> = 5.5 V, I <sub>F</sub> = 0	I <sub>CCL</sub>		3.7	6.0	mA
	V <sub>CC</sub> = 15 V, I <sub>F</sub> = 0	I <sub>CCL</sub>		4.1	6.5	mA
Logic high supply current	V <sub>CC</sub> = 5.5 V, I <sub>F</sub> = 5.0 mA	I <sub>CCH</sub>		3.4	4.0	mA
	V <sub>CC</sub> = 15 V, I <sub>F</sub> = 5.0 mA	I <sub>CCH</sub>		3.7	5.0	mA
Logic low short circuit output current (output short circuit time ≤ 10 ms)	V <sub>O</sub> = V <sub>CC</sub> = 5.5 V, I <sub>F</sub> = 0	I <sub>OSL</sub>	25			mA
	V <sub>O</sub> = V <sub>CC</sub> = 15 V, I <sub>F</sub> = 0	I <sub>OSL</sub>	40			mA
Logic high short circuit output current (output short circuit time ≤ 10 ms)	V <sub>CC</sub> = 5.5 V, V <sub>O</sub> = 0 V, I <sub>F</sub> = 5.0 mA	I <sub>OSH</sub>			- 10	mA
	V <sub>CC</sub> = 15 V, V <sub>O</sub> = 0 V, I <sub>F</sub> = 5.0 mA	I <sub>OSH</sub>			- 25	mA
Thermal resistance		R <sub>thja</sub>		300		K/W

### Coupler

-40 °C ≤ T<sub>amb</sub> ≤ 85 °C; 4.5 V ≤ V<sub>CC</sub> ≤ 15 V; 1.6 mA ≤ I<sub>Fon</sub> ≤ 5.0 mA; 2.0 ≤ V<sub>EH</sub> ≤ 15 V; 0 ≤ V<sub>EL</sub> ≤ 0.8 V; 0 mA ≤ I<sub>Foff</sub> ≤ 0.1 mA

Typical values: T<sub>amb</sub> = 25 °C; V<sub>CC</sub> = 5.0 V; I<sub>Fon</sub> = 3.0 mA unless otherwise specified.

Parameter	Test condition	Symbol	Min	Typ.	Max	Unit
Capacitance (input-output)	f = 1.0 MHz, pins 1-4 and 5-8 shorted together	C <sub>IO</sub>		0.6		pF
Isolation resistance	V <sub>IO</sub> = 500 V, T <sub>amb</sub> = 25 °C		10 <sup>12</sup>			Ω
	V <sub>IO</sub> = 500 V, T <sub>amb</sub> = 100 °C		10 <sup>11</sup>			Ω

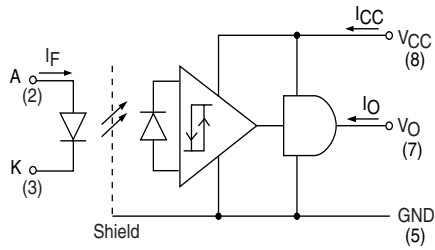

isfh6720\_00

## Switching Characteristics

$0\text{ }^{\circ}\text{C} \leq T_{\text{amb}} \leq 85\text{ }^{\circ}\text{C}$ ;  $4.5\text{ V} \leq V_{\text{CC}} \leq 15\text{ V}$ ;  $1.6\text{ mA} \leq I_{\text{Fon}} \leq 5.0\text{ mA}$ ;  $0\text{ mA} \leq I_{\text{Foff}} \leq 0.1\text{ mA}$   
 Typical values:  $T_{\text{amb}} = 25\text{ }^{\circ}\text{C}$ ;  $V_{\text{CC}} = 5.0\text{ V}$ ;  $I_{\text{Fon}} = 3.0\text{ mA}$  unless otherwise specified. <sup>(3)</sup>

Parameter	Test condition	Symbol	Min	Typ.	Max	Unit
Propagation delay time to logic low output level	Without peaking capacitor	$t_{\text{PHL}}$		120		ns
	With peaking capacitor	$t_{\text{PHL}}$		115	300	ns
Propagation delay time to logic high output level	Without peaking capacitor	$t_{\text{PLH}}$		125		ns
	With peaking capacitor	$t_{\text{PLH}}$		90	300	ns
Output rise time	10 % to 90 %	$t_r$		40		ns
Output fall time	90 % to 10 %	$t_f$		10		ns

<sup>(3)</sup> A 0.1  $\mu\text{F}$  bypass capacitor connected between pins 5 and 8 must be used

## Common Mode Transient Immunity

$T_{\text{amb}} = 25\text{ }^{\circ}$ ,  $V_{\text{CC}} = 5.0\text{ V}$ , <sup>(4)</sup>

Parameter	Test condition	Part	Symbol	Min	Typ.	Max	Unit
Logic High Common Mode Transient Immunity <sup>(4)</sup>	$ V_{\text{CM}}  = 50\text{ V}$ , $I_{\text{F}} = 1.6\text{ mA}$	SFH6720T	$ CM_{\text{H}} $	1000			$\text{V}/\mu\text{s}$
	$ V_{\text{CM}}  = 400\text{ V}$ , $I_{\text{F}} = 1.6\text{ mA}$	SFH6721T	$ CM_{\text{H}} $	2500			$\text{V}/\mu\text{s}$
Logic Low Common Mode Transient Immunity <sup>(4)</sup>	$ V_{\text{CM}}  = 50\text{ V}$ , $I_{\text{F}} = 0\text{ mA}$	SFH6720T	$ CM_{\text{L}} $	1000			$\text{V}/\mu\text{s}$
	$ V_{\text{CM}}  = 400\text{ V}$ , $I_{\text{F}} = 0\text{ mA}$	SFH6721T	$ CM_{\text{L}} $	2500			$\text{V}/\mu\text{s}$

<sup>(4)</sup>  $CM_{\text{H}}$  is the maximum slew rate of a common mode voltage  $V_{\text{CM}}$  at which the output voltage remains at logic high level ( $V_{\text{O}} > 2.0\text{ V}$ )

$CM_{\text{L}}$  is the maximum slew rate of a common mode voltage  $V_{\text{CM}}$  at which the output voltage remains at logic low level ( $V_{\text{O}} < 0.8\text{ V}$ )

## Typical Characteristics ( $T_{amb} = 25\text{ }^{\circ}\text{C}$ unless otherwise specified)

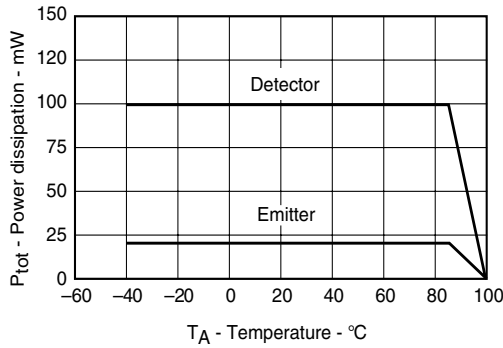

isfh6720\_01

Fig. 1 Permissible Total Power Dissipation vs. Temperature

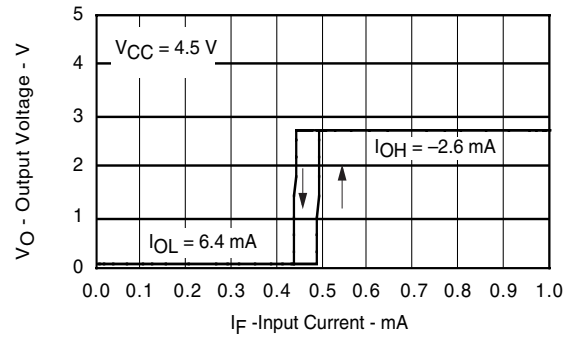

isfh6720\_04

Fig. 4 Typical Output Voltage vs. Forward Input Current

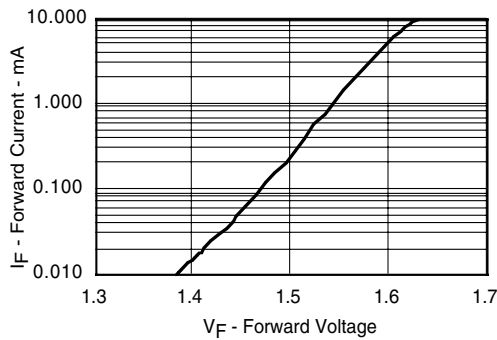

isfh6720\_02

Fig. 2 Typical Input Diode Forward Current vs. Forward Voltage

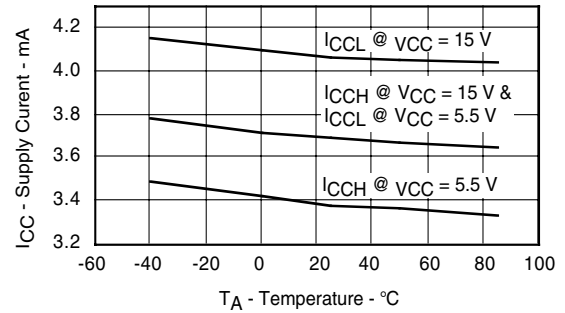

isfh6720\_05

Fig. 5 Typical Supply Current vs. Temperature

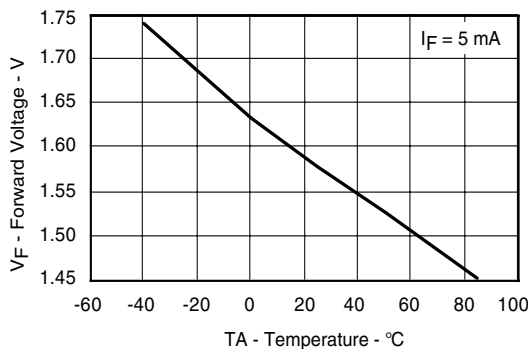

isfh6720\_03

Fig. 3 Typical Forward Input Voltage vs. Temperature

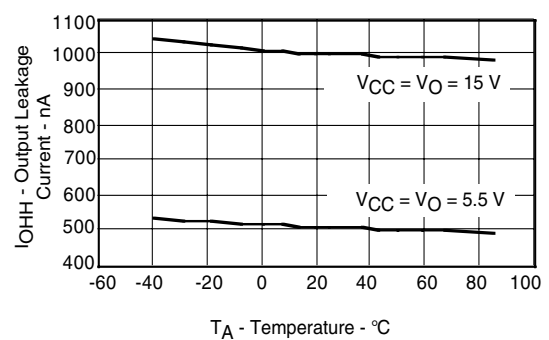

isfh6720\_06

Fig. 6 Typical Output Leakage Current vs. Temperature

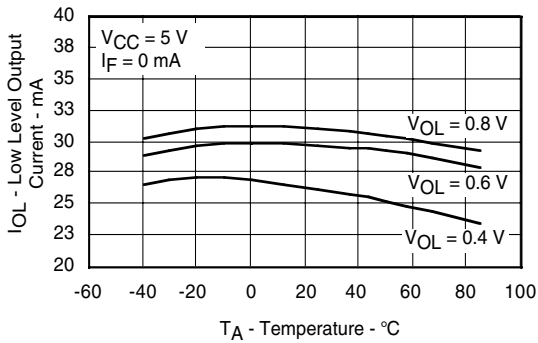

isfh6720\_07

Fig. 7 Typical Low Level Output Current vs. Temperature

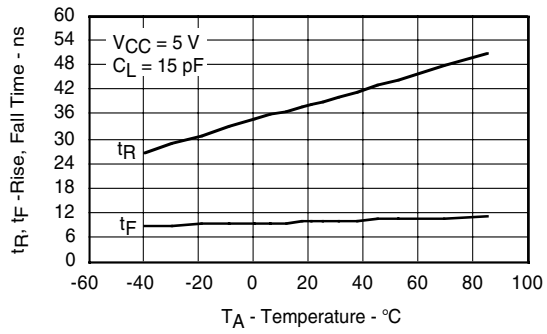

isfh6720\_10

Fig. 10 Typical Rise, Fall Time vs. Temperature

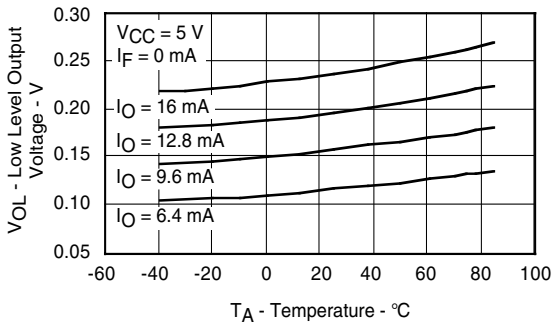

isfh6720\_08

Fig. 8 Typical Low Level Output Voltage vs. Temperature

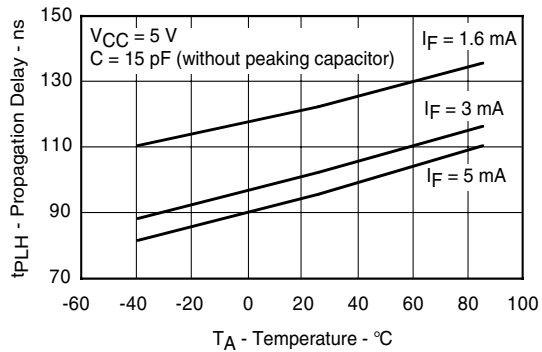

isfh6720\_11

Fig. 11 Typical Propagation Delays to Logic High vs. Temperature

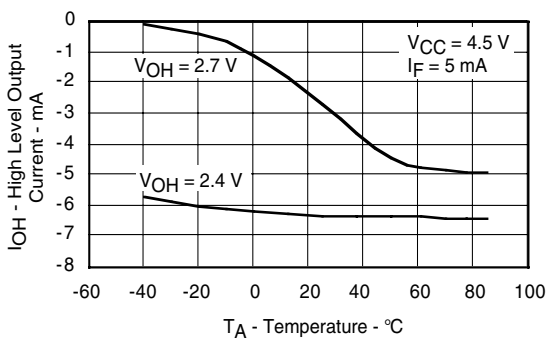

isfh6720\_09

Fig. 9 Typical High Level Output Current vs. Temperature

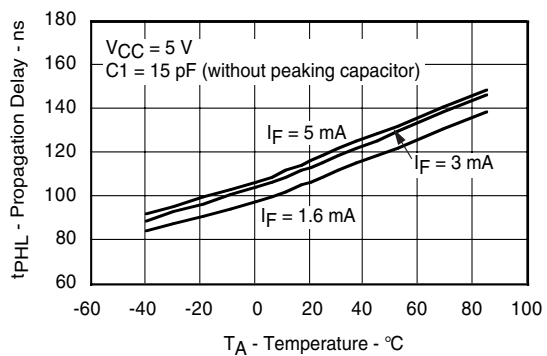

isfh6720\_12

Fig. 12 Typical Propagation Delays to Logic Low vs. Temperature

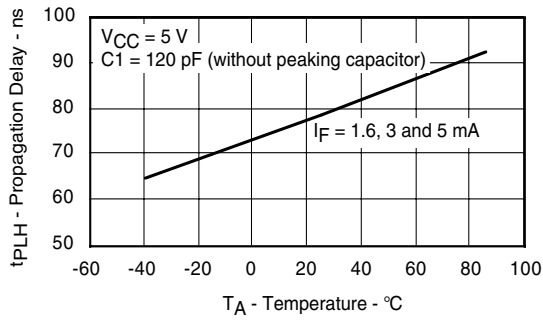

isfh6720\_13

Fig. 13 Typical Propagation Delays to Logic High vs. Temperature

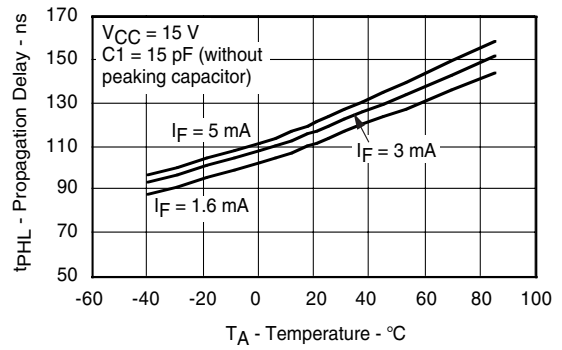

isfh6720\_16

Fig. 16 Typical Propagation Delays to Logic Low vs. Temperature

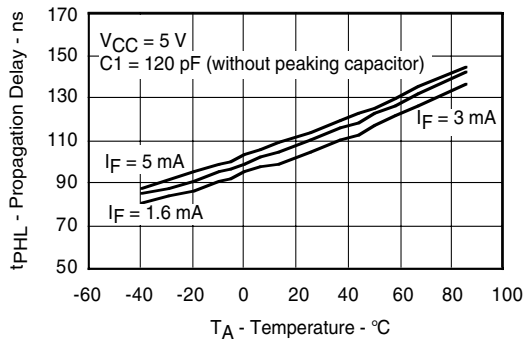

isfh6720\_14

Fig. 14 Typical Propagation Delays to Logic Low vs. Temperature

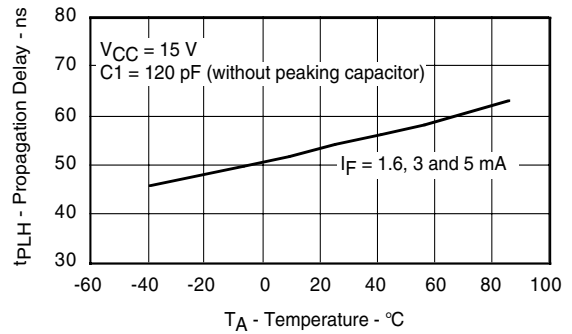

isfh6720\_17

Fig. 17 Typical Propagation Delays to Logic High vs. Temperature

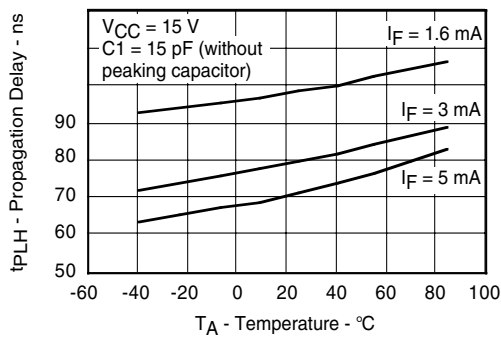

isfh6720\_15

Fig. 15 Typical Propagation Delays to Logic High vs. Temperature

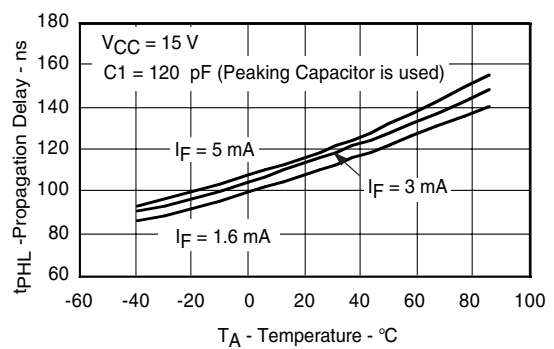

isfh6720\_18

Fig. 18 Typical Propagation Delays to Logic Low vs. Temperature

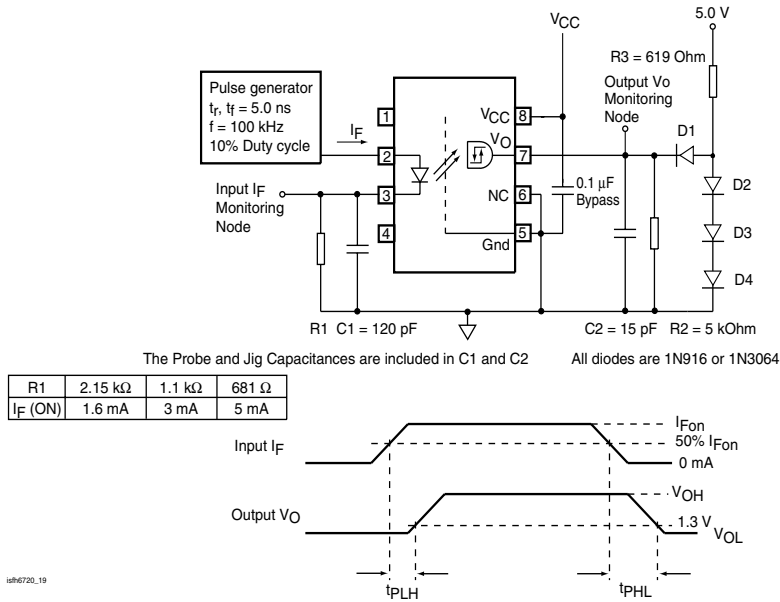

Fig. 19 Test Circuit for t<sub>PLH</sub>, t<sub>PHL</sub>, t<sub>r</sub> and t<sub>f</sub>

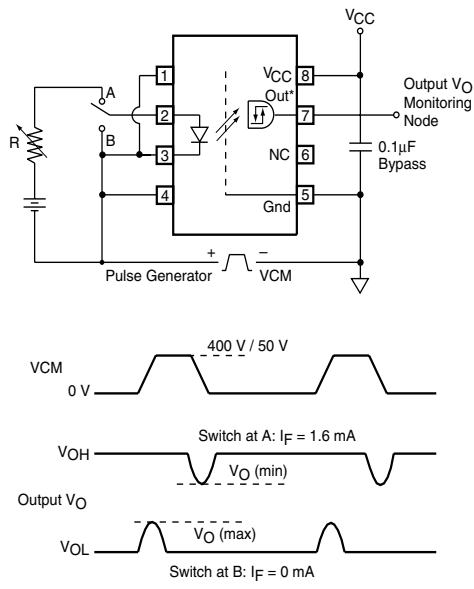
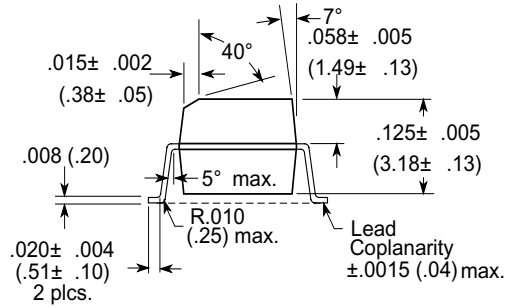
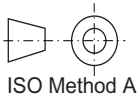
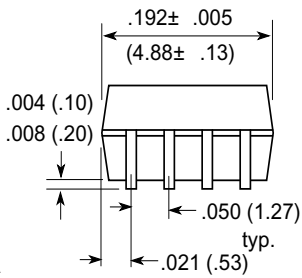
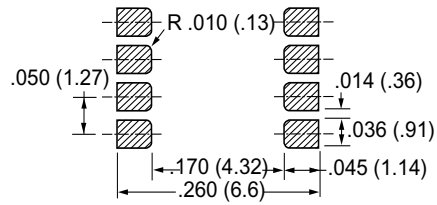
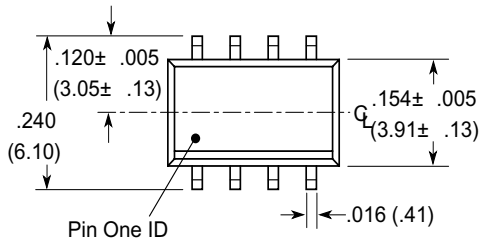

Fig. 20 Test Circuit for Common Mode Transient Immunity and Typical Waveforms

## Package Dimensions in Inches (mm)



i178003

### Ozone Depleting Substances Policy Statement

It is the policy of **Vishay Semiconductor GmbH** to

1. Meet all present and future national and international statutory requirements.
2. Regularly and continuously improve the performance of our products, processes, distribution and operating systems with respect to their impact on the health and safety of our employees and the public, as well as their impact on the environment.

It is particular concern to control or eliminate releases of those substances into the atmosphere which are known as ozone depleting substances (ODSs).

The Montreal Protocol (1987) and its London Amendments (1990) intend to severely restrict the use of ODSs and forbid their use within the next ten years. Various national and international initiatives are pressing for an earlier ban on these substances.

**Vishay Semiconductor GmbH** has been able to use its policy of continuous improvements to eliminate the use of ODSs listed in the following documents.

1. Annex A, B and list of transitional substances of the Montreal Protocol and the London Amendments respectively
2. Class I and II ozone depleting substances in the Clean Air Act Amendments of 1990 by the Environmental Protection Agency (EPA) in the USA
3. Council Decision 88/540/EEC and 91/690/EEC Annex A, B and C (transitional substances) respectively.

**Vishay Semiconductor GmbH** can certify that our semiconductors are not manufactured with ozone depleting substances and do not contain such substances.

**We reserve the right to make changes to improve technical design  
and may do so without further notice.**

Parameters can vary in different applications. All operating parameters must be validated for each customer application by the customer. Should the buyer use Vishay Semiconductors products for any unintended or unauthorized application, the buyer shall indemnify Vishay Semiconductors against all claims, costs, damages, and expenses, arising out of, directly or indirectly, any claim of personal damage, injury or death associated with such unintended or unauthorized use.

Vishay Semiconductor GmbH, P.O.B. 3535, D-74025 Heilbronn, Germany  
Telephone: 49 (0)7131 67 2831, Fax number: 49 (0)7131 67 2423