

AC Input Phototransistor Optocoupler Miniflat SOP Package

Features

- SOP (Small Outline Package)
- Isolation Test Voltage, 3750 V_{RMS} (1.0 s)
- High Collector-Emitter Breakdown Voltage, V_{CEO} = 70 V
- Bidirectional AC Input
- Low Saturation Voltage
- Fast Switching Times
- Field-Effect Stable by TRIOS (TRansparent IO n Shield)
- Temperature Stable
- Low Coupling Capacitance
- End-Stackable, .100" (2.54 mm) Spacing
- Underwriters Lab File #52744

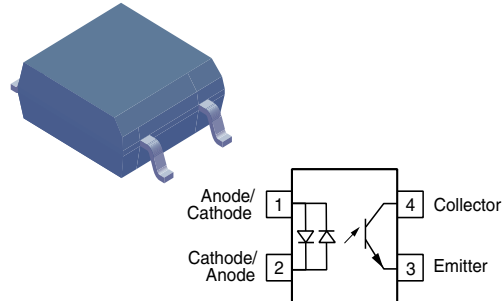

1179066

100 mil lead pitch miniflat package. It features a high current transfer ratio, low coupling capacitance, and high isolation voltage.

The coupling devices are designed for signal transmission between two electrically separated circuits.

The SFH691AT is available only on tape and reel.

Applications

High density mounting or space sensitive PCBs
PLCs
Telecommunications

Description

The SFH691AT has a GaAs infrared emitting diode emitter, which is optically coupled to silicon planar phototransistor detector, and is incorporated in a 4 pin

Order Information

Part	Type differentiation
SFH691AT	CTR 50-300 %

For additional order information see Option Section

Absolute Maximum Ratings

T_{amb} = 25 °C, unless otherwise specified

Emitter

Parameter	Test condition	Symbol	Value	Unit
DC Forward current		I _F	50	mA
Surge Forward current	t _p ≤ 10 μs	I _{FSM}	2.5	A
Total power dissipation		P _{Diss}	80	mW

Detector

Parameter	Test condition	Symbol	Value	Unit
Collector-emitter voltage		V _{CE}	70	V
Emitter-collector voltage		V _{EC}	7.0	V
Collector current		I _C	50	mA
	t _p ≤ 1.0 ms	I _C	100	mA
Total power dissipation		P _{Diss}	150	mW

Coupler

Parameter	Test condition	Symbol	Value	Unit
Isolation test voltage between emitter and detector, (1.0 s)		V_{IO}	3750	V_{RMS}
Creepage			≥ 5.0	mm
Clearance			≥ 5.5	mm
Comparative tracking index per DIN IEC 112/VDEO 303, part 1			≥ 175	
Isolation resistance	$V_{IO} = 500\text{ V}, T_{amb} = 25\text{ }^{\circ}\text{C}$	R_{IO}	$\geq 10^{12}$	Ω
	$V_{IO} = 500\text{ V}, T_{amb} = 100\text{ }^{\circ}\text{C}$	R_{IO}	$\geq 10^{11}$	Ω
Storage temperature range		T_{stg}	- 55 to + 150	$^{\circ}\text{C}$
Ambient temperature range		T_{amb}	- 55 to + 100	$^{\circ}\text{C}$
Junction temperature		T_j	100	$^{\circ}\text{C}$
Soldering temperature (max. 10 s. dip soldering distance to seating plane $\geq 1.5\text{ mm}$)		T_{sd}	260	$^{\circ}\text{C}$

Electrical Characteristics

$T_{amb} = 25\text{ }^{\circ}\text{C}$, unless otherwise specified

Emitter

Parameter	Test condition	Symbol	Typ.	Max	Unit
Forward voltage	$I_F = \pm 5.0\text{ mA}$	V_F	1.15	1.4	V
Capacitance	$V_R = 0\text{ V}, f = 1.0\text{ MHz}$	C_O	29		pF
Thermal resistance		R_{thJA}	750		K/W

Detector

Parameter	Test condition	Symbol	Typ.	Max	Unit
Collector-emitter leakage current	$V_{CE} = 20\text{ V}$	I_{CEO}		100	nA
Capacitance	$V_{CE} = 5.0\text{ V}, f = 1.0\text{ MHz}$	C_{CE}	5.0		pF
Thermal resistance		R_{thJA}	500		K/W

Coupler

Parameter	Test condition	Symbol	Typ.	Max	Unit
Collector-emitter saturation voltage	$I_F = 10\text{ mA}, I_C = 2.0\text{ mA}$	V_{CEsat}	0.1	0.3	V
Coupling capacitance	$f = 1.0\text{ MHz}$	C_C	0.4		pF

Current Transfer Ratio

Parameter	Test condition	Symbol	Min	Typ.	Max	Unit
Current transfer ratio	$I_F = \pm 5.0\text{ mA}, V_{CE} = 5.0\text{ V}$	CTR	50	120	300	%
CTR1/CTR2	$CTR1 = I_{C1}/I_{F1}, CTR2 = I_{C2}/I_{F2}$		0.3		3.0	

Switching Characteristics

Parameter	Test condition	Symbol	Max	Unit
Rise time	$I_F = 5.0 \text{ mA}$, $V_{CC} = 5.0 \text{ V}$, $R_L = 100 \Omega$	t_r	3.0	μs
Fall time	$I_F = 5.0 \text{ mA}$, $V_{CC} = 5.0 \text{ V}$, $R_L = 100 \Omega$	t_f	4.0	μs
Turn-on time	$I_F = 5.0 \text{ mA}$, $V_{CC} = 5.0 \text{ V}$, $R_L = 100 \Omega$	t_{on}	5.0	μs
Turn-off time	$I_F = 5.0 \text{ mA}$, $V_{CC} = 5.0 \text{ V}$, $R_L = 100 \Omega$	t_{off}	3.0	μs

Typical Characteristics ($T_{amb} = 25 \text{ }^\circ\text{C}$ unless otherwise specified)

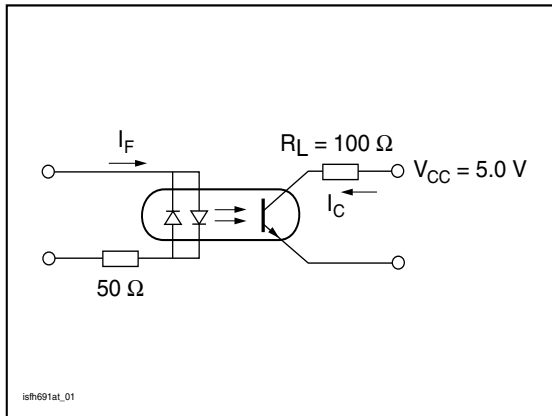
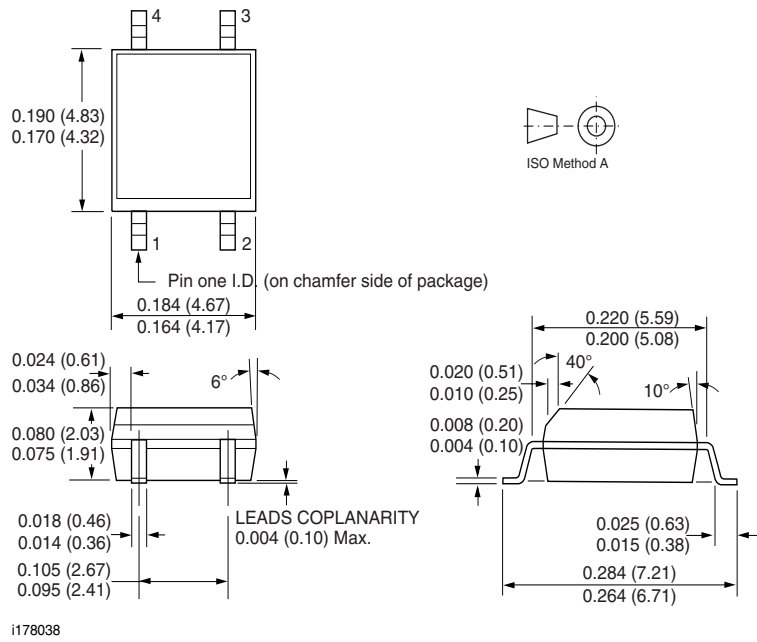

Figure 1. Linear Operation (without saturation)

Package Dimensions in Inches (mm)



Ozone Depleting Substances Policy Statement

It is the policy of **Vishay Semiconductor GmbH** to

1. Meet all present and future national and international statutory requirements.
2. Regularly and continuously improve the performance of our products, processes, distribution and operating systems with respect to their impact on the health and safety of our employees and the public, as well as their impact on the environment.

It is particular concern to control or eliminate releases of those substances into the atmosphere which are known as ozone depleting substances (ODSs).

The Montreal Protocol (1987) and its London Amendments (1990) intend to severely restrict the use of ODSs and forbid their use within the next ten years. Various national and international initiatives are pressing for an earlier ban on these substances.

Vishay Semiconductor GmbH has been able to use its policy of continuous improvements to eliminate the use of ODSs listed in the following documents.

1. Annex A, B and list of transitional substances of the Montreal Protocol and the London Amendments respectively
2. Class I and II ozone depleting substances in the Clean Air Act Amendments of 1990 by the Environmental Protection Agency (EPA) in the USA
3. Council Decision 88/540/EEC and 91/690/EEC Annex A, B and C (transitional substances) respectively.

Vishay Semiconductor GmbH can certify that our semiconductors are not manufactured with ozone depleting substances and do not contain such substances.

**We reserve the right to make changes to improve technical design
and may do so without further notice.**

Parameters can vary in different applications. All operating parameters must be validated for each customer application by the customer. Should the buyer use Vishay Semiconductors products for any unintended or unauthorized application, the buyer shall indemnify Vishay Semiconductors against all claims, costs, damages, and expenses, arising out of, directly or indirectly, any claim of personal damage, injury or death associated with such unintended or unauthorized use.

Vishay Semiconductor GmbH, P.O.B. 3535, D-74025 Heilbronn, Germany
Telephone: 49 (0)7131 67 2831, Fax number: 49 (0)7131 67 2423