

POWER MANAGEMENT

PRELIMINARY

Description

The SC2982 is a 50mA ultra low dropout linear regulator with a built in CMOS/TTL logic level enable switch. It is designed specifically for battery powered applications where low quiescent current and low dropout are critical for battery longevity.

The SC2982 uses a Semtech proprietary internal PNP device for the pass element, providing a low dropout voltage of 100mV at a load of 50mA, while maintaining a ground pin current of 600µA.

The output noise is reduced by placing a 10nF capacitor on pin 4 (bypass).

Each device contains a bandgap reference, error amplifier, PNP pass element, thermal and current limiting circuitry and resistor divider network for setting output voltage.

The SC2982 is packaged in a 5 pin SOT-23 surface mount package for a very small footprint and requires only a 1µF capacitor on the output for a minimum number of external components.

Features

- ◆ Ultra low dropout voltage - 100mV @ 50mA
- ◆ Guaranteed 50mA output current
- ◆ Low ground pin current at all loads
- ◆ <1µA quiescent current in shutdown
- ◆ Wide input supply voltage range 2.5V to 16V
- ◆ Wide output voltage range
- ◆ Excellent line regulation
- ◆ Industrial temperature range
- ◆ Surface mount packaging (5 pin SOT-23)

Applications

- ◆ Battery Powered Systems
- ◆ Cellular Telephones
- ◆ Cordless Telephones
- ◆ Pagers
- ◆ Personal Digital Assistants
- ◆ Portable Instrumentation
- ◆ Cameras
- ◆ Portable Consumer Equipment
- ◆ PCMCIA Cards

Typical Application Circuit

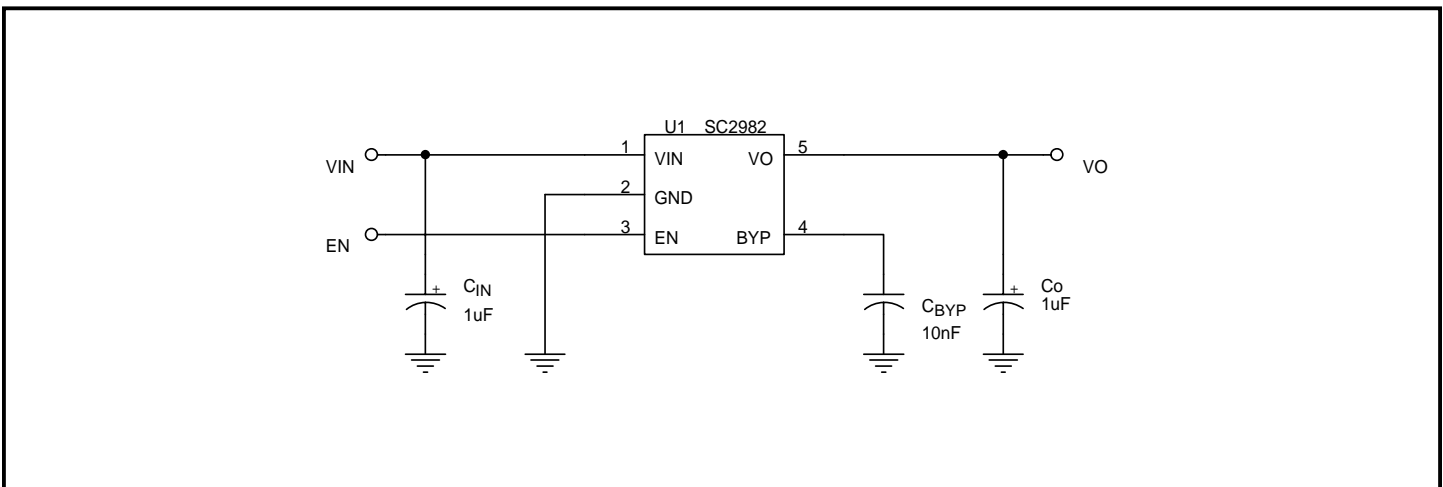

Notes:

- (1) C_{IN} is needed if the device is far from the supply's filter capacitors, or for operation from a battery. A value of 1µF or greater should be used. C_{IN} may be a tantalum or aluminum electrolytic capacitor.
- (2) C_O should be a 1µF or greater tantalum or aluminum electrolytic capacitor. Larger value capacitors will improve the overall transient response. Due to their very low ESR, ceramic capacitors should not be used.
- (3) C_{BYP} should be placed as close as possible to pin 4 and ground. A 10nF ceramic capacitor is recommended.
- (4) EN should be tied to VIN if the shutdown feature is not required. Maximum EN voltage = VIN.

POWER MANAGEMENT
PRELIMINARY
Absolute Maximum Ratings

Parameter	Symbol	Maximum	Units
Input Supply Voltage	V _{IN}	-0.3 to +20	V
Power Dissipation	P _D	Internally Limited	W
Thermal Resistance Junction to Ambient	θ _{JA}	256	°C/W
Thermal Resistance Junction to Case	θ _{JC}	81	°C/W
Operating Ambient Temperature Range	T _A	-40 to +85	°C
Operating Junction Temperature Range	T _J	-40 to +125	°C
Storage Temperature Range	T _{STG}	-65 to +150	°C
Lead Temperature (Soldering) 10 Sec	T _{LEAD}	300	°C
ESD Rating (Human Body Model)	V _{ESD}	2	kV

Electrical Characteristics

Unless specified: V_{IN} = V_{O(NOM)} + 1V, I_O = 100μA, C_O = 1μF, V_{EN} ≥ 1.8V. Values in **bold** apply over the full operating temperature range.

Parameter	Symbol	Test Conditions	Min	Typ	Max	Units
Supply Voltage Range	V _{IN}		2.5		16	V
Output Voltage	V _O		-1		+1	%
			-3		+3	
Output Voltage Temperature Coefficient	TC			40		ppm/°C
Line Regulation	REG _(LINE)	V _{IN} = (V _{O(NOM)} + 1V) to 16V		0.06	0.12	%V
					0.15	
Load Regulation	REG _(LOAD)	I _O = 0.1mA to 50mA		0.001	0.004	%/mA
					0.007	
Dropout Voltage ⁽¹⁾	V _D	I _O = 100μA		5	10	mV
					25	
		I _O = 50mA		100	150	mV
					200	
Ground Pin Current	I _{GND}	I _O = 100μA		80	125	μA
					150	
		I _O = 50mA		600	1000	μA
					1500	
	V _{EN} < 0.4V (shutdown)		0.01	5	μA	

POWER MANAGEMENT
PRELIMINARY
Electrical Characteristics

 Unless specified: $V_{IN} = V_{O(NOM)} + 1V$, $I_o = 100\mu A$, $C_o = 1\mu F$, $V_{EN} \geq 1.8V$. Values in **bold** apply over the full operating temperature range.

Parameter	Symbol	Test Conditions	Min	Typ	Max	Units
Current Limit ⁽²⁾	I_{LIM}	$VO > (VO_{(NOM)} - 5\%)$	200			mA
Ripple Rejection Ratio	PSRR	$I_o = 100\mu A$, $f = 100Hz$, $C_{BYP} = 10nF$, $C_o = 10\mu F$		50		db
Thermal Regulation	$\frac{\Delta V_o(\%)}{P_D}$			0.05		%/W
RMS Output Noise	e_{no}	$B_W = 300Hz$ to $50kHz$, $I_o = 1mA$, $C_{BYP} = 10nF$, $C_o = 10\mu F$		30		μV_{rms}
Enable Input Voltage	V_{EN}	Low = O/P OFF			0.4	V
		High = O/P ON	1.8			V
Enable Input Current	I_{EN}	$V_{EN} \leq 0.4V$		-0.01	-1	μA
		$V_{EN} \geq 1.8V$		5	10	μA
					20	

Notes:

(1) Defined as the input to output differential at which the output voltage drops 100mV below the value measured at a differential of 1V.

(2) As the load resistance further decreases, the SC2982 folds back the output current to approximately 150mA at $V_o = 0V$.

POWER MANAGEMENT

PRELIMINARY

Pin Configuration

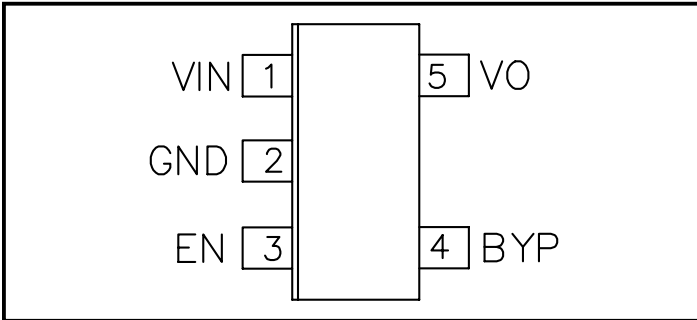

Ordering Information

Device	Package
SC2982CSK-X.XTR ⁽¹⁾⁽²⁾	5 pin SOT-23

Notes:

(1) Where -X.X denotes voltage options. Available voltages are: 1.8V, 2.5V, 2.8V, 3.0V, 3.3V, 3.6V, 3.8V, 4.0V and 5.0V.

(2) Only available in tape and reel packaging. A reel contains 3000 devices.

Block Diagram

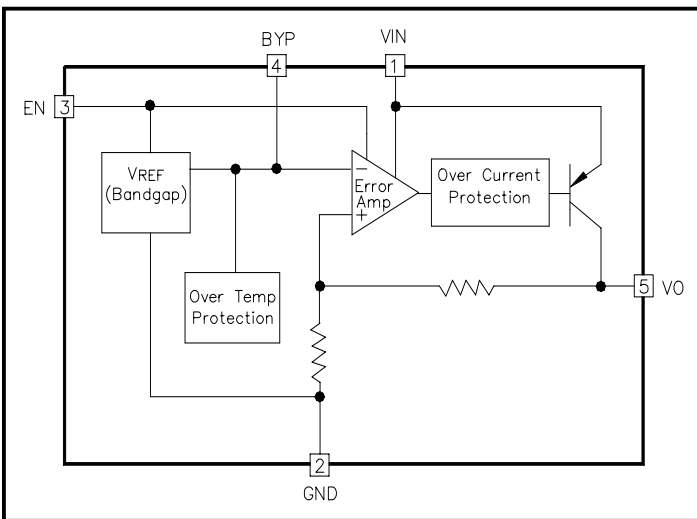

Pin Descriptions

Pin	Pin Name	Pin Function
1	VIN	Supply voltage input.
2	GND	Ground.
3	EN	Active high enable input. Connect to VIN if not being used.
4	BYP	Reference bypass. Connect a 10nF capacitor between this pin and GND to reduce output noise
5	VO	Voltage output.

Outline Drawing - SOT-23-5

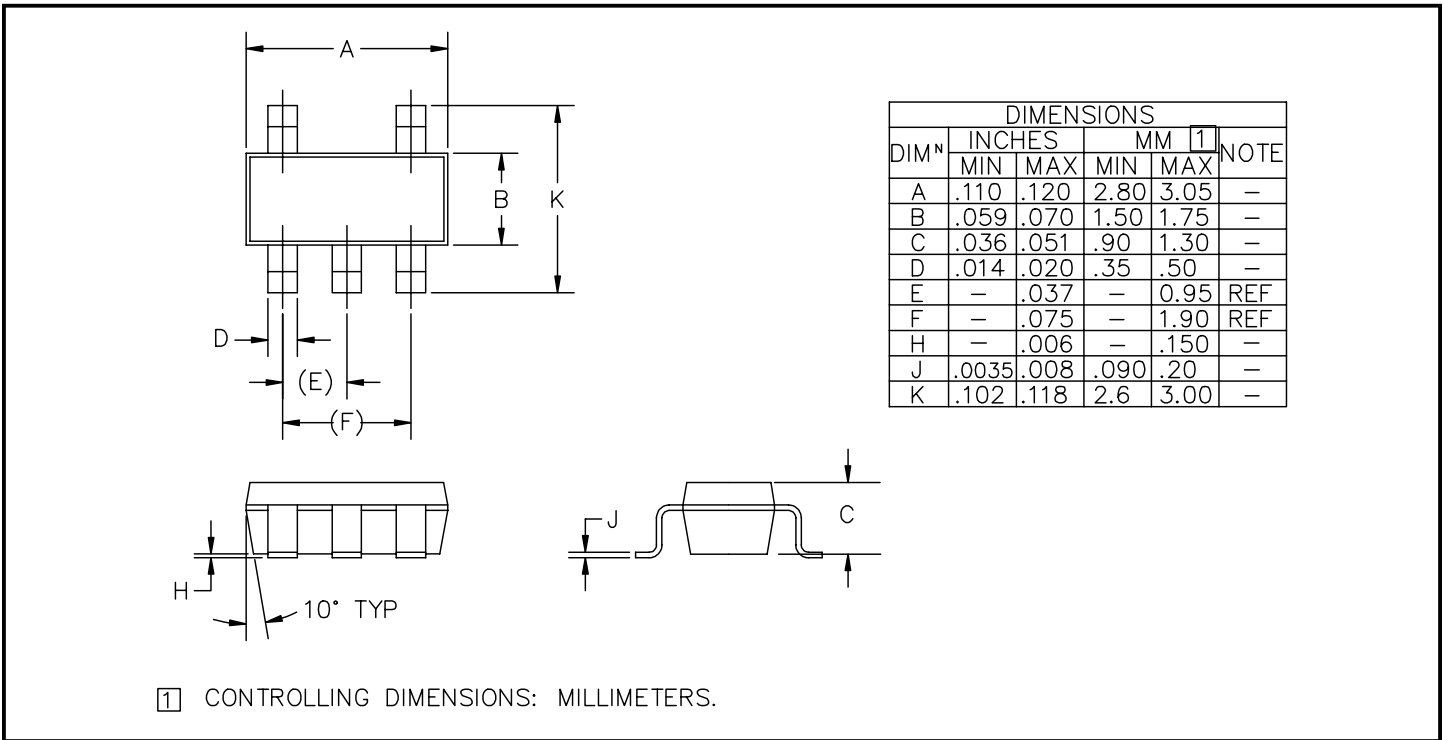

Land Pattern - SOT-23-5

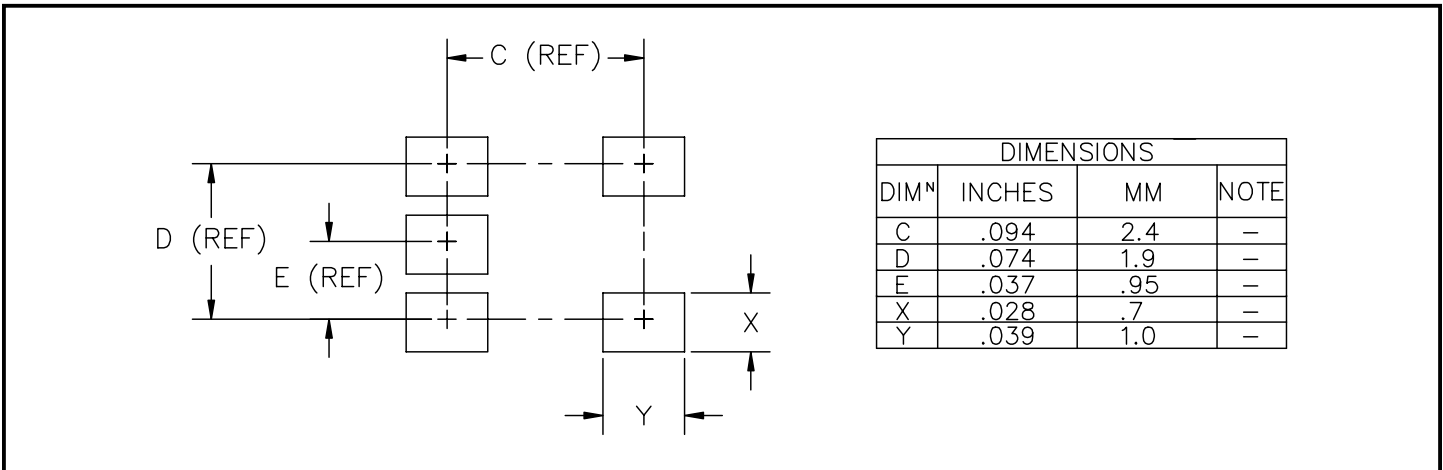

Contact Information

Semtech Corporation
 Power Management Products Division
 652 Mitchell Rd., Newbury Park, CA 91320
 Phone: (805)498-2111 FAX (805)498-3804