

2SC4995

Silicon NPN Epitaxial

REJ03G0194-0300Z
(Previous ADE-208-013A (Z))
Rev.3.00
Apr.05.2004

Application

VHF / UHF wide band amplifier

Features

- High gain bandwidth product
 $f_T = 11 \text{ GHz Typ.}$
- High gain, low noise figure
 $PG = 16.5 \text{ dB Typ. , } NF = 1.1 \text{ dB Typ. at } f = 900 \text{ MHz}$

Outline

CMPAK-4

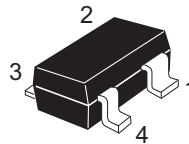

1. Collector
2. Emitter
3. Base
4. Emitter

Note: Marking is "YD-".

Attention: This device is very sensitive to electro static discharge.
It is recommended to adopt appropriate cautions when handling this transistor.

Absolute Maximum Ratings

(Ta = 25°C)

Item	Symbol	Ratings	Unit
Collector to base voltage	V _{CBO}	15	V
Collector to emitter voltage	V _{CEO}	8	V
Emitter to base voltage	V _{EBO}	1.5	V
Collector current	I _C	50	mA
Collector power dissipation	P _C	100	mW
Junction temperature	T _j	150	°C
Storage temperature	T _{stg}	-55 to +150	°C

Electrical Characteristics

(Ta = 25°C)

Item	Symbol	Min	Typ	Max	Unit	Test Conditions
Collector to base breakdown voltage	V _{(BR)CBO}	15	—	—	V	I _C = 10 μA, I _E = 0
Collector cutoff current	I _{CBO}	—	—	10	μA	V _{CB} = 12 V, I _E = 0
	I _{CEO}	—	—	1	mA	V _{CE} = 8 V, R _{BE} = ∞
Emitter cutoff current	I _{EBO}	—	—	10	μA	V _{EB} = 1.5 V, I _C = 0
DC current transfer ratio	h _{FE}	50	120	250		V _{CE} = 5 V, I _C = 20 mA
Collector output capacitance	C _{ob}	—	0.55	1.1	pF	V _{CB} = 5 V, I _E = 0, f = 1 MHz
Gain bandwidth product	f _T	8.0	11.0	—	GHz	V _{CE} = 5 V, I _C = 20 mA
S21 Parameter	S21	—	16	—	dB	V _{CE} = 5 V, I _C = 20 mA, f = 1000 MHz
Power gain	PG	13.5	16.5	—	dB	V _{CE} = 5 V, I _C = 20 mA, f = 900 MHz
Noise figure	NF	—	1.1	2.0	dB	V _{CE} = 5 V, I _C = 5 mA, f = 900 MHz

Main Characteristics

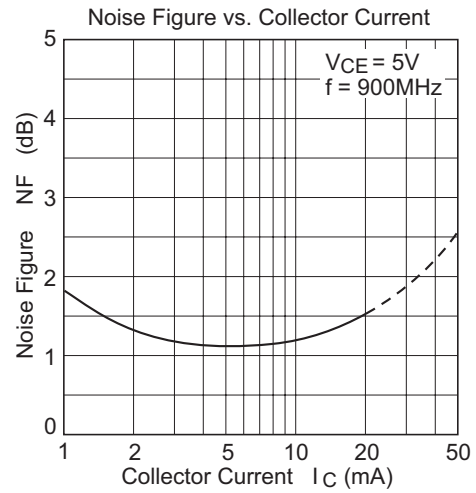
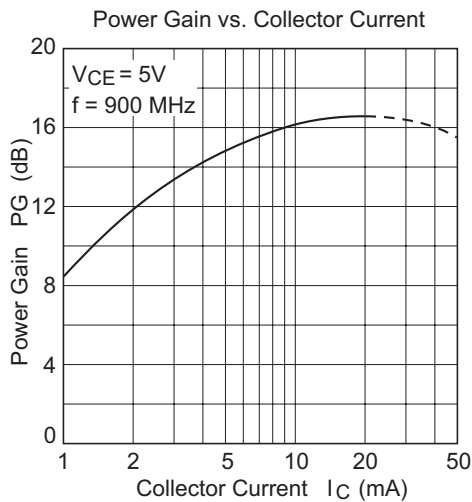
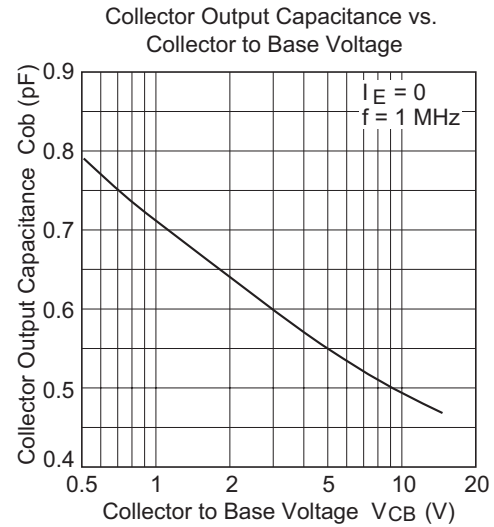
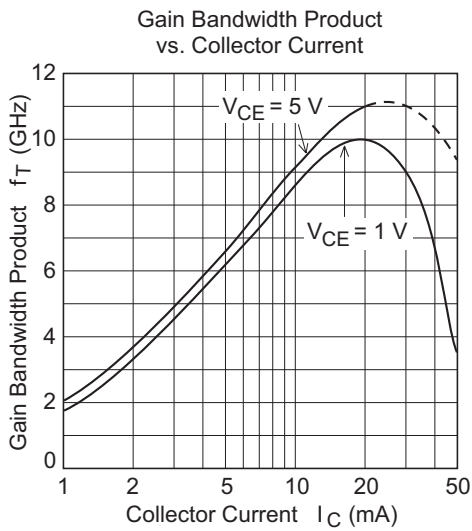
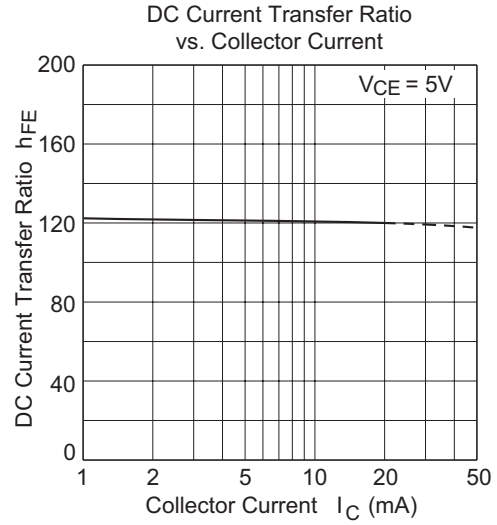
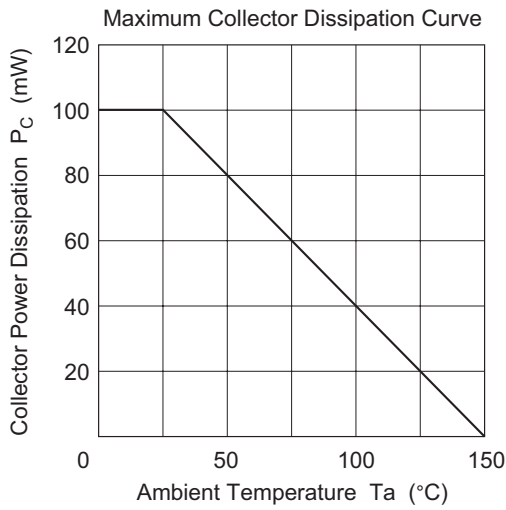

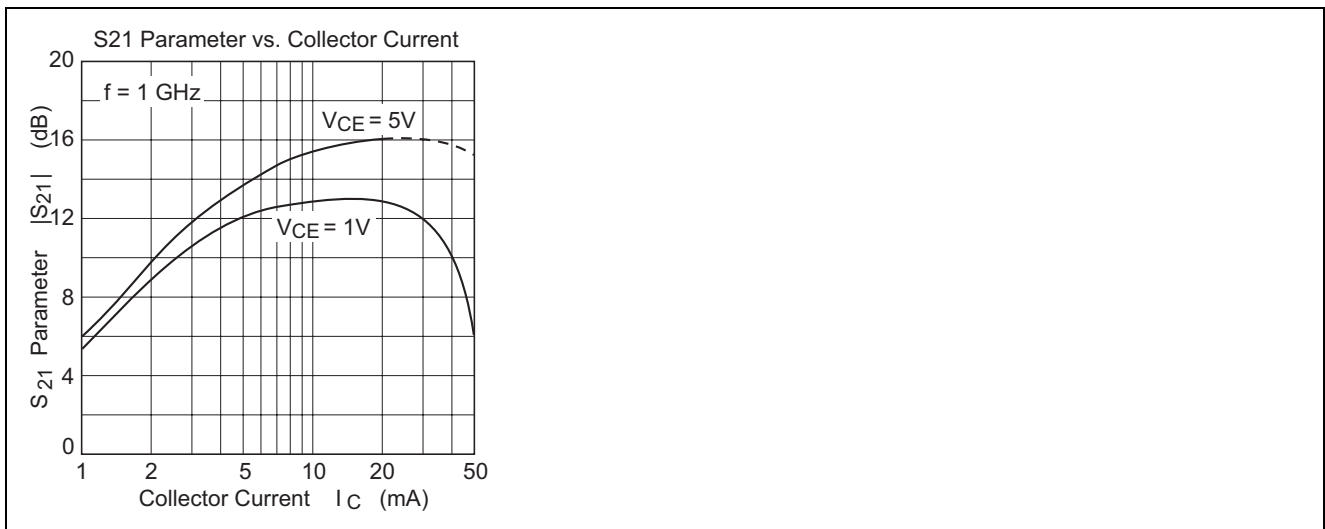

S11 Parameter vs. Frequency

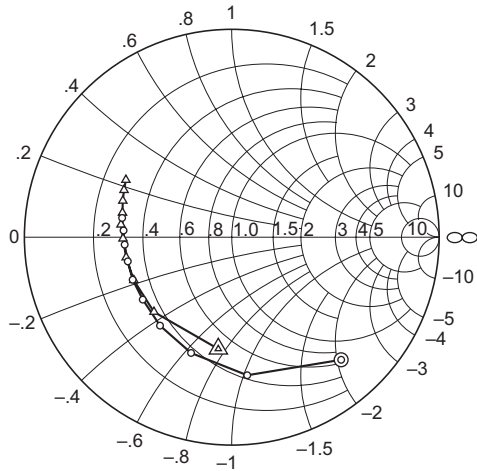

Condition: $V_{CE} = 5\text{ V}$, $Z_o = 50\ \Omega$
 200 to 2000 MHz (200 MHz step)
 ○ — ○ ($I_C = 5\text{ mA}$)
 △ — △ ($I_C = 20\text{ mA}$)

S21 Parameter vs. Frequency

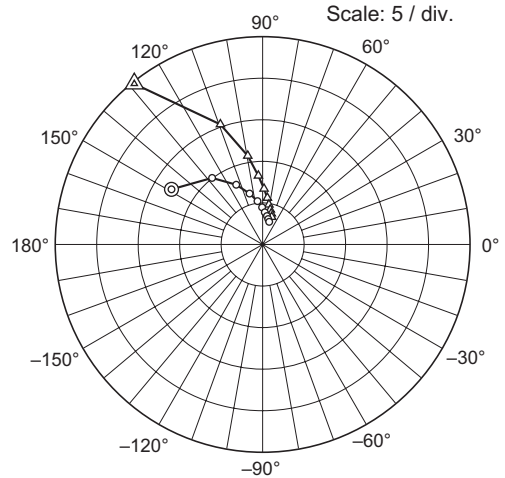

Condition: $V_{CE} = 5\text{ V}$, $Z_o = 50\ \Omega$
 200 to 2000 MHz (200 MHz step)
 ○ — ○ ($I_C = 5\text{ mA}$)
 △ — △ ($I_C = 20\text{ mA}$)

S12 Parameter vs. Frequency

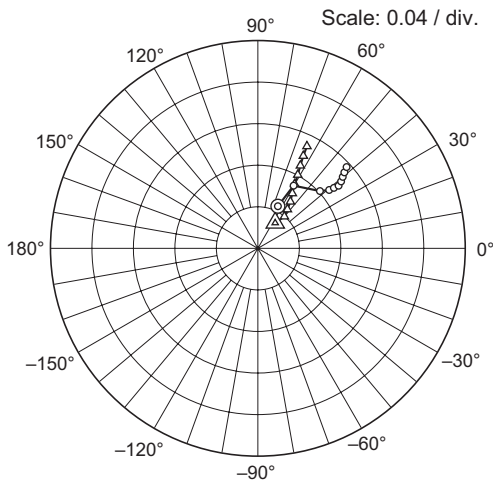

Condition: $V_{CE} = 5\text{ V}$, $Z_o = 50\ \Omega$
 200 to 2000 MHz (200 MHz step)
 ○ — ○ ($I_C = 5\text{ mA}$)
 △ — △ ($I_C = 20\text{ mA}$)

S22 Parameter vs. Frequency

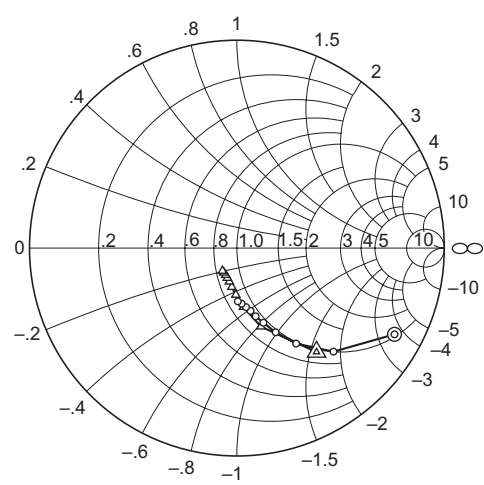

Condition: $V_{CE} = 5\text{ V}$, $Z_o = 50\ \Omega$
 200 to 2000 MHz (200 MHz step)
 ○ — ○ ($I_C = 5\text{ mA}$)
 △ — △ ($I_C = 20\text{ mA}$)

S11 Parameter vs. Frequency

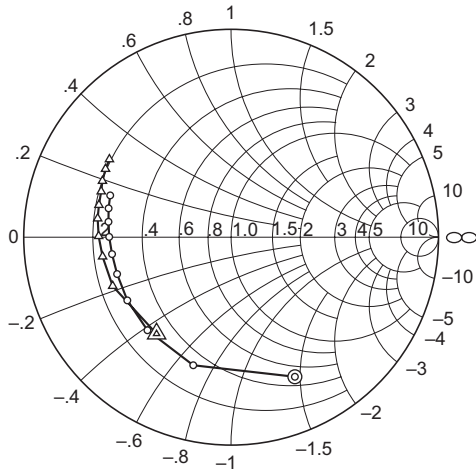

Condition: $V_{CE} = 1\text{ V}$, $Z_o = 50\ \Omega$
 200 to 2000 MHz (200 MHz step)
 ○ — ○ ($I_C = 5\text{ mA}$)
 △ — △ ($I_C = 20\text{ mA}$)

S21 Parameter vs. Frequency

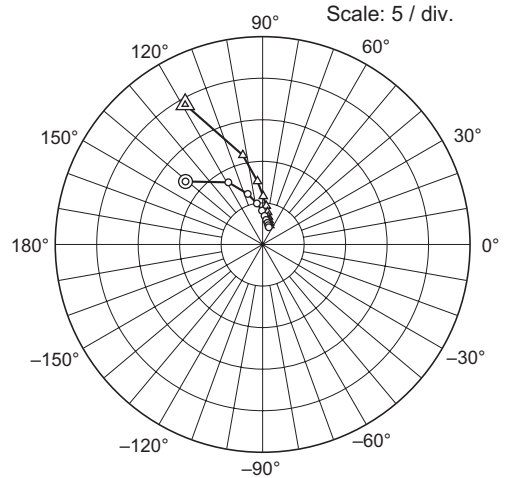

Condition: $V_{CE} = 1\text{ V}$, $Z_o = 50\ \Omega$
 200 to 2000 MHz (200 MHz step)
 ○ — ○ ($I_C = 5\text{ mA}$)
 △ — △ ($I_C = 20\text{ mA}$)

S12 Parameter vs. Frequency

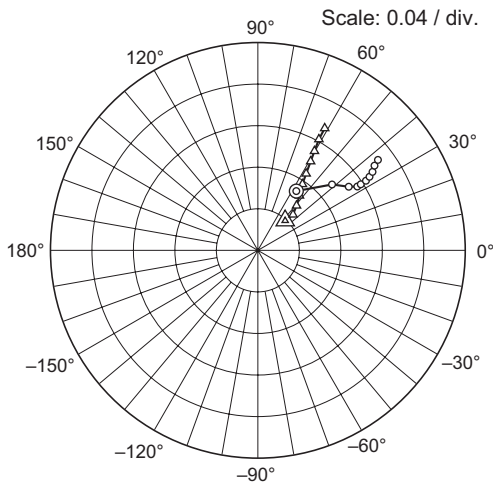

Condition: $V_{CE} = 1\text{ V}$, $Z_o = 50\ \Omega$
 200 to 2000 MHz (200 MHz step)
 ○ — ○ ($I_C = 5\text{ mA}$)
 △ — △ ($I_C = 20\text{ mA}$)

S22 Parameter vs. Frequency

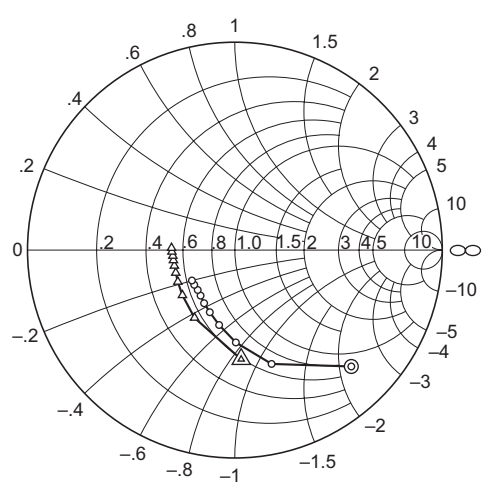

Condition: $V_{CE} = 1\text{ V}$, $Z_o = 50\ \Omega$
 200 to 2000 MHz (200 MHz step)
 ○ — ○ ($I_C = 5\text{ mA}$)
 △ — △ ($I_C = 20\text{ mA}$)

S Parameter

 $(V_{CE} = 5 \text{ V}, I_C = 5 \text{ mA}, Z_O = 50 \Omega)$

Freq. (MHz)	S11		S21		S12		S22	
	MAG.	ANG.	MAG.	ANG.	MAG.	ANG.	MAG.	ANG.
200	0.781	-48.2	12.84	148.8	0.0449	64.6	0.866	-28.6
400	0.669	-83.6	10.04	127.3	0.0695	50.3	0.682	-46.9
600	0.591	-109.4	7.84	113.9	0.0815	42.6	0.541	-58.1
800	0.549	-129.1	6.30	104.4	0.0889	39.2	0.446	-65.2
1000	0.524	-145.0	5.23	96.7	0.0937	38.4	0.381	-70.4
1200	0.520	-156.8	4.45	90.7	0.0986	37.7	0.340	-74.6
1400	0.515	-166.9	3.86	86.0	0.103	38.7	0.309	-77.7
1600	0.518	-176.0	3.44	81.1	0.107	40.0	0.287	-81.2
1800	0.523	176.5	3.11	77.3	0.111	41.2	0.268	-85.1
2000	0.537	170.1	2.82	73.5	0.116	42.4	0.256	-89.0

S Parameter

 $(V_{CE} = 5 \text{ V}, I_C = 20 \text{ mA}, Z_O = 50 \Omega)$

Freq. (MHz)	S11		S21		S12		S22	
	MAG.	ANG.	MAG.	ANG.	MAG.	ANG.	MAG.	ANG.
200	0.542	-69.9	24.74	128.7	0.0296	55.5	0.631	-52.5
400	0.520	-136.2	15.31	109.4	0.0398	50.2	0.395	-72.9
600	0.516	-156.3	10.81	99.5	0.0470	52.8	0.285	-83.6
800	0.519	-169.1	8.29	93.5	0.0547	55.1	0.225	-91.3
1000	0.525	-179.2	6.70	88.5	0.0624	57.9	0.189	-97.5
1200	0.538	173.6	5.63	84.1	0.0712	60.2	0.166	-102.8
1400	0.540	167.5	4.85	80.9	0.0805	61.5	0.151	-107.9
1600	0.554	161.6	4.29	77.5	0.0895	62.8	0.140	-112.6
1800	0.567	159.5	3.86	74.3	0.0991	63.8	0.134	-118.1
2000	0.580	151.7	3.48	71.6	0.109	64.3	0.129	-122.5

S Parameter $(V_{CE} = 1 \text{ V}, I_C = 5 \text{ mA}, Z_O = 50 \Omega)$

Freq. (MHz)	S11		S21		S12		S22	
	MAG.	ANG.	MAG.	ANG.	MAG.	ANG.	MAG.	ANG.
200	0.739	-65.4	11.99	140.8	0.0681	56.9	0.793	-44.9
400	0.643	-106.5	8.54	118.9	0.0957	41.5	0.576	-72.1
600	0.603	-132.0	6.34	106.4	0.107	34.9	0.446	-89.4
800	0.586	-148.7	4.99	97.9	0.114	32.6	0.369	-101.9
1000	0.578	-162.1	4.08	90.9	0.118	32.6	0.323	-112.0
1200	0.580	-171.9	3.45	86.0	0.124	32.7	0.396	-120.1
1400	0.588	179.9	2.99	81.7	0.129	33.3	0.275	-127.0
1600	0.596	172.9	2.67	77.2	0.134	34.3	0.263	-133.0
1800	0.607	166.8	2.41	73.4	0.139	35.9	0.256	-139.5
2000	0.617	161.0	2.20	70.0	0.145	36.9	0.254	-144.7

S Parameter $(V_{CE} = 1 \text{ V}, I_C = 20 \text{ mA}, Z_O = 50 \Omega)$

Freq. (MHz)	S11		S21		S12		S22	
	MAG.	ANG.	MAG.	ANG.	MAG.	ANG.	MAG.	ANG.
200	0.588	-127.7	19.25	119.0	0.0389	47.2	0.527	-86.7
400	0.618	-157.6	11.00	102.5	0.0483	45.3	0.380	-120.8
600	0.627	-171.4	7.62	94.6	0.0570	49.0	0.334	-139.3
800	0.639	179.6	5.80	89.2	0.0662	52.6	0.315	-150.9
1000	0.650	172.1	4.66	84.5	0.0768	55.9	0.306	-158.9
1200	0.656	-166.4	3.94	81.1	0.873	57.7	0.302	-165.4
1400	0.664	160.7	3.40	78.2	0.0996	59.2	0.301	-170.5
1600	0.677	156.5	3.03	75.2	0.110	60.2	0.301	-174.6
1800	0.689	151.6	2.71	71.9	0.122	61.1	0.304	-178.4
2000	0.696	147.5	2.47	69.2	0.134	61.2	0.306	178.2

Package Dimensions

As of January, 2003
Unit: mm

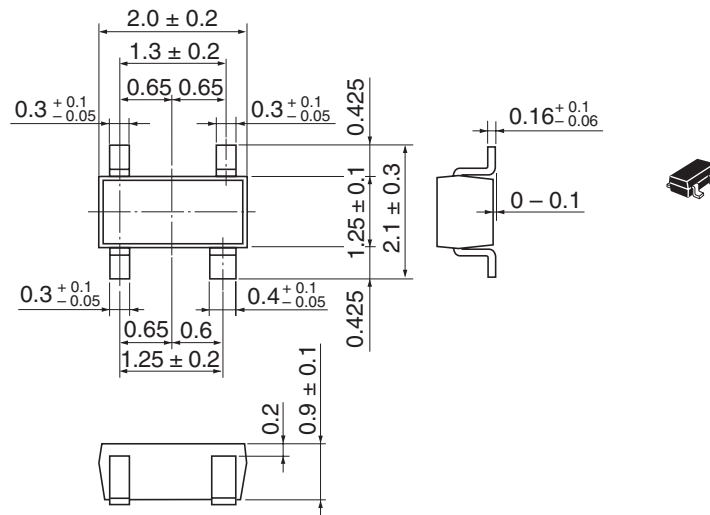

Package Code	CMPAK-4(T)
JEDEC	—
JEITA	Conforms
Mass (reference value)	0.006 g

Ordering Information

Part Name	Quantity	Shipping Container
2SC4995	3000 pcs	φ178 mm Taping Reel (TL)

Note: For some grades, production may be terminated. Please contact the Renesas sales office to check the state of production before ordering the product.

Renesas Technology Corp. Sales Strategic Planning Div. Nippon Bldg., 2-6-2, Ohte-machi, Chiyoda-ku, Tokyo 100-0004, Japan

Keep safety first in your circuit designs!

1. Renesas Technology Corp. puts the maximum effort into making semiconductor products better and more reliable, but there is always the possibility that trouble may occur with them. Trouble with semiconductors may lead to personal injury, fire or property damage. Remember to give due consideration to safety when making your circuit designs, with appropriate measures such as (i) placement of substitutive, auxiliary circuits, (ii) use of nonflammable material or (iii) prevention against any malfunction or mishap.

Notes regarding these materials

1. These materials are intended as a reference to assist our customers in the selection of the Renesas Technology Corp. product best suited to the customer's application; they do not convey any license under any intellectual property rights, or any other rights, belonging to Renesas Technology Corp. or a third party.
 2. Renesas Technology Corp. assumes no responsibility for any damage, or infringement of any third-party's rights, originating in the use of any product data, diagrams, charts, programs, algorithms, or circuit application examples contained in these materials.
 3. All information contained in these materials, including product data, diagrams, charts, programs and algorithms represents information on products at the time of publication of these materials, and are subject to change by Renesas Technology Corp. without notice due to product improvements or other reasons. It is therefore recommended that customers contact Renesas Technology Corp. or an authorized Renesas Technology Corp. product distributor for the latest product information before purchasing a product listed herein.
The information described here may contain technical inaccuracies or typographical errors.
Renesas Technology Corp. assumes no responsibility for any damage, liability, or other loss rising from these inaccuracies or errors.
Please also pay attention to information published by Renesas Technology Corp. by various means, including the Renesas Technology Corp. Semiconductor home page (<http://www.renesas.com>).
 4. When using any or all of the information contained in these materials, including product data, diagrams, charts, programs, and algorithms, please be sure to evaluate all information as a total system before making a final decision on the applicability of the information and products. Renesas Technology Corp. assumes no responsibility for any damage, liability or other loss resulting from the information contained herein.
 5. Renesas Technology Corp. semiconductors are not designed or manufactured for use in a device or system that is used under circumstances in which human life is potentially at stake. Please contact Renesas Technology Corp. or an authorized Renesas Technology Corp. product distributor when considering the use of a product contained herein for any specific purposes, such as apparatus or systems for transportation, vehicular, medical, aerospace, nuclear, or undersea repeater use.
 6. The prior written approval of Renesas Technology Corp. is necessary to reprint or reproduce in whole or in part these materials.
 7. If these products or technologies are subject to the Japanese export control restrictions, they must be exported under a license from the Japanese government and cannot be imported into a country other than the approved destination.
Any diversion or reexport contrary to the export control laws and regulations of Japan and/or the country of destination is prohibited.
 8. Please contact Renesas Technology Corp. for further details on these materials or the products contained therein.
-



RENESAS SALES OFFICES

<http://www.renesas.com>

Renesas Technology America, Inc.

450 Holger Way, San Jose, CA 95134-1368, U.S.A
Tel: <1> (408) 382-7500 Fax: <1> (408) 382-7501

Renesas Technology Europe Limited.

Dukes Meadow, Millboard Road, Bourne End, Buckinghamshire, SL8 5FH, United Kingdom
Tel: <44> (1628) 585 100, Fax: <44> (1628) 585 900

Renesas Technology Europe GmbH

Dornacher Str. 3, D-85622 Feldkirchen, Germany
Tel: <49> (89) 380 70 0, Fax: <49> (89) 929 30 11

Renesas Technology Hong Kong Ltd.

7/F., North Tower, World Finance Centre, Harbour City, Canton Road, Hong Kong
Tel: <852> 2265-6688, Fax: <852> 2375-6836

Renesas Technology Taiwan Co., Ltd.

FL 10, #99, Fu-Hsing N. Rd., Taipei, Taiwan
Tel: <886> (2) 2715-2888, Fax: <886> (2) 2713-2999

Renesas Technology (Shanghai) Co., Ltd.

26/F., Ruijin Building, No.205 Maoming Road (S), Shanghai 200020, China
Tel: <86> (21) 6472-1001, Fax: <86> (21) 6415-2952

Renesas Technology Singapore Pte. Ltd.

1, Harbour Front Avenue, #06-10, Keppel Bay Tower, Singapore 098632
Tel: <65> 6213-0200, Fax: <65> 6278-8001

