

To all our customers

---

## **Regarding the change of names mentioned in the document, such as Hitachi Electric and Hitachi XX, to Renesas Technology Corp.**

---

The semiconductor operations of Mitsubishi Electric and Hitachi were transferred to Renesas Technology Corporation on April 1st 2003. These operations include microcomputer, logic, analog and discrete devices, and memory chips other than DRAMs (flash memory, SRAMs etc.) Accordingly, although Hitachi, Hitachi, Ltd., Hitachi Semiconductors, and other Hitachi brand names are mentioned in the document, these names have in fact all been changed to Renesas Technology Corp. Thank you for your understanding. Except for our corporate trademark, logo and corporate statement, no changes whatsoever have been made to the contents of the document, and these changes do not constitute any alteration to the contents of the document itself.

Renesas Technology Home Page: <http://www.renesas.com>

Renesas Technology Corp.  
Customer Support Dept.  
April 1, 2003

## Cautions

Keep safety first in your circuit designs!

1. Renesas Technology Corporation puts the maximum effort into making semiconductor products better and more reliable, but there is always the possibility that trouble may occur with them. Trouble with semiconductors may lead to personal injury, fire or property damage.

Remember to give due consideration to safety when making your circuit designs, with appropriate measures such as (i) placement of substitutive, auxiliary circuits, (ii) use of nonflammable material or (iii) prevention against any malfunction or mishap.

Notes regarding these materials

1. These materials are intended as a reference to assist our customers in the selection of the Renesas Technology Corporation product best suited to the customer's application; they do not convey any license under any intellectual property rights, or any other rights, belonging to Renesas Technology Corporation or a third party.
2. Renesas Technology Corporation assumes no responsibility for any damage, or infringement of any third-party's rights, originating in the use of any product data, diagrams, charts, programs, algorithms, or circuit application examples contained in these materials.
3. All information contained in these materials, including product data, diagrams, charts, programs and algorithms represents information on products at the time of publication of these materials, and are subject to change by Renesas Technology Corporation without notice due to product improvements or other reasons. It is therefore recommended that customers contact Renesas Technology Corporation or an authorized Renesas Technology Corporation product distributor for the latest product information before purchasing a product listed herein.  
The information described here may contain technical inaccuracies or typographical errors. Renesas Technology Corporation assumes no responsibility for any damage, liability, or other loss rising from these inaccuracies or errors.  
Please also pay attention to information published by Renesas Technology Corporation by various means, including the Renesas Technology Corporation Semiconductor home page (<http://www.renesas.com>).
4. When using any or all of the information contained in these materials, including product data, diagrams, charts, programs, and algorithms, please be sure to evaluate all information as a total system before making a final decision on the applicability of the information and products. Renesas Technology Corporation assumes no responsibility for any damage, liability or other loss resulting from the information contained herein.
5. Renesas Technology Corporation semiconductors are not designed or manufactured for use in a device or system that is used under circumstances in which human life is potentially at stake. Please contact Renesas Technology Corporation or an authorized Renesas Technology Corporation product distributor when considering the use of a product contained herein for any specific purposes, such as apparatus or systems for transportation, vehicular, medical, aerospace, nuclear, or undersea repeater use.
6. The prior written approval of Renesas Technology Corporation is necessary to reprint or reproduce in whole or in part these materials.
7. If these products or technologies are subject to the Japanese export control restrictions, they must be exported under a license from the Japanese government and cannot be imported into a country other than the approved destination.  
Any diversion or reexport contrary to the export control laws and regulations of Japan and/or the country of destination is prohibited.
8. Please contact Renesas Technology Corporation for further details on these materials or the products contained therein.

---

# HD74SSTV16857

## 1:1 14-bit SSTL\_2 Registered Buffer



ADE-205-336F (Z)

Rev.6  
June. 2001

---

### Description

The HD74SSTV16857 is a 14-bit registered buffer designed for 2.3 V to 2.7 V V<sub>cc</sub> operation and LVCMOS reset ( $\overline{\text{RESET}}$ ) input / SSTL\_2 data (D) inputs and CLK input.

Data flow from D to Q is controlled by differential clock pins (CLK,  $\overline{\text{CLK}}$ ) and the  $\overline{\text{RESET}}$ . Data is triggered on the positive edge of the positive clock (CLK), and the negative clock ( $\overline{\text{CLK}}$ ) must be used to maintain noise margins. When  $\overline{\text{RESET}}$  is low, all registers are reset and all outputs are low.

To ensure defined outputs from the register before a stable clock has been supplied,  $\overline{\text{RESET}}$  must be held in the low state during power up.

### Features

- Supports LVCMOS reset ( $\overline{\text{RESET}}$ ) input / SSTL\_2 data (D) inputs and CLK input
- Differential SSTL\_2 (Stub series terminated logic) CLK signal
- Flow through architecture optimizes PCB layout
- Package type

| Package type | Package code | Package suffix | Taping code           |
|--------------|--------------|----------------|-----------------------|
| TSSOP-48 pin | TTP-48DB     | T              | EL (1,000 pcs / Reel) |
| TVSOP-48 pin | TTP-48DEV    | N              | EL (1,000 pcs / Reel) |

---

**Function Table**

| Inputs                    |                         |        |   | Output Q   |
|---------------------------|-------------------------|--------|---|------------|
| $\overline{\text{RESET}}$ | $\overline{\text{CLK}}$ | CLK    | D |            |
| L                         | X                       | X      | X | L          |
| H                         | ↓                       | ↑      | H | H          |
| H                         | ↓                       | ↑      | L | L          |
| H                         | L or H                  | H or L | X | $Q_0^{*1}$ |

H : High level

L : Low level

X : Immaterial

↑ : Low to high transition

↓ : High to low transition

Note: 1. Output level before the indicated steady state input conditions were established.

Pin Arrangement

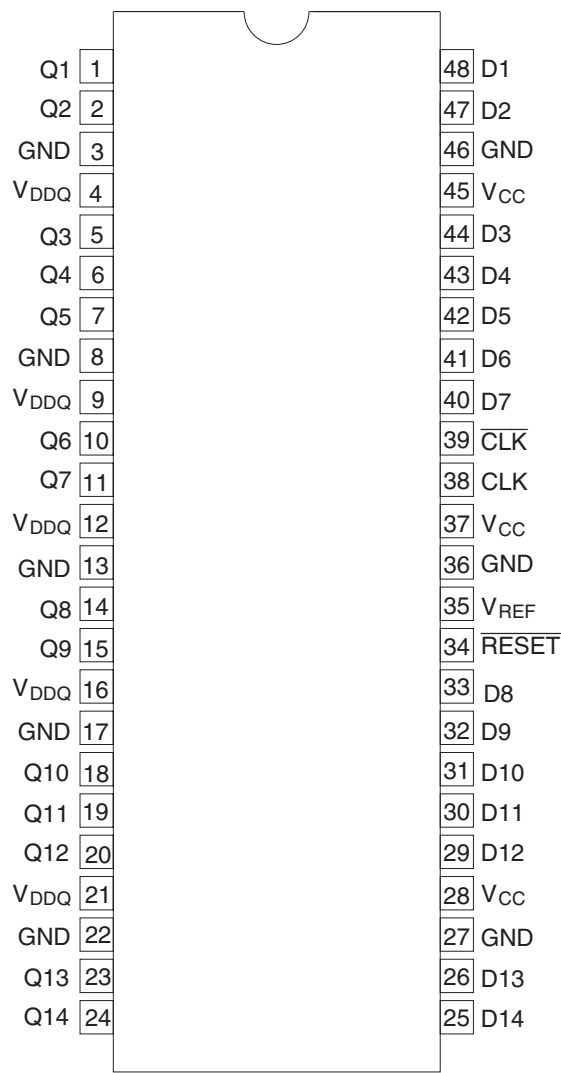

(Top view)

## Absolute Maximum Ratings

| Item  | Symbol                            | Ratings               | Unit                        | Conditions                   |
|---|-----------------------------------|-----------------------|-----------------------------|------------------------------|
| Supply voltage  | $V_{CC}$ or $V_{DDQ}$             | -0.5 to 3.6           | V                           |                              |
| Input voltage <sup>1</sup>  | $V_I$                             | -0.5 to $V_{DDQ}+0.5$ | V                           |                              |
| Output voltage <sup>1,2</sup>   | $V_O$                             | -0.5 to $V_{DDQ}+0.5$ | V                           |                              |
| Input clamp current   | $I_{IK}$                          | ±50                   | mA                          | $V_I < 0$ or $V_I > V_{CC}$  |
| Output clamp current  | $I_{OK}$                          | ±50                   | mA                          | $V_O < 0$ or $V_O > V_{DDQ}$ |
| Continuous output current   | $I_O$                             | ±50                   | mA                          | $V_O = 0$ to $V_{DDQ}$       |
| $V_{CC}$ , $V_{DDQ}$ or GND current / pin                               | $I_{CC}$ , $I_{DDQ}$ or $I_{GND}$ | ±100                  | mA                          |                              |
| Maximum power dissipation<br>at $T_a = 55^\circ\text{C}$ (in still air) | $P_T$                             | 115                   | $^\circ\text{C} / \text{W}$ | TSSOP                        |
| Storage temperature   | Tstg                              | -65 to +150           | $^\circ\text{C}$            |                              |

Notes: Stresses beyond those listed under “absolute maximum ratings” may cause permanent damage to the device. These are stress ratings only, and functional operation of the device at these or any other conditions beyond those indicated under “recommended operating conditions” is not implied. Exposure to absolute maximum rated conditions for extended periods may affect device reliability.

1. The input and output negative voltage ratings may be exceeded if the input and output clamp current ratings are observed.
2. This current will flow only when the output is in the high state and  $V_O > V_{DDQ}$ .

## Recommended Operating Conditions

| Item                                       | Symbol    | Min                | Typ       | Max                | Unit | Conditions                     |
|--|-----------|--------------------|-----------|--------------------|------|--------------------------------|
| Supply voltage                             | $V_{CC}$  | $V_{DDQ}$          | 2.5       | 2.7                | V    |                                |
| Output supply voltage                      | $V_{DDQ}$ | 2.3                | 2.5       | 2.7                | V    |                                |
| Reference voltage                          | $V_{REF}$ | 1.15               | 1.25      | 1.35               | V    | $V_{REF} = 0.5 \times V_{DDQ}$ |
| Termination voltage                        | $V_{TT}$  | $V_{REF} - 40$ mV  | $V_{REF}$ | $V_{REF} + 40$ mV  | V    |                                |
| Input voltage                              | $V_I$     | 0                  | —         | $V_{CC}$           | V    |                                |
| AC high level input voltage                | $V_{IH}$  | $V_{REF} + 310$ mV | —         | —                  | V    | D                              |
| AC low level input voltage                 | $V_{IL}$  | —                  | —         | $V_{REF} - 310$ mV | V    | D                              |
| DC high level input voltage                | $V_{IH}$  | $V_{REF} + 150$ mV | —         | —                  | V    | D                              |
| DC low level input voltage                 | $V_{IL}$  | —                  | —         | $V_{REF} - 150$ mV | V    | D                              |
| High level input voltage                   | $V_{IH}$  | 1.7                | —         | $V_{DDQ} + 0.3$    | V    | $\overline{\text{RESET}}$      |
| Low level input voltage                    | $V_{IL}$  | -0.3               | —         | 0.7                | V    | $\overline{\text{RESET}}$      |
| Differential (Common mode range)           | $V_{CMR}$ | 0.97               | —         | 1.53               | V    | CLK, $\overline{\text{CLK}}$   |
| input voltage (Minimum peak to peak input) | $V_{PP}$  | 360                | —         | —                  | mV   | CLK, $\overline{\text{CLK}}$   |
| High level output current                  | $I_{OH}$  | —                  | —         | -20                | mA   |                                |
| Low level output current                   | $I_{OL}$  | —                  | —         | 20                 | mA   |                                |
| Operating temperature                      | $T_a$     | 0                  | —         | 70                 | °C   |                                |

Note: The  $\overline{\text{RESET}}$  input of the device must be held at  $V_{DDQ}$  or GND to ensure proper device operation. The differential inputs must not be floating, unless  $\overline{\text{RESET}}$  is low.

## Logic Diagram

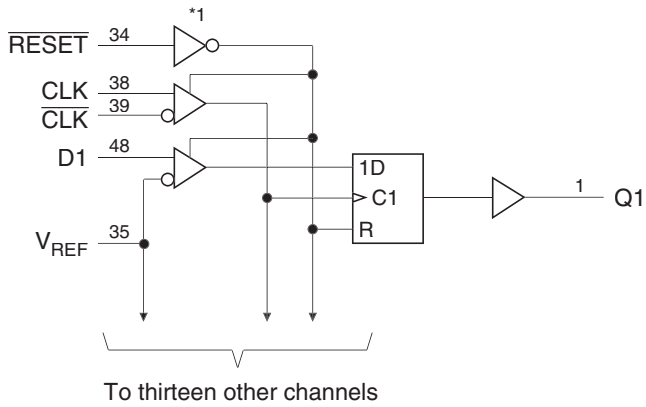

Note: 1.  $\overline{\text{RESET}}$  input gate is connected to  $V_{\text{DDQ}}$ .

## Electrical Characteristics

| Item  | Symbol                          | V <sub>CC</sub> (V) | Min                  | Typ | Max              | Unit  | Test Conditions   |  |
|---|---------------------------------|---------------------|----------------------|-----|------------------|---|---|--|
| Input diode voltage   | V <sub>IK</sub>                 | 2.3                 | —                    | —   | -1.2             | V   | I <sub>IN</sub> = -18 mA  |  |
| Output voltage  | V <sub>OH</sub>                 | 2.3 to 2.7          | V <sub>CC</sub> -0.2 | —   | —                | V   | I <sub>OH</sub> = -100 μA   |  |
|   |                                 | 2.3                 | 1.95                 | —   | V <sub>DDQ</sub> |   | I <sub>OH</sub> = -16 mA  |  |
|   | V <sub>OL</sub>                 | 2.3 to 2.7          | —                    | —   | 0.2              |   | I <sub>OL</sub> = 100 μA  |  |
|   |                                 | 2.3                 | 0                    | —   | 0.35             |   | I <sub>OL</sub> = 16 mA   |  |
| Input current (All inputs)  | I <sub>IN</sub>                 | 2.7                 | —                    | —   | ±5               | μA  | V <sub>IN</sub> = 2.7 V or 0  |  |
| Quiescent supply current  | I <sub>CC</sub> <sup>*2</sup>   | 2.7                 | —                    | —   | 45               | mA  | V <sub>IN</sub> = V <sub>IH(AC)</sub> or V <sub>IL(AC)</sub> , I <sub>O</sub> = 0   |  |
| Standby current   | I <sub>CC (stdy)</sub>          | 2.7                 | —                    | —   | 10               | μA  | $\overline{\text{RESET}}$ = GND   |  |
| Dynamic operating clock only  | I <sub>CCD</sub> <sup>*2</sup>  | 2.7                 | —                    | —   | 90               | μA/<br>MHz  | $\overline{\text{RESET}}$ = V <sub>CC</sub> ,<br>clock V <sub>I</sub> = V <sub>IH(AC)</sub> or V <sub>IL(AC)</sub> ,<br>CLK and $\overline{\text{CLK}}$ switching 50%<br>duty cycle   |  |
| Dynamic operating per each data input                               | I <sub>CCD</sub> <sup>*2</sup>  | 2.7                 | —                    | —   | 15               | μA/<br>MHz  | $\overline{\text{RESET}}$ = V <sub>CC</sub> ,<br>clock V <sub>I</sub> = V <sub>IH(AC)</sub> or V <sub>IL(AC)</sub> ,<br>CLK and $\overline{\text{CLK}}$ switching 50%<br>/ duty cycle. One data input<br>data switching at half clock<br>input frequency, 50% duty cycle. |  |
| Output high <sup>*3</sup>   | r <sub>OH</sub>                 | 2.3 to 2.7          | 7                    | —   | 22 <sup>*4</sup> | Ω   | I <sub>OH</sub> = -20 mA  |  |
| Output low <sup>*3</sup>  | r <sub>OL</sub>                 | 2.3 to 2.7          | 7                    | —   | 22 <sup>*4</sup> | Ω   | I <sub>OL</sub> = 20 mA   |  |
| r <sub>OH</sub> - r <sub>OL</sub>   each separate bit <sup>*3</sup> | r <sub>O(Δ)</sub>               | 2.5                 | —                    | —   | 4                | Ω   | I <sub>O</sub> = 20 mA, Ta = 25°C   |  |
| Input capacitance   | Data inputs                     | C <sub>IN</sub>     | 2.5 <sup>*1</sup>    | 2.5 | —                | 3.5   | pF  | V <sub>I</sub> = V <sub>REF</sub> ± 310 mV |
|   | CLK and $\overline{\text{CLK}}$ |                     | 2.5                  | —   | 3.5              | V <sub>CMR</sub> = 1.25 V, V <sub>PP</sub> = 360 mV |   |  |
|   | $\overline{\text{RESET}}$       |                     | —                    | 3.0 | —                | V <sub>I</sub> = V <sub>CC</sub> or GND             |   |  |

Notes: 1. All typical values are at V<sub>CC</sub> = 2.5 V, Ta = 25°C.

2. Total I<sub>CC</sub> (max) = I<sub>CC</sub> + {I<sub>CCD</sub> (clock) × f(clock)} + {I<sub>CCD</sub> (Data) × 1/2f(clock) × 14}

3. This is effective in the case that it did terminate by resistance.

4. See figure. 1, 2

## Switching Characteristics

| Item                              | Symbol                          | $V_{CC} = 2.5 \pm 0.2 \text{ V}$ |      | Unit    | Test Condition   |   |
|-----------------------------------|---------------------------------|----------------------------------|------|---------|--|---|
|                                   |                                 | Min                              | Max  |         |  |   |
| Clock frequency <sup>*1</sup>     | $f_{\text{clock}}$              | —                                | 200  | MHz     |  |   |
| Setup time                        | Fast slew rate <sup>*4, 6</sup> | $t_{\text{su}}$                  | 0.75 | —       | ns   | Data before $\text{CLK}\uparrow, \overline{\text{CLK}}\downarrow$ |
|                                   | Slow slew rate <sup>*5, 6</sup> |                                  | 0.9  | —       |  |   |
| Hold time                         | Fast slew rate <sup>*4, 6</sup> | $t_{\text{h}}$                   | 0.75 | —       | ns   | Data after $\text{CLK}\uparrow, \overline{\text{CLK}}\downarrow$  |
|                                   | Slow slew rate <sup>*5, 6</sup> |                                  | 0.9  | —       |  |   |
| Differential inputs active time   | $t_{\text{act}}$                | 22                               | —    | ns      | Data inputs must be low after $\overline{\text{RESET}}$ high.  |   |
| Differential inputs inactive time | $t_{\text{inact}}$              | 22                               | —    | ns      | Data and clock inputs must be held at valid levels (not floating) after $\overline{\text{RESET}}$ low. |   |
| Pulse width                       | $t_{\text{w}}$                  | 2.5                              | —    | ns      | $\text{CLK}, \overline{\text{CLK}}$ "H" or "L"   |   |
| Output slew <sup>*3</sup>         | $t_{\text{SL}}$                 | 1                                | 4    | volt/ns |  |   |

$$(C_L = 30 \text{ pF}, R_L = 50 \Omega, V_{\text{REF}} = V_{\text{TT}} = V_{\text{DDQ}} \times 0.5)$$

| Item                                 | Symbol                           | $V_{CC} = 2.5 \pm 0.2 \text{ V}$ |     |     | Unit | FROM (Input)                        | TO (Output)               |
|--------------------------------------|----------------------------------|----------------------------------|-----|-----|------|-------------------------------------|---------------------------|
|                                      |                                  | Min                              | Typ | Max |      |                                     |                           |
| Maximum clock frequency              | $f_{\text{max}}$                 | 200                              | —   | —   | MHz  |                                     |                           |
| Propagation delay time <sup>*2</sup> | $t_{\text{PLH}}, t_{\text{PHL}}$ | 1.1                              | —   | 2.8 | ns   | $\text{CLK}, \overline{\text{CLK}}$ | Q                         |
|                                      | $t_{\text{PHL}}$                 | —                                | —   | 5.0 |      |                                     | $\overline{\text{RESET}}$ |

- Notes:
1. Although the clock is differential, all timing is relative to  $\text{CLK}$  going high and  $\overline{\text{CLK}}$  going low.
  2. This timing relationship is specified into test load (see waveforms – 3, 4) with all of the outputs switching.
  3. Assumes into an equivalent, distributed load to the address net structure defined in the application information provided in this specification.
  4. For data signal input slew rate  $\geq 1 \text{ V/ns}$ .
  5. For data signal input slew rate  $\geq 0.5 \text{ V/ns}$  and  $< 1 \text{ V/ns}$ .
  6.  $\text{CLK}, \overline{\text{CLK}}$  signals input slew rates are  $\geq 1 \text{ V/ns}$ .

Test Circuit

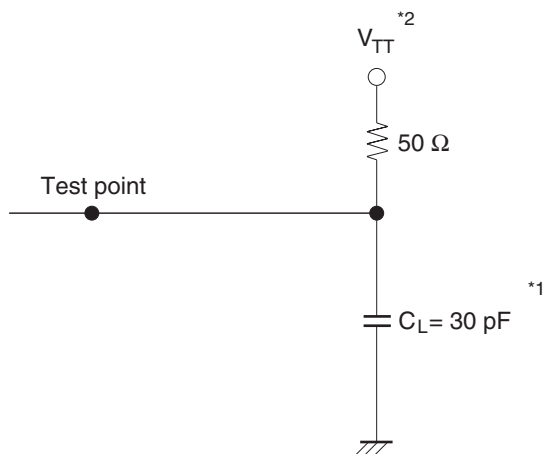

- Notes:
1.  $C_L$  includes probe and jig capacitance.
  2.  $V_{TT} = V_{REF} = V_{DDQ} \times 0.5$

Waveforms - 1

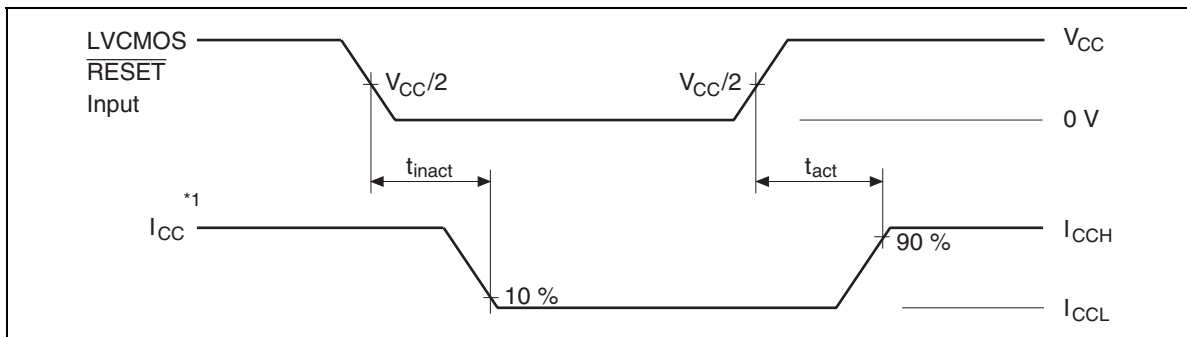

## Waveforms – 2

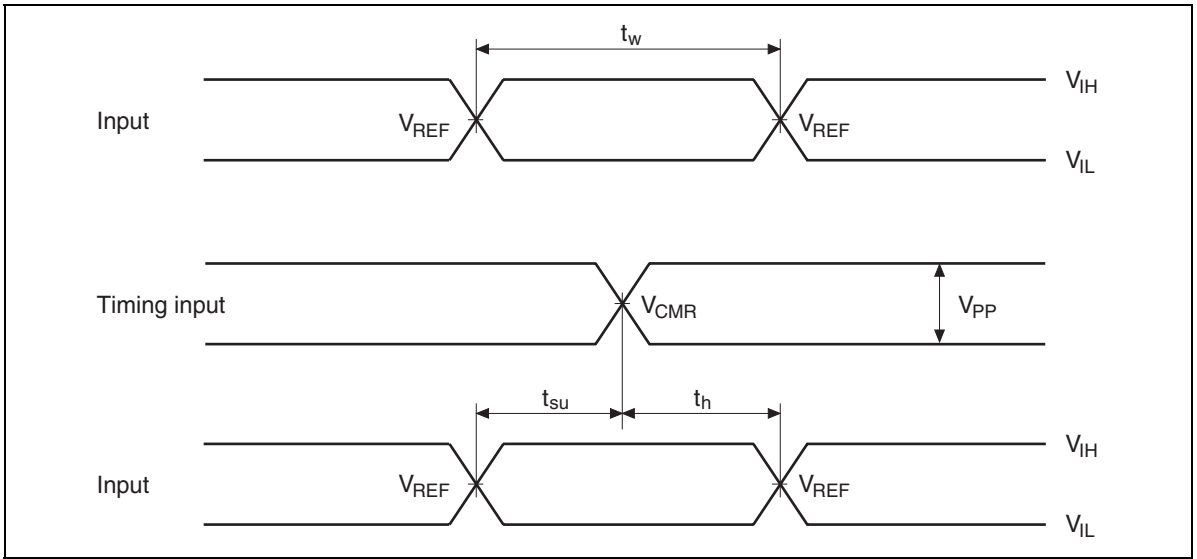

## Waveforms – 3

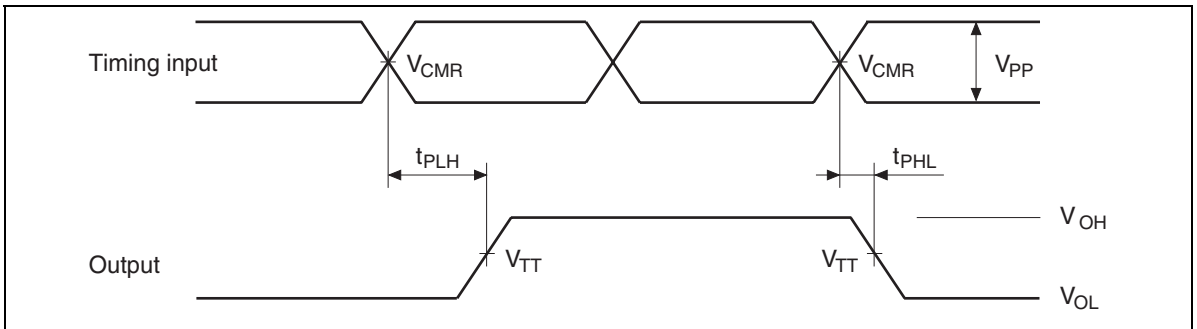

Waveforms – 4

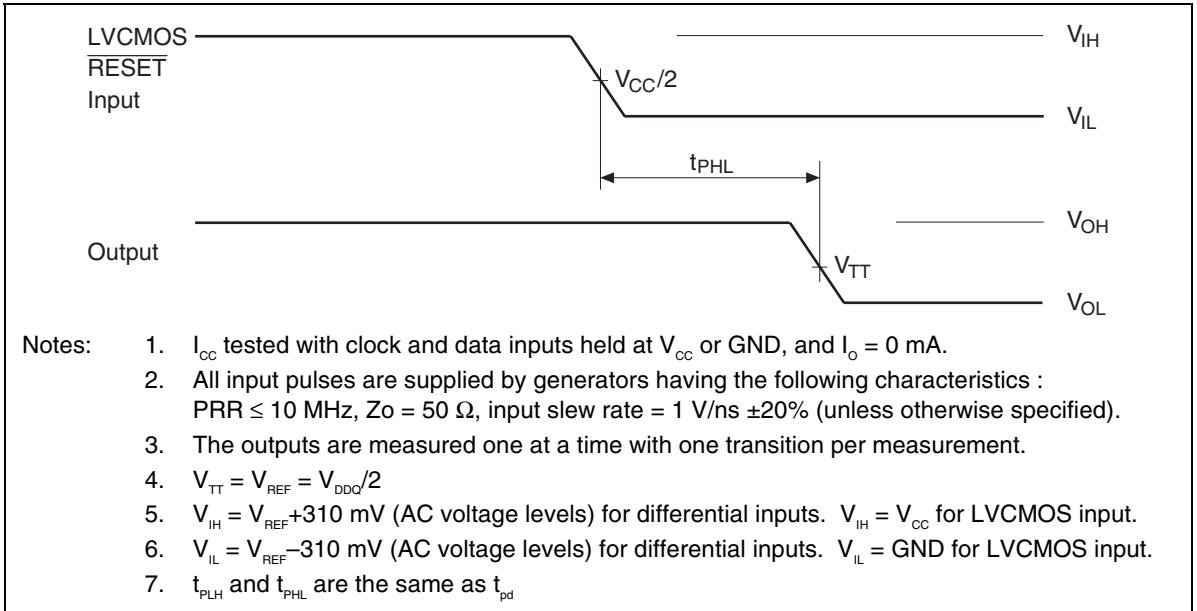

## Application Data

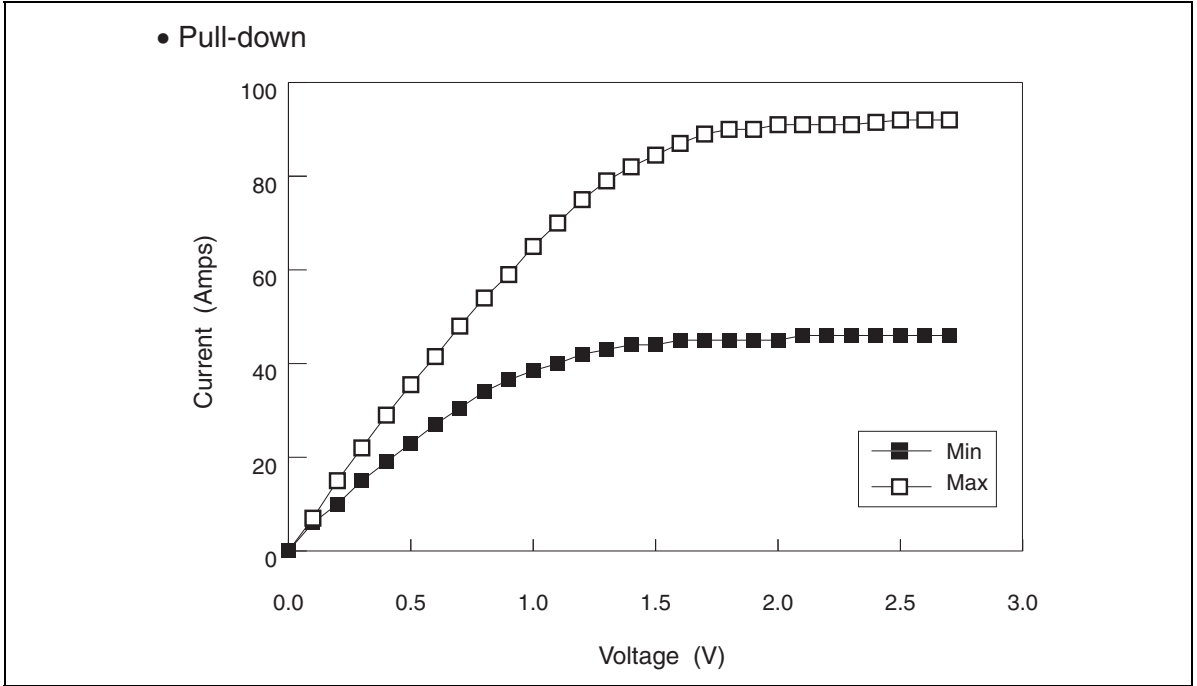

Figure . 1

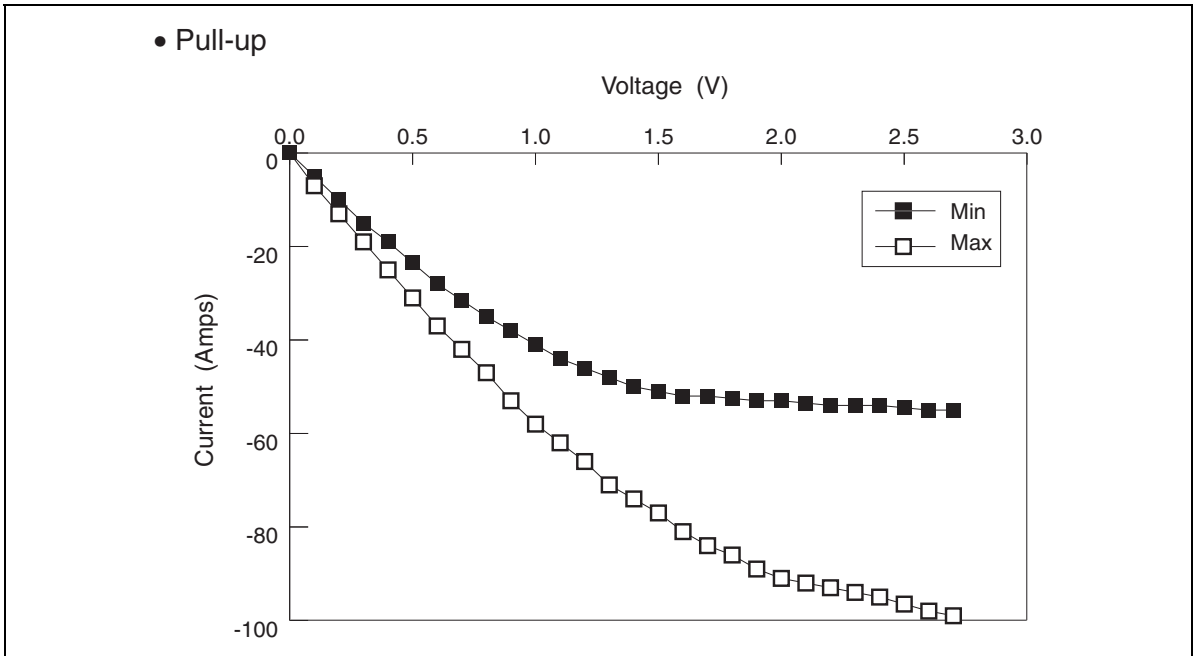

Figure . 2

## Curve Data

| Voltage (V) | Pull-down |        | Pull-up |        |
|-------------|-----------|--------|---------|--------|
|             | I (mA)    | I (mA) | I (mA)  | I (mA) |
|             | Min       | Max    | Min     | Max    |
| 0.0         | 0         | 0      | 0       | 0      |
| 0.1         | 6         | 7      | -5      | -7     |
| 0.2         | 10        | 15     | -10     | -13    |
| 0.3         | 15        | 22     | -15     | -19    |
| 0.4         | 19        | 29     | -19     | -25    |
| 0.5         | 23        | 35.5   | -23.5   | -31    |
| 0.6         | 27        | 41.5   | -28     | -37    |
| 0.7         | 30.5      | 48     | -31.5   | -42    |
| 0.8         | 34        | 54     | -35     | -47    |
| 0.9         | 36.5      | 59     | -38     | -53    |
| 1.0         | 38.5      | 65     | -41     | -58    |
| 1.1         | 40        | 70     | -44     | -62    |
| 1.2         | 42        | 75     | -46     | -66    |
| 1.3         | 43        | 79     | -48     | -71    |
| 1.4         | 44        | 82     | -50     | -74    |
| 1.5         | 44        | 84.5   | -51     | -77    |
| 1.6         | 45        | 87     | -52     | -81    |
| 1.7         | 45        | 89     | -52     | -84    |
| 1.8         | 45        | 90     | -52.5   | -86    |
| 1.9         | 45        | 90     | -53     | -89    |
| 2.0         | 45        | 91     | -53     | -91    |
| 2.1         | 46        | 91     | -53.5   | -92    |
| 2.2         | 46        | 91     | -54     | -93    |
| 2.3         | 46        | 91     | -54     | -94    |
| 2.4         | 46        | 91.5   | -54     | -95    |
| 2.5         | 46        | 92     | -54.5   | -96.5  |
| 2.6         | 46        | 92     | -55     | -98    |
| 2.7         | 46        | 92     | -55     | -99    |

## Package Dimensions

Unit: mm

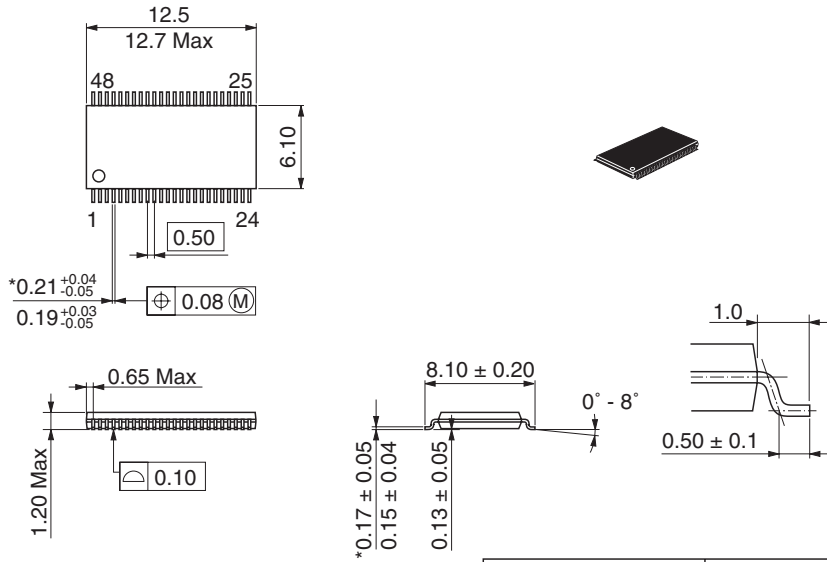

\*Dimension including the plating thickness  
Base material dimension

|                        |          |
|------------------------|----------|
| Hitachi Code           | TTP-48DB |
| JEDEC                  | —        |
| EIAJ                   | —        |
| Mass (reference value) | 0.20 g   |

Unit: mm

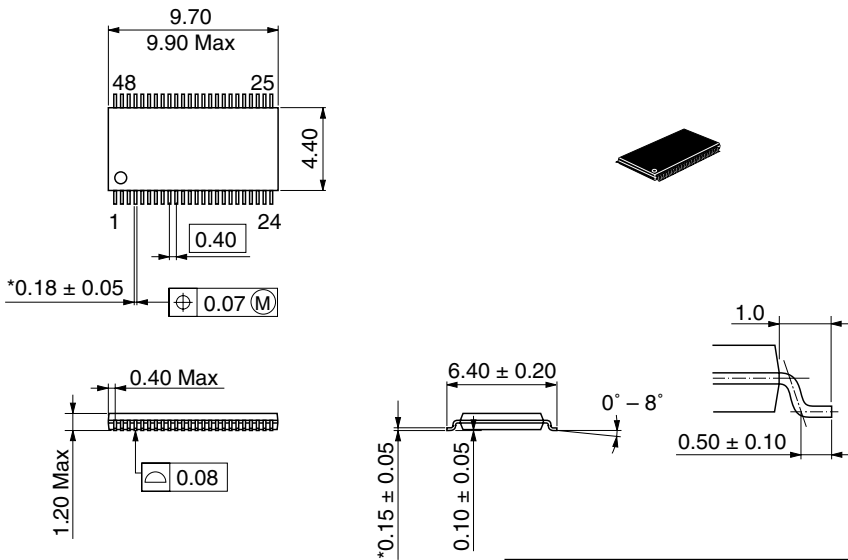

\*Pd plating

|                        |           |
|------------------------|-----------|
| Hitachi Code           | TTP-48DEV |
| JEDEC                  | —         |
| JEITA                  | —         |
| Mass (reference value) | —         |

## Disclaimer

1. Hitachi neither warrants nor grants licenses of any rights of Hitachi's or any third party's patent, copyright, trademark, or other intellectual property rights for information contained in this document. Hitachi bears no responsibility for problems that may arise with third party's rights, including intellectual property rights, in connection with use of the information contained in this document.
2. Products and product specifications may be subject to change without notice. Confirm that you have received the latest product standards or specifications before final design, purchase or use.
3. Hitachi makes every attempt to ensure that its products are of high quality and reliability. However, contact Hitachi's sales office before using the product in an application that demands especially high quality and reliability or where its failure or malfunction may directly threaten human life or cause risk of bodily injury, such as aerospace, aeronautics, nuclear power, combustion control, transportation, traffic, safety equipment or medical equipment for life support.
4. Design your application so that the product is used within the ranges guaranteed by Hitachi particularly for maximum rating, operating supply voltage range, heat radiation characteristics, installation conditions and other characteristics. Hitachi bears no responsibility for failure or damage when used beyond the guaranteed ranges. Even within the guaranteed ranges, consider normally foreseeable failure rates or failure modes in semiconductor devices and employ systemic measures such as fail-safes, so that the equipment incorporating Hitachi product does not cause bodily injury, fire or other consequential damage due to operation of the Hitachi product.
5. This product is not designed to be radiation resistant.
6. No one is permitted to reproduce or duplicate, in any form, the whole or part of this document without written approval from Hitachi.
7. Contact Hitachi's sales office for any questions regarding this document or Hitachi semiconductor products.

## Sales Offices

# HITACHI

### Hitachi, Ltd.

Semiconductor & Integrated Circuits  
Nippon Bldg., 2-6-2, Ohte-machi, Chiyoda-ku, Tokyo 100-0004, Japan  
Tel: (03) 3270-2111 Fax: (03) 3270-5109

|     |              |   |
|-----|--------------|---|
| URL | NorthAmerica | : <a href="http://semiconductor.hitachi.com/">http://semiconductor.hitachi.com/</a>           |
|     | Europe       | : <a href="http://www.hitachi-eu.com/hel/ecg">http://www.hitachi-eu.com/hel/ecg</a>           |
|     | Asia         | : <a href="http://sicapac.hitachi-asia.com">http://sicapac.hitachi-asia.com</a>               |
|     | Japan        | : <a href="http://www.hitachi.co.jp/Sicd/indx.htm">http://www.hitachi.co.jp/Sicd/indx.htm</a> |

### For further information write to:

|  |  |   |  |
|--|--|---|--|
| Hitachi Semiconductor (America) Inc.<br>179 East Tasman Drive<br>San Jose, CA 95134<br>Tel: <1> (408) 433-1990<br>Fax: <1>(408) 433-0223 | Hitachi Europe Ltd.<br>Electronic Components Group<br>Whitebrook Park<br>Lower Cookham Road<br>Maidenhead<br>Berkshire SL6 8YA, United Kingdom<br>Tel: <44> (1628) 585000<br>Fax: <44> (1628) 585200 | Hitachi Asia Ltd.<br>Hitachi Tower<br>16 Collyer Quay #20-00<br>Singapore 049318<br>Tel: <65>-538-6533/538-8577<br>Fax: <65>-538-6933/538-3877<br>URL: <a href="http://www.hitachi.com.sg">http://www.hitachi.com.sg</a>  | Hitachi Asia (Hong Kong) Ltd.<br>Group III (Electronic Components)<br>7/F., North Tower<br>World Finance Centre,<br>Harbour City, Canton Road<br>Tsim Sha Tsui, Kowloon<br>Hong Kong<br>Tel: <852>-(2)-735-9218<br>Fax: <852>-(2)-730-0281<br>URL: <a href="http://semiconductor.hitachi.com.hk">http://semiconductor.hitachi.com.hk</a> |
|  | Hitachi Europe GmbH<br>Electronic Components Group<br>Dornacher Straße 3<br>D-85622 Feldkirchen, Munich<br>Germany<br>Tel: <49> (89) 9 9180-0<br>Fax: <49> (89) 9 29 30 00                           | Hitachi Asia Ltd.<br>(Taipei Branch Office)<br>4/F, No. 167, Tun Hwa North Road<br>Hung-Kuo Building<br>Taipei (105), Taiwan<br>Tel: <886>-(2)-2718-3666<br>Fax: <886>-(2)-2718-8180<br>Telex: 23222 HAS-TP<br>URL: <a href="http://www.hitachi.com.tw">http://www.hitachi.com.tw</a> |  |

Copyright © Hitachi, Ltd., 2001. All rights reserved. Printed in Japan.  
Colophon 4.0