

To all our customers

Regarding the change of names mentioned in the document, such as Hitachi Electric and Hitachi XX, to Renesas Technology Corp.

The semiconductor operations of Mitsubishi Electric and Hitachi were transferred to Renesas Technology Corporation on April 1st 2003. These operations include microcomputer, logic, analog and discrete devices, and memory chips other than DRAMs (flash memory, SRAMs etc.) Accordingly, although Hitachi, Hitachi, Ltd., Hitachi Semiconductors, and other Hitachi brand names are mentioned in the document, these names have in fact all been changed to Renesas Technology Corp. Thank you for your understanding. Except for our corporate trademark, logo and corporate statement, no changes whatsoever have been made to the contents of the document, and these changes do not constitute any alteration to the contents of the document itself.

Renesas Technology Home Page: <http://www.renesas.com>

Renesas Technology Corp.
Customer Support Dept.
April 1, 2003

Cautions

Keep safety first in your circuit designs!

1. Renesas Technology Corporation puts the maximum effort into making semiconductor products better and more reliable, but there is always the possibility that trouble may occur with them. Trouble with semiconductors may lead to personal injury, fire or property damage.

Remember to give due consideration to safety when making your circuit designs, with appropriate measures such as (i) placement of substitutive, auxiliary circuits, (ii) use of nonflammable material or (iii) prevention against any malfunction or mishap.

Notes regarding these materials

1. These materials are intended as a reference to assist our customers in the selection of the Renesas Technology Corporation product best suited to the customer's application; they do not convey any license under any intellectual property rights, or any other rights, belonging to Renesas Technology Corporation or a third party.
2. Renesas Technology Corporation assumes no responsibility for any damage, or infringement of any third-party's rights, originating in the use of any product data, diagrams, charts, programs, algorithms, or circuit application examples contained in these materials.
3. All information contained in these materials, including product data, diagrams, charts, programs and algorithms represents information on products at the time of publication of these materials, and are subject to change by Renesas Technology Corporation without notice due to product improvements or other reasons. It is therefore recommended that customers contact Renesas Technology Corporation or an authorized Renesas Technology Corporation product distributor for the latest product information before purchasing a product listed herein.
The information described here may contain technical inaccuracies or typographical errors. Renesas Technology Corporation assumes no responsibility for any damage, liability, or other loss rising from these inaccuracies or errors.
Please also pay attention to information published by Renesas Technology Corporation by various means, including the Renesas Technology Corporation Semiconductor home page (<http://www.renesas.com>).
4. When using any or all of the information contained in these materials, including product data, diagrams, charts, programs, and algorithms, please be sure to evaluate all information as a total system before making a final decision on the applicability of the information and products. Renesas Technology Corporation assumes no responsibility for any damage, liability or other loss resulting from the information contained herein.
5. Renesas Technology Corporation semiconductors are not designed or manufactured for use in a device or system that is used under circumstances in which human life is potentially at stake. Please contact Renesas Technology Corporation or an authorized Renesas Technology Corporation product distributor when considering the use of a product contained herein for any specific purposes, such as apparatus or systems for transportation, vehicular, medical, aerospace, nuclear, or undersea repeater use.
6. The prior written approval of Renesas Technology Corporation is necessary to reprint or reproduce in whole or in part these materials.
7. If these products or technologies are subject to the Japanese export control restrictions, they must be exported under a license from the Japanese government and cannot be imported into a country other than the approved destination.
Any diversion or reexport contrary to the export control laws and regulations of Japan and/or the country of destination is prohibited.
8. Please contact Renesas Technology Corporation for further details on these materials or the products contained therein.

HM62W4100HC Series

4M High Speed SRAM (1-Mword × 4-bit)



ADE-203-1202C (Z)

Rev. 2.0
Nov. 9, 2001

Description

The HM62W4100HC is a 4-Mbit high speed static RAM organized 1-Mword × 4-bit. It has realized high speed access time by employing CMOS process (6-transistor memory cell) and high speed circuit designing technology. It is most appropriate for the application which requires high speed and high density memory, such as cache and buffer memory in system. The HM62W4100HC is packaged in 400-mil 32-pin SOJ for high density surface mounting.

Features

- Single supply : 3.3 V ± 0.3 V
- Access time : 10/12 ns (max)
- Completely static memory
 - No clock or timing strobe required
- Equal access and cycle times
- Directly TTL compatible
 - All inputs and outputs
- Operating current : 115/100 mA (max)
- TTL standby current : 40 mA (max)
- CMOS standby current: 5 mA (max)
 - : 1 mA (max) (L-version)
- Data retention current : 0.6 mA (max) (L-version)
- Data retention voltage: 2 V (min) (L-version)
- Center V_{cc} and V_{ss} type pin out

HM62W4100HC Series

Ordering Information

Type No.	Access time	Device marking	Package
HM62W4100HCJP-10	10 ns	HM62W4100CJP10	400-mil 32-pin plastic SOJ (CP-32DB)
HM62W4100HCJP-12	12 ns	HM62W4100CJP12	
HM62W4100HCLJP-10	10 ns	HM62W4100CLJP10	
HM62W4100HCLJP-12	12 ns	HM62W4100CLJP12	

Pin Arrangement

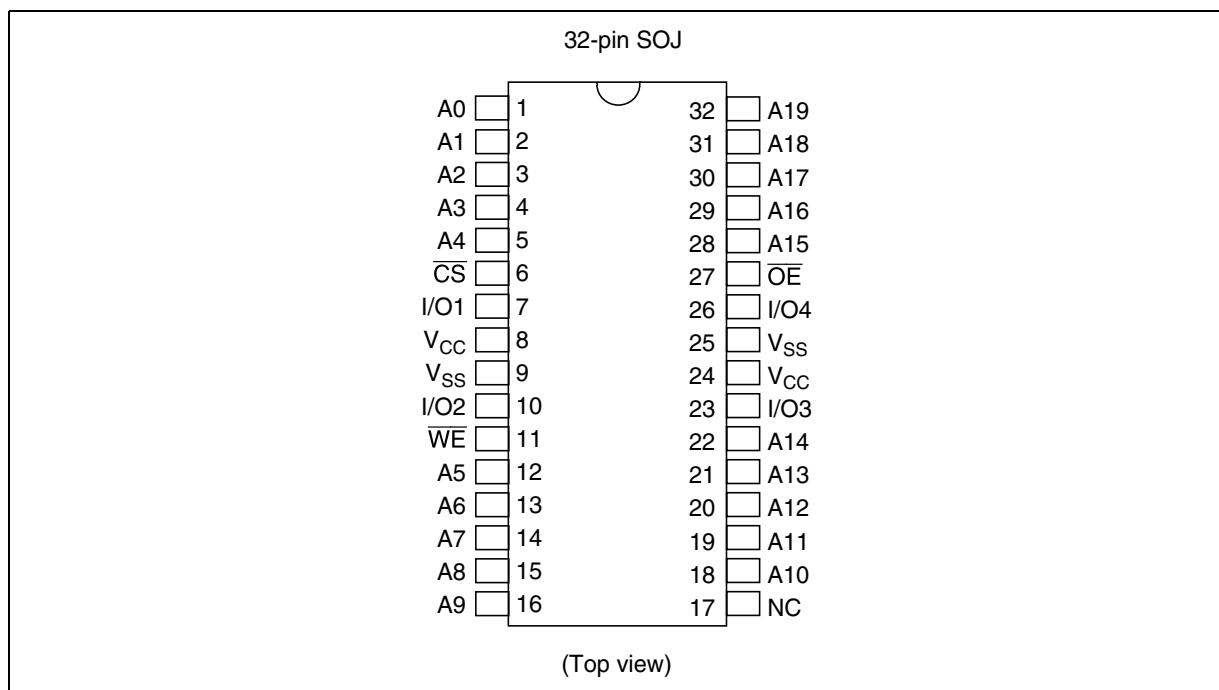

Pin Description

Pin name	Function
A0 to A19	Address input
I/O1 to I/O4	Data input/output
\overline{CS}	Chip select
\overline{OE}	Output enable
\overline{WE}	Write enable
V_{CC}	Power supply
V_{SS}	Ground
NC	No connection

Block Diagram

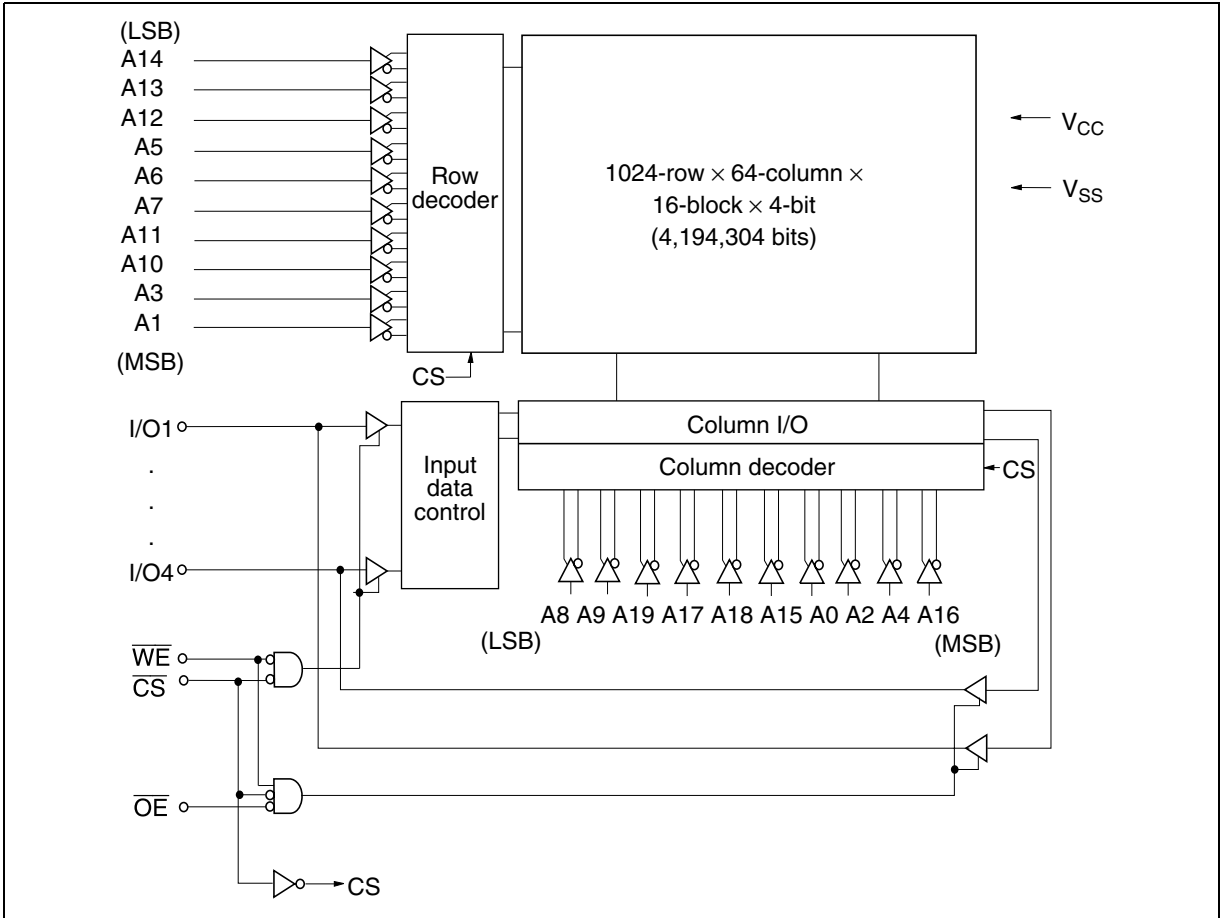

Operation Table

\overline{CS}	\overline{OE}	\overline{WE}	Mode	V_{CC} current	I/O	Ref. cycle
H	×	×	Standby	I_{SB1}, I_{SB1}	High-Z	—
L	H	H	Output disable	I_{CC}	High-Z	—
L	L	H	Read	I_{CC}	Dout	Read cycle (1) to (3)
L	H	L	Write	I_{CC}	Din	Write cycle (1)
L	L	L	Write	I_{CC}	Din	Write cycle (2)

Note: H: V_{IH} , L: V_{IL} , ×: V_{IH} or V_{IL}

Absolute Maximum Ratings

Parameter	Symbol	Value	Unit
Supply voltage relative to V_{SS}	V_{CC}	-0.5 to +4.6	V
Voltage on any pin relative to V_{SS}	V_T	-0.5*1 to $V_{CC}+0.5^{*2}$	V
Power dissipation	P_T	1.0	W
Operating temperature	T_{opr}	0 to +70	°C
Storage temperature	T_{stg}	-55 to +125	°C
Storage temperature under bias	T_{bias}	-10 to +85	°C

Notes: 1. V_T (min) = -2.0 V for pulse width (under shoot) \leq 6 ns.

2. V_T (max) = $V_{CC} + 2.0$ V for pulse width (over shoot) \leq 6 ns.

Recommended DC Operating Conditions

($T_a = 0$ to +70°C)

Parameter	Symbol	Min	Typ	Max	Unit
Supply voltage	V_{CC}^{*3}	3.0	3.3	3.6	V
	V_{SS}^{*4}	0	0	0	V
Input voltage	V_{IH}^{*4}	2.0	—	$V_{CC} + 0.5^{*2}$	V
	V_{IL}	-0.5*1	—	0.8	V

Notes: 1. V_{IL} (min) = -2.0 V for pulse width (under shoot) \leq 6 ns.

2. V_{IH} (max) = $V_{CC} + 2.0$ V for pulse width (over shoot) \leq 6 ns.

3. The supply voltage with all V_{CC} pins must be on the same level.

4. The supply voltage with all V_{SS} pins must be on the same level.

DC Characteristics

(Ta = 0 to +70°C, V_{CC} = 3.3 V ± 0.3 V, V_{SS} = 0V)

Parameter	Symbol	Min	Typ ^{*1}	Max	Unit	Test conditions
Input leakage current	I _{LI}	—	—	2	μA	V _{in} = V _{SS} to V _{CC}
Output leakage current	I _{LO}	—	—	2	μA	V _{in} = V _{SS} to V _{CC}
Operation power supply current	10 ns cycle I _{CC}	—	—	115	mA	Min cycle CS = V _{IL} , I _{out} = 0 mA Other inputs = V _{IH} /V _{IL}
	12 ns cycle I _{CC}	—	—	100	mA	
Standby power supply current	I _{SB}	—	—	40	mA	Min cycle, CS = V _{IH} , Other inputs = V _{IH} /V _{IL}
	I _{SB1}	—	2.5	5	mA	f = 0 MHz V _{CC} ≥ CS ≥ V _{CC} - 0.2 V, (1) 0 V ≤ V _{in} ≤ 0.2 V or (2) V _{CC} ≥ V _{in} ≥ V _{CC} - 0.2 V
		— ^{*2}	0.5 ^{*2}	1 ^{*2}		
Output voltage	V _{OL}	—	—	0.4	V	I _{OL} = 8 mA
	V _{OH}	2.4	—	—	V	I _{OH} = -4 mA

- Notes: 1. Typical values are at V_{CC} = 3.3 V, Ta = +25°C and not guaranteed.
2. This characteristics is guaranteed only for L-version.

Capacitance

(Ta = +25°C, f = 1.0 MHz)

Parameter	Symbol	Min	Typ	Max	Unit	Test conditions
Input capacitance ^{*1}	C _{in}	—	—	6	pF	V _{in} = 0 V
Input/output capacitance ^{*1}	C _{I/O}	—	—	8	pF	V _{I/O} = 0 V

- Note: 1. This parameter is sampled and not 100% tested.

AC Characteristics

($T_a = 0$ to $+70^\circ\text{C}$, $V_{CC} = 3.3\text{ V} \pm 0.3\text{ V}$, unless otherwise noted.)

Test Conditions

- Input pulse levels: 3.0 V/0.0 V
- Input rise and fall time: 3 ns
- Input and output timing reference levels: 1.5 V
- Output load: See figures (Including scope and jig)

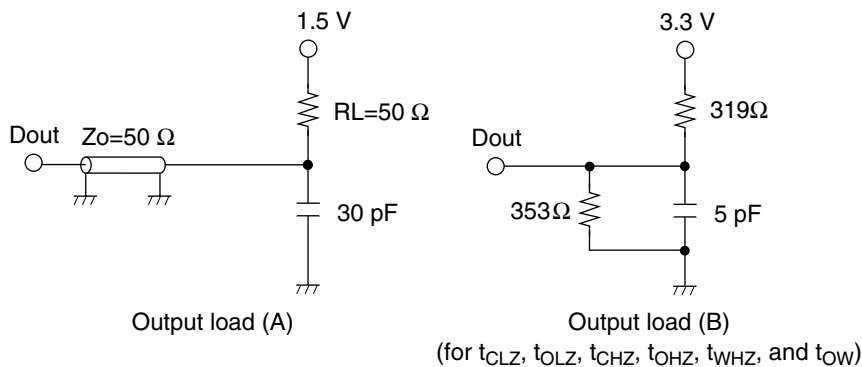

Read Cycle

Parameter	Symbol	HM62W4100HC				Unit	Notes
		-10		-12			
		Min	Max	Min	Max		
Read cycle time	t_{RC}	10	—	12	—	ns	
Address access time	t_{AA}	—	10	—	12	ns	
Chip select access time	t_{ACS}	—	10	—	12	ns	
Output enable to output valid	t_{OE}	—	5	—	6	ns	
Output hold from address change	t_{OH}	3	—	3	—	ns	
Chip select to output in low-Z	t_{CLZ}	3	—	3	—	ns	1
Output enable to output in low-Z	t_{OLZ}	0	—	0	—	ns	1
Chip deselect to output in high-Z	t_{CHZ}	—	5	—	6	ns	1
Output disable to output in high-Z	t_{OHZ}	—	5	—	6	ns	1

Write Cycle

Parameter	Symbol	HM62W4100HC				Unit	Notes
		-10		-12			
		Min	Max	Min	Max		
Write cycle time	t_{WC}	10	—	12	—	ns	
Address valid to end of write	t_{AW}	7	—	8	—	ns	
Chip select to end of write	t_{CW}	7	—	8	—	ns	9
Write pulse width	t_{WP}	7	—	8	—	ns	8
Address setup time	t_{AS}	0	—	0	—	ns	6
Write recovery time	t_{WR}	0	—	0	—	ns	7
Data to write time overlap	t_{DW}	5	—	6	—	ns	
Data hold from write time	t_{DH}	0	—	0	—	ns	
Write disable to output in low-Z	t_{OW}	3	—	3	—	ns	1
Output disable to output in high-Z	t_{OHZ}	—	5	—	6	ns	1
Write enable to output in high-Z	t_{WHZ}	—	5	—	6	ns	1

- Note:
1. Transition is measured ± 200 mV from steady voltage with output load (B). This parameter is sampled and not 100% tested.
 2. Address should be valid prior to or coincident with \overline{CS} transition low.
 3. \overline{WE} and/or \overline{CS} must be high during address transition time.
 4. If \overline{CS} and \overline{OE} are low during this period, I/O pins are in the output state. Then, the data input signals of opposite phase to the outputs must not be applied to them.
 5. If the \overline{CS} low transition occurs simultaneously with the \overline{WE} low transition or after the \overline{WE} transition, output remains a high impedance state.
 6. t_{AS} is measured from the latest address transition to the later of \overline{CS} or \overline{WE} going low.
 7. t_{WR} is measured from the earlier of \overline{CS} or \overline{WE} going high to the first address transition.
 8. A write occurs during the overlap of a low \overline{CS} and a low \overline{WE} . A write begins at the latest transition among \overline{CS} going low and \overline{WE} going low. A write ends at the earliest transition among \overline{CS} going high and \overline{WE} going high. t_{WP} is measured from the beginning of write to the end of write.
 9. t_{CW} is measured from the later of \overline{CS} going low to the end of write.

Timing Waveforms

Read Timing Waveform (1) ($\overline{WE} = V_{IH}$)

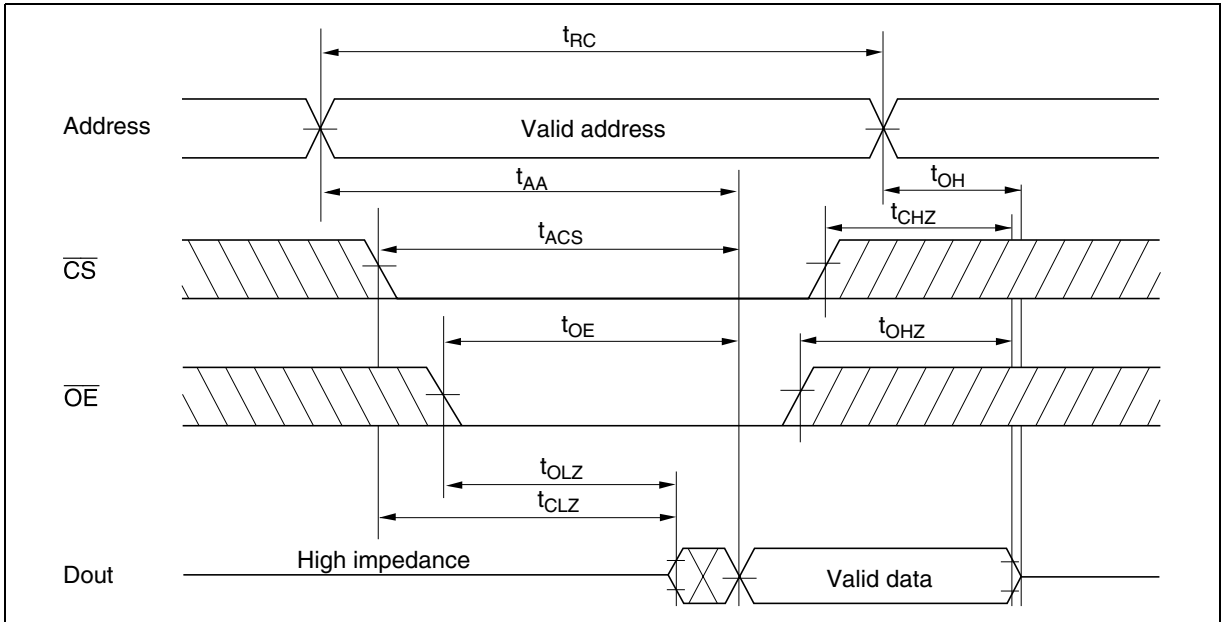

Read Timing Waveform (2) ($\overline{WE} = V_{IH}$, $\overline{CS} = V_{IL}$, $\overline{OE} = V_{IL}$)

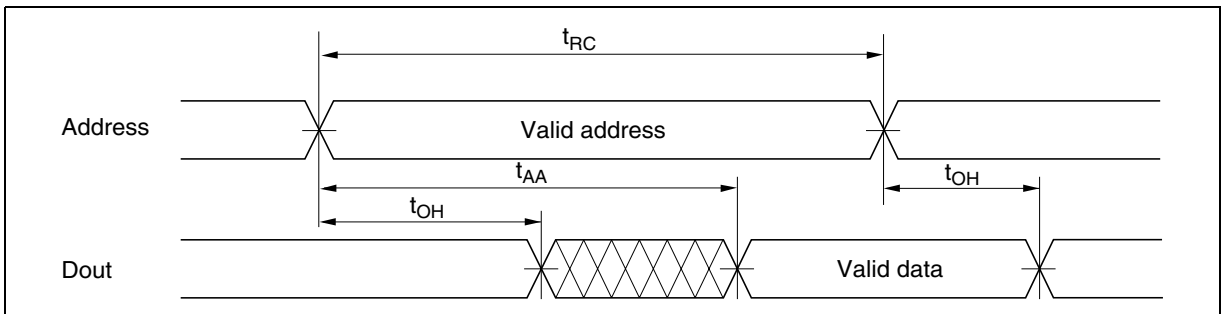

Read Timing Waveform (3) ($\overline{WE} = V_{IH}, \overline{CS} = V_{IL}, \overline{OE} = V_{IL}$)*2

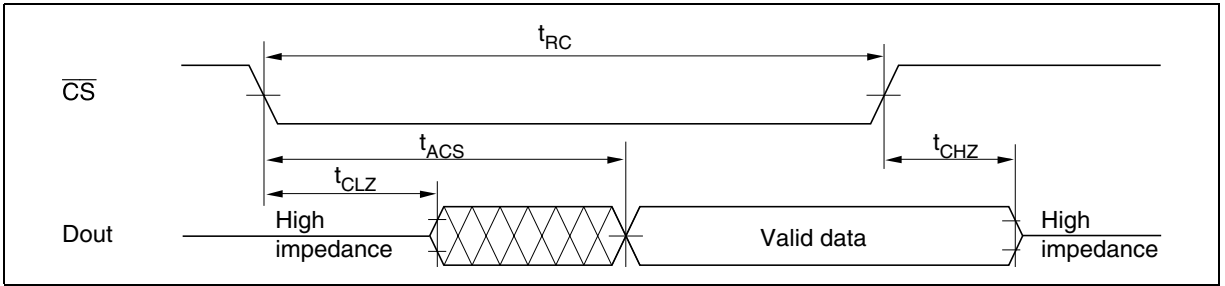

Write Timing Waveform (1) (\overline{WE} Controlled)

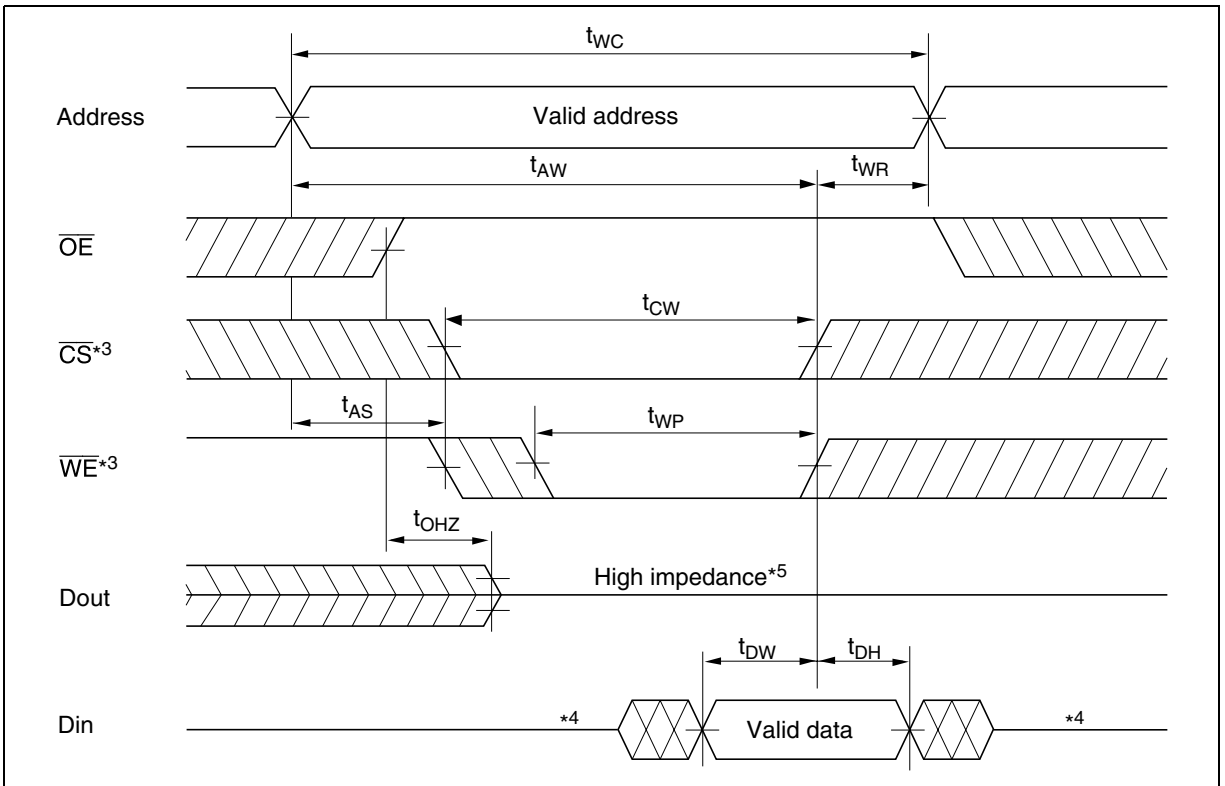

HM62W4100HC Series

Write Timing Waveform (2) (\overline{CS} Controlled)

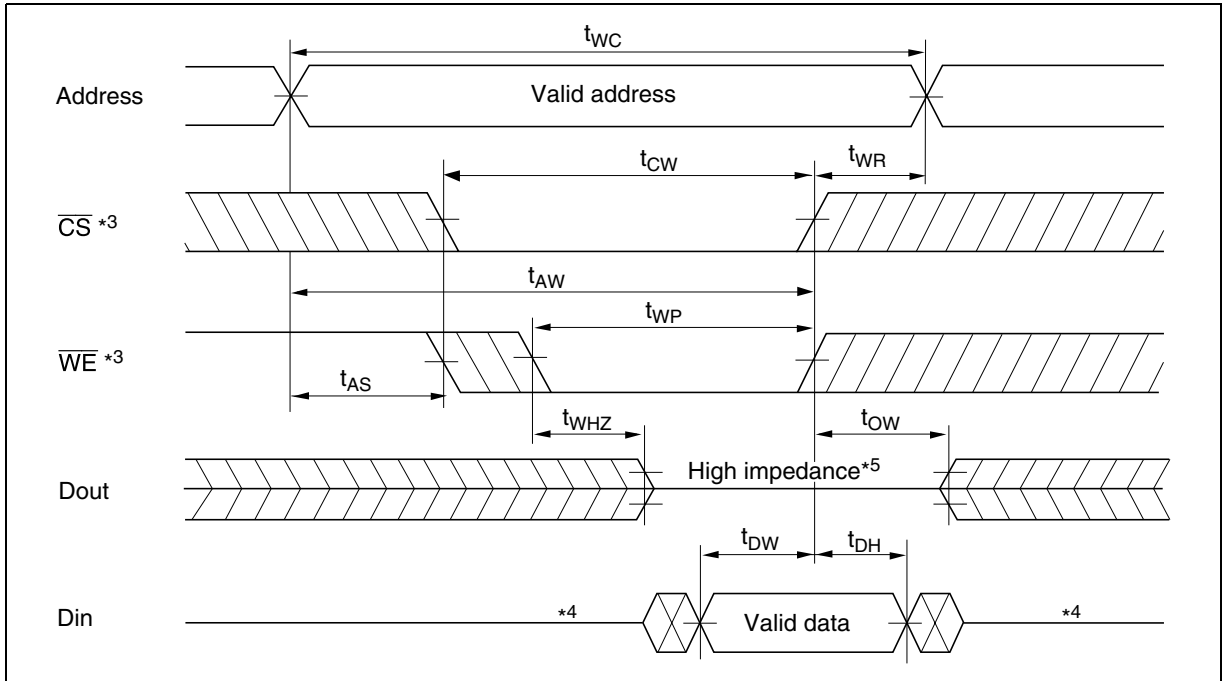

Low V_{CC} Data Retention Characteristics

($T_a = 0$ to $+70^\circ\text{C}$)

This characteristics is guaranteed only for L-version.

Parameter	Symbol	Min	Typ* ¹	Max	Unit	Test conditions
V_{CC} for data retention	V_{DR}	2.0	—	—	V	$V_{CC} \geq \overline{CS} \geq V_{CC} - 0.2$ V (1) $0 \text{ V} \leq V_{in} \leq 0.2 \text{ V}$ or (2) $V_{CC} \geq V_{in} \geq V_{CC} - 0.2 \text{ V}$
Data retention current	I_{CCDR}	—	300	600	μA	$V_{CC} = 3 \text{ V}$, $V_{CC} \geq \overline{CS} \geq V_{CC} - 0.2 \text{ V}$ (1) $0 \text{ V} \leq V_{in} \leq 0.2 \text{ V}$ or (2) $V_{CC} \geq V_{in} \geq V_{CC} - 0.2 \text{ V}$
Chip deselect to data retention time	t_{CDR}	0	—	—	ns	See retention waveform
Operation recovery time	t_R	5	—	—	ms	

Note: 1. Typical values are at $V_{CC} = 3.0 \text{ V}$, $T_a = +25^\circ\text{C}$, and not guaranteed.

Low V_{CC} Data Retention Timing Waveform

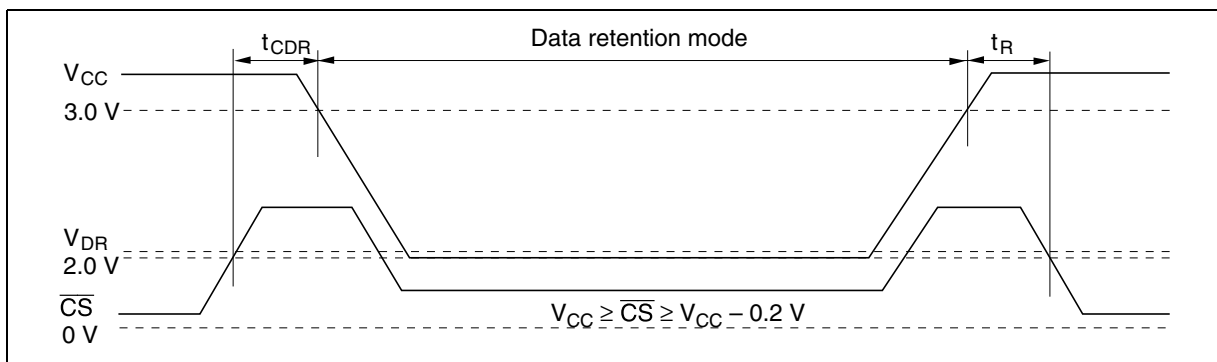

HM62W4100HC Series

Package Dimensions

HM62W4100HCJP/HCLJP Series (CP-32DB)

As of January, 2001

Unit: mm

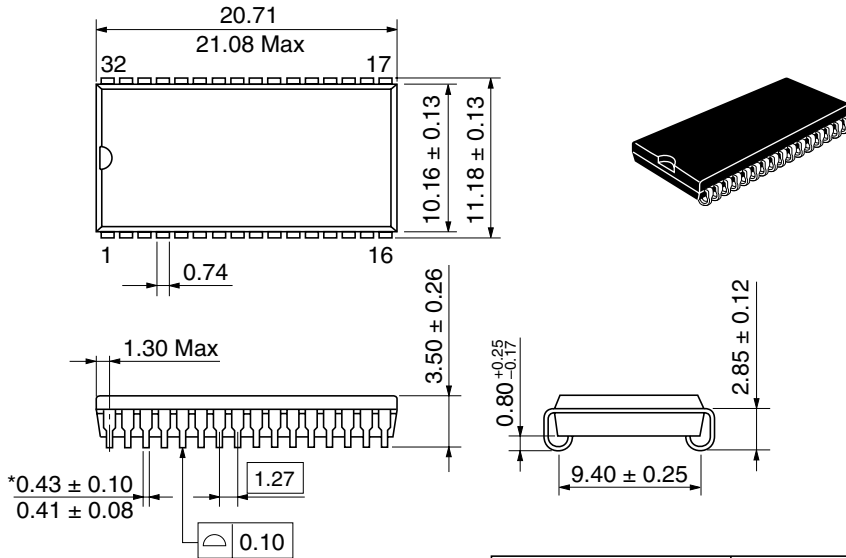

*Dimension including the plating thickness
Base material dimension

Hitachi Code	CP-32DB
JEDEC	Conforms
EIAJ	Conforms
Mass (reference value)	1.2 g

Disclaimer

1. Hitachi neither warrants nor grants licenses of any rights of Hitachi's or any third party's patent, copyright, trademark, or other intellectual property rights for information contained in this document. Hitachi bears no responsibility for problems that may arise with third party's rights, including intellectual property rights, in connection with use of the information contained in this document.
2. Products and product specifications may be subject to change without notice. Confirm that you have received the latest product standards or specifications before final design, purchase or use.
3. Hitachi makes every attempt to ensure that its products are of high quality and reliability. However, contact Hitachi's sales office before using the product in an application that demands especially high quality and reliability or where its failure or malfunction may directly threaten human life or cause risk of bodily injury, such as aerospace, aeronautics, nuclear power, combustion control, transportation, traffic, safety equipment or medical equipment for life support.
4. Design your application so that the product is used within the ranges guaranteed by Hitachi particularly for maximum rating, operating supply voltage range, heat radiation characteristics, installation conditions and other characteristics. Hitachi bears no responsibility for failure or damage when used beyond the guaranteed ranges. Even within the guaranteed ranges, consider normally foreseeable failure rates or failure modes in semiconductor devices and employ systemic measures such as fail-safes, so that the equipment incorporating Hitachi product does not cause bodily injury, fire or other consequential damage due to operation of the Hitachi product.
5. This product is not designed to be radiation resistant.
6. No one is permitted to reproduce or duplicate, in any form, the whole or part of this document without written approval from Hitachi.
7. Contact Hitachi's sales office for any questions regarding this document or Hitachi semiconductor products.

Sales Offices

HITACHI

Hitachi, Ltd.

Semiconductor & Integrated Circuits
 Nippon Bldg., 2-6-2, Ohte-machi, Chiyoda-ku, Tokyo 100-0004, Japan
 Tel: (03) 3270-2111 Fax: (03) 3270-5109

URL <http://www.hitachisemiconductor.com/>

For further information write to:

Hitachi Semiconductor (America) Inc.
 179 East Tasman Drive
 San Jose, CA 95134
 Tel: <1>(408) 433-1990
 Fax: <1>(408) 433-0223

Hitachi Europe Ltd.
 Electronic Components Group
 Whitebrook Park
 Lower Cookham Road
 Maidenhead
 Berkshire SL6 8YA, United Kingdom
 Tel: <44> (1628) 585000
 Fax: <44> (1628) 585200

Hitachi Europe GmbH
 Electronic Components Group
 Dornacher Straße 3
 D-85622 Feldkirchen
 Postfach 201, D-85619 Feldkirchen
 Germany
 Tel: <49> (89) 9 9180-0
 Fax: <49> (89) 9 29 30 00

Hitachi Asia Ltd.
 Hitachi Tower
 16 Collyer Quay #20-00
 Singapore 049318
 Tel: <65>-538-6533/538-8577
 Fax: <65>-538-6933/538-3877
 URL: <http://semiconductor.hitachi.com.sg>

Hitachi Asia Ltd.
 (Taipei Branch Office)
 4/F, No. 167, Tun Hwa North Road
 Hung-Kuo Building
 Taipei (105), Taiwan
 Tel: <886>-(2)-2718-3666
 Fax: <886>-(2)-2718-8180
 Telex: 23222 HAS-TP
 URL: <http://www.hitachi.com.tw>

Hitachi Asia (Hong Kong) Ltd.
 Group III (Electronic Components)
 7/F., North Tower
 World Finance Centre,
 Harbour City, Canton Road
 Tsim Sha Tsui, Kowloon Hong Kong
 Tel: <852>-(2)-735-9218
 Fax: <852>-(2)-730-0281
 URL: <http://semiconductor.hitachi.com.hk>

Copyright © Hitachi, Ltd., 2001. All rights reserved. Printed in Japan.
 Colophon 5.0