

**Silicon Tuning Diode**

- High Q hyperabrupt tuning diode
- Designed for low tuning voltage operation
- For VCO's in mobile communications equipment

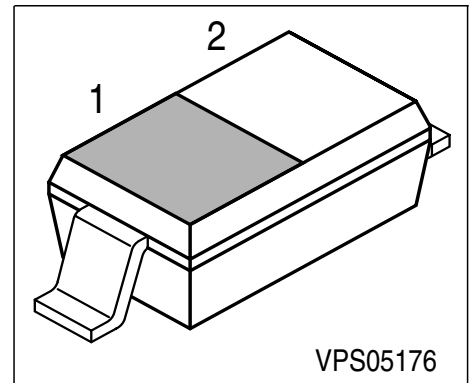

Type	Marking	Pin Configuration		Package
BBY 51-03W	H	1 = C	2 = A	SOD-323

**Maximum Ratings**

Parameter	Symbol	Value	Unit
Diode reverse voltage	$V_R$	7	V
Forward current	$I_F$	20	mA
Operating temperature range	$T_{op}$	-55 ... 150	°C
Storage temperature	$T_{stg}$	-55 ... 150	

**Electrical Characteristics** at  $T_A = 25^\circ\text{C}$ , unless otherwise specified.

Parameter	Symbol	Values			Unit
		min.	typ.	max.	
<b>DC characteristics</b>					
Reverse current $V_R = 6\text{ V}$	$I_R$	-	-	10	nA
Reverse current $V_R = 6\text{ V}, T_A = 150^\circ\text{C}$	$I_R$	-	-	100	
<b>AC characteristics</b>					
Diode capacitance $V_R = 1\text{ V}, f = 1\text{ MHz}$ $V_R = 2\text{ V}, f = 1\text{ MHz}$ $V_R = 3\text{ V}, f = 1\text{ MHz}$ $V_R = 4\text{ V}, f = 1\text{ MHz}$	$C_T$	4.5 3.4 2.7 2.5	5.3 4.2 3.5 3.1	6.1 5.2 4.6 3.7	pF
Capacitance ratio $V_R = 1\text{ V}, V_R = 4\text{ V}, f = 1\text{ MHz}$	$C_{T1}/C_{T4}$	1.55	1.75	2.2	-
Capacitance difference $V_R = 1\text{ V}, V_R = 3\text{ V}, f = 1\text{ MHz}$	$C_{1V}-C_{3V}$	1.4	1.78	2.2	pF
Capacitance difference $V_R = 3\text{ V}, V_R = 4\text{ V}, f = 1\text{ MHz}$	$C_{3V}-C_{4V}$	0.3	0.5	0.7	
Series resistance $V_R = 1\text{ V}, f = 1\text{ GHz}$	$r_s$	-	0.37	-	$\Omega$
Case capacitance $f = 1\text{ MHz}$	$C_C$	-	0.12	-	pF
Series inductance	$L_s$	-	1.8	-	nH

Diode capacitance  $C_T = f(V_R)$   
 $f = 1\text{MHz}$

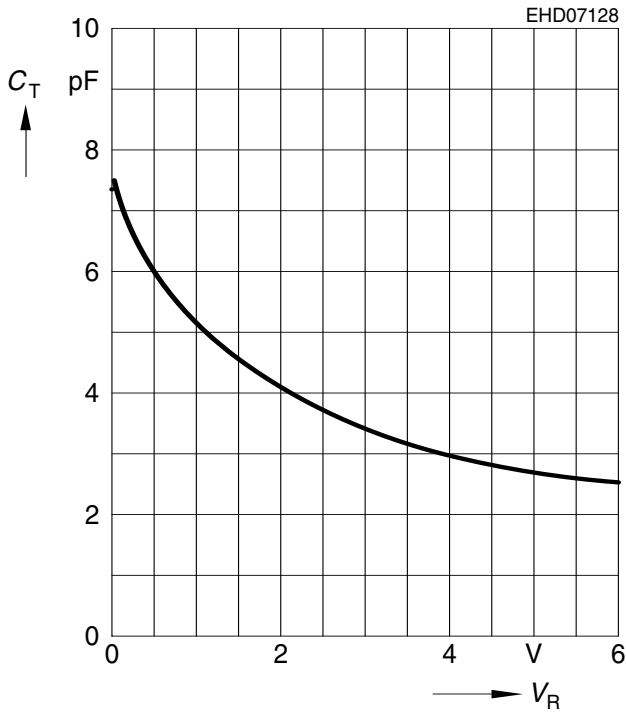

Temperature coefficient  $T_{CC} = f(V_R)$ ,  
per diode,  $f = 1\text{MHz}$

