

**NPN Silicon RF Transistor**

- Especially suitable for TV-sat and UHF tuners

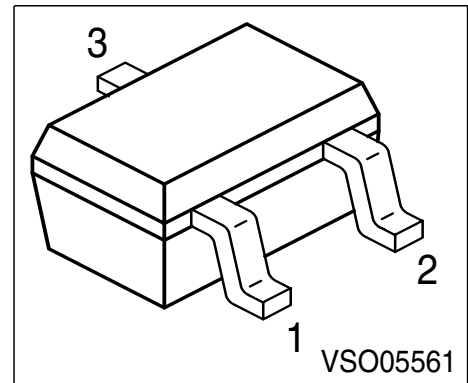

**ESD:** Electrostatic discharge sensitive device, observe handling precaution!

Type	Marking	Pin Configuration			Package
BF 775W	LOs	1 = B	2 = E	3 = C	SOT-323

**Maximum Ratings**

Parameter	Symbol	Value	Unit
Collector-emitter voltage	$V_{CEO}$	15	V
Collector-emitter voltage	$V_{CES}$	20	
Collector-base voltage	$V_{CBO}$	20	
Emitter-base voltage	$V_{EBO}$	2.5	
Collector current	$I_C$	30	mA
Base current	$I_B$	4	
Total power dissipation, $T_S \leq 86^\circ\text{C}$ (F)	$P_{tot}$	280	mW
Junction temperature	$T_j$	150	°C
Ambient temperature	$T_A$	-65 ... 150	
Storage temperature	$T_{stg}$	-65 ... 150	

**Thermal Resistance**

Junction - soldering point	$R_{thJS}$	$\leq 230$	K/W
----------------------------	------------	------------	-----

<sup>1</sup> $T_S$  is measured on the collector lead at the soldering point to the pcb

**Electrical Characteristics** at  $T_A = 25^\circ\text{C}$ , unless otherwise specified.

Parameter	Symbol	Values			Unit
		min.	typ.	max.	
<b>DC characteristics</b>					
Collector-emitter breakdown voltage $I_C = 1\text{ mA}, I_B = 0$	$V_{(BR)CEO}$	15	-	-	V
Collector-emitter cutoff current $V_{CE} = 20\text{ V}, V_{BE} = 0$	$I_{CES}$	-	-	10	$\mu\text{A}$
Collector-base cutoff current $V_{CB} = 10\text{ V}, I_E = 0$	$I_{CBO}$	-	-	100	nA
Emitter-base cutoff current $V_{EB} = 2.5\text{ V}, I_C = 0$	$I_{EBO}$	-	-	100	$\mu\text{A}$
DC current gain $I_C = 15\text{ mA}, V_{CE} = 8\text{ V}$	$h_{FE}$	40	100	200	-

**Electrical Characteristics** at  $T_A = 25^\circ\text{C}$ , unless otherwise specified.

Parameter	Symbol	Values			Unit
		min.	typ.	max.	
<b>AC characteristics</b> (verified by random sampling)					
Transition frequency $I_C = 15\text{ mA}$ , $V_{CE} = 8\text{ V}$ , $f = 500\text{ MHz}$	$f_T$	3.5	5	-	GHz
Collector-base capacitance $V_{CB} = 10\text{ V}$ , $f = 1\text{ MHz}$	$C_{cb}$	-	0.43	0.6	pF
Collector-emitter capacitance $V_{CE} = 10\text{ V}$ , $f = 1\text{ MHz}$	$C_{ce}$	-	0.25	-	
Emitter-base capacitance $V_{EB} = 0.5\text{ V}$ , $f = 1\text{ MHz}$	$C_{eb}$	-	0.7	-	
Noise figure $I_C = 2\text{ mA}$ , $V_{CE} = 6\text{ V}$ , $Z_S = Z_{\text{Sopt}}$ , $f = 900\text{ MHz}$ $f = 1.8\text{ GHz}$	$F$	-	1.8 2.9	-	dB
Power gain, maximum available <sup>1)</sup> $I_C = 15\text{ mA}$ , $V_{CE} = 8\text{ V}$ , $Z_S = Z_{\text{Sopt}}$ , $Z_L = Z_{\text{Lopt}}$ , $f = 900\text{ MHz}$ $f = 1.8\text{ GHz}$	$G_{\text{ma}}$	-	15.5 10	-	
Transducer gain $I_C = 15\text{ mA}$ , $V_{CE} = 8\text{ V}$ , $Z_S = Z_L = 50\Omega$ , $f = 900\text{ MHz}$ $f = 1.8\text{ GHz}$	$ S_{21e} ^2$	-	13 7.5	-	

$$^1G_{\text{ma}} = |S_{21} / S_{12}| (k - (k^2 - 1)^{1/2})$$