

NPN Silicon RF Transistor

Preliminary data

- For high gain low noise amplifiers
- Smallest Package 1.4 x 0.8 x 0.59mm
- Noise figure $F = 1.1$ dB at 1.8 GHz
outstanding $G_{ma} = 20$ dB at 1.8 GHz
- Transition frequency $f_T = 25$ GHz
- Gold metallization for high reliability
- **SIEGET® 25 GHz f_T - Line**

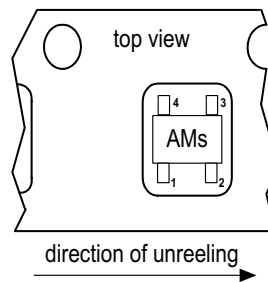
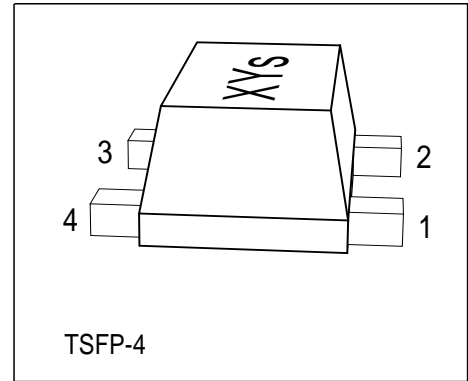

ESD: Electrostatic discharge sensitive device, observe handling precaution!

Type	Marking	Pin Configuration				Package
BFP420F	AMs	1 = B	2 = E	3 = C	4 = E	TSFP-4

Maximum Ratings

Parameter	Symbol	Value	Unit
Collector-emitter voltage	V_{CEO}	4.5	V
Collector-base voltage	V_{CBO}	15	
Emitter-base voltage	V_{EBO}	1.5	
Collector current	I_C	35	mA
Base current	I_B	3	
Total power dissipation $T_S \leq 111^\circ\text{C}^1)$	P_{tot}	160	mW
Junction temperature	T_j	150	$^\circ\text{C}$
Ambient temperature	T_A	-65 ... 150	
Storage temperature	T_{stg}	-65 ... 150	

Thermal Resistance

Junction - soldering point ²⁾	R_{thJS}	≤ 240	K/W
--	------------	------------	-----

¹ T_S is measured on the emitter lead at the soldering point to the pcb

² For calculation of R_{thJA} please refer to Application Note Thermal Resistance

Electrical Characteristics at $T_A = 25^\circ\text{C}$, unless otherwise specified.

Parameter	Symbol	Values			Unit
		min.	typ.	max.	
DC characteristics					
Collector-emitter breakdown voltage $I_C = 1 \text{ mA}, I_B = 0$	$V_{(BR)CEO}$	4.5	5	-	V
Collector-base cutoff current $V_{CB} = 5 \text{ V}, I_E = 0$	I_{CBO}	-	-	200	nA
Emitter-base cutoff current $V_{EB} = 1.5 \text{ V}, I_C = 0$	I_{EBO}	-	-	35	μA
DC current gain $I_C = 20 \text{ mA}, V_{CE} = 4 \text{ V}$	h_{FE}	50	80	150	-
AC characteristics (verified by random sampling)					
Transition frequency $I_C = 30 \text{ mA}, V_{CE} = 3 \text{ V}, f = 2 \text{ GHz}$	f_T	18	25	-	GHz
Collector-base capacitance $V_{CB} = 2 \text{ V}, f = 1 \text{ MHz}$	C_{cb}	-	0.15	0.3	pF
Collector-emitter capacitance $V_{CE} = 2 \text{ V}, f = 1 \text{ MHz}$	C_{ce}	-	0.33	-	
Emitter-base capacitance $V_{EB} = 0.5 \text{ V}, f = 1 \text{ MHz}$	C_{eb}	-	0.5	-	
Noise figure $I_C = 5 \text{ mA}, V_{CE} = 2 \text{ V}, Z_S = Z_{Sopt}, f = 1.8 \text{ GHz}$	F	-	1.1	-	dB
Power gain, maximum available ¹⁾ $I_C = 20 \text{ mA}, V_{CE} = 2 \text{ V}, Z_S = Z_{Sopt}, Z_L = Z_{Lopt}, f = 1.8 \text{ GHz}$	G_{ma}	-	20	-	
Insertion power gain $I_C = 20 \text{ mA}, V_{CE} = 2 \text{ V}, f = 1.8 \text{ GHz}, Z_S = Z_L = 50\Omega$	$ S_{21} ^2$	-	17	-	
Third order intercept point at output ²⁾ $I_C = 20 \text{ mA}, V_{CE} = 2 \text{ V}, Z_S = Z_L = 50\Omega, f = 1.8 \text{ GHz}$	IP_3	-	24	-	dBm
1dB Compression point at output ³⁾ $I_C = 20 \text{ mA}, V_{CE} = 2 \text{ V}, f = 1.8 \text{ GHz}, Z_S = Z_L = 50\Omega$	P_{-1dB}	-	10.5	-	

$$^1 G_{ma} = |S_{21} / S_{12}| (k - (k^2 - 1)^{1/2})$$

²⁾IP3 value depends on termination of all intermodulation frequency components. Termination used for this measurement is 50 Ω from 0.1MHz to 6GHz.

³⁾DC current no input power

SPICE Parameters (Gummel-Poon Model, Berkley-SPICE 2G.6 Syntax) :

Transistor Chip Data

IS =	0.20045	fA	BF =	72.534	-	NF =	1.2432	-
VAF =	28.383	V	IKF =	0.48731	A	ISE =	19.049	fA
NE =	2.0518	-	BR =	7.8287	-	NR =	1.3325	-
VAR =	19.705	V	IKR =	0.69141	A	ISC =	0.019237	fA
NC =	1.1724	-	RB =	8.5757	Ω	IRB =	0.72983	mA
RBM =	3.4849	Ω	RE =	0.31111		RC =	0.10105	Ω
CJE =	1.8063	fF	VJE =	0.8051	V	MJE =	0.46576	-
TF =	6.7661	ps	XTF =	0.42199	-	VTF =	0.23794	V
ITF =	1	mA	PTF =	0	deg	CJC =	234.53	fF
VJC =	0.81969	V	MJC =	0.30232	-	XCJC =	0.3	-
TR =	2.3249	ns	CJS =	0	F	VJS =	0.75	V
MJS =	0	-	XTB =	0	-	EG =	1.11	eV
XTI =	3	-	FC =	0.73234	-	TNOM	300	K

C'-E'-Diode Data (Berkley-SPICE 2G.6 Syntax) :

IS =	3.5	fA	N =	1.02	-	RS =	10	Ω
------	-----	----	-----	------	---	------	----	---

All parameters are ready to use, no scaling is necessary

Package Equivalent Circuit:

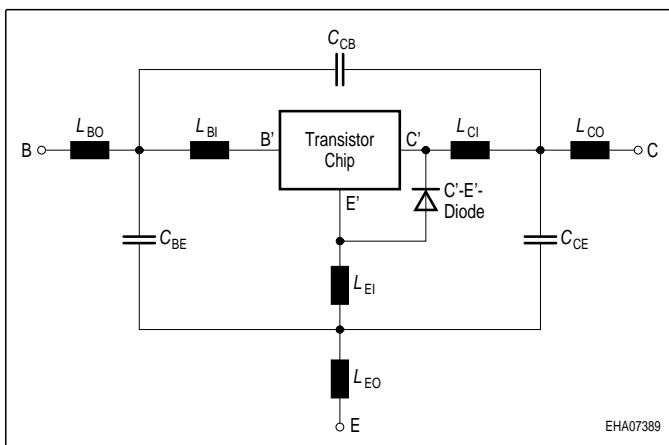

$L_{BO} =$	0.22	nH	$L_{BI} =$	0.42	nH
$L_{EO} =$	0.28	nH	$R_{LBI} =$	0.15	Ω
$L_{CO} =$	0.22	nH	$L_{EI} =$	0.26	nH
$K_{BO-EO} =$	0.10	-	$R_{LEI} =$	0.11	Ω
$K_{BO-CO} =$	0.01	-	$L_{CI} =$	0.35	nH
$K_{EO-CO} =$	0.11	-	$R_{LCI} =$	0.13	Ω
$C_{BE} =$	34	fF	$K_{CI-EI} =$	-0.05	-
$C_{BC} =$	2	fF	$K_{BI-CI} =$	-0.08	-
$C_{CE} =$	33	fF	$K_{BI-EI} =$	0.20	-

Valid up to 6GHz

The TSFP-4 package has two emitter leads. To avoid high complexity of the package equivalent circuit, both leads are combined in one electrical connection.

R_{Lx1} are series resistors for the inductances L_{x1} and K_{xa-yb} are the coupling coefficients between the inductances L_{xa} and L_{yb} . The reference pins for the coupled ports are B, E, C, B', E', C'.

For examples and ready to use parameters please contact your local Infineon Technologies distributor or sales office to obtain a Infineon Technologies CD-ROM or see Internet: <http://www.infineon.com/silicondiscretes>

For non-linear simulation:

- Use transistor chip parameters in Berkeley SPICE 2G.6 syntax for all simulators.
- If you need simulation of the reverse characteristics, add the diode with the C'-E'- diode data between collector and emitter.
- Simulation of package is not necessary for frequencies < 100MHz.
For higher frequencies add the wiring of package equivalent circuit around the non-linear transistor and diode model.

Note:

- This transistor is constructed in a common emitter configuration. This feature causes an additional reverse biased diode between emitter and collector, which does not effect normal operation.

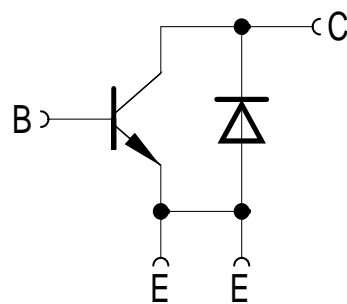

EHA07307

Transistor Schematic Diagram

The common emitter configuration shows the following advantages:

- Higher gain because of lower emitter inductance.
- Power is dissipated via the grounded emitter leads, because the chip is mounted on copper emitter leadframe.

Please note, that the broadest lead is the emitter lead.