

**NPN Silicon RF Transistor**
**Preliminary data**

- For highest gain low noise amplifier at 1.8 GHz

**Outstanding  $G_{ma} = 20$  dB**

**Noise Figure  $F = 0.9$  dB**

- Gold metallization for high reliability
- **SIEGET® 45 - Line**

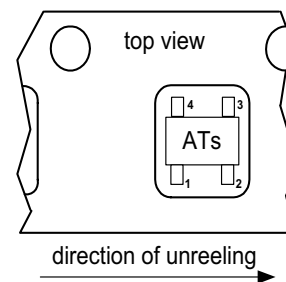
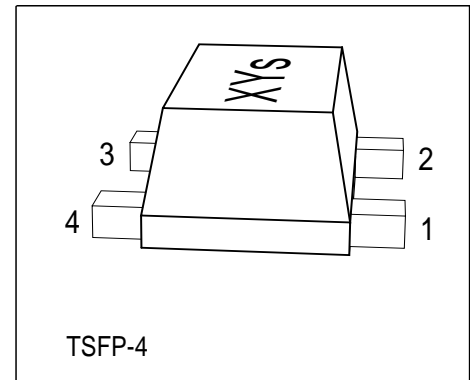

**ESD:** Electrostatic discharge sensitive device, observe handling precaution!

Type	Marking	Pin Configuration				Package
BFP540F	ATs	1 = B	2 = E	3 = C	4 = E	TSFP-4

**Maximum Ratings**

Parameter	Symbol	Value	Unit
Collector-emitter voltage	$V_{CEO}$	4.5	V
Collector-base voltage	$V_{CBO}$	14	
Emitter-base voltage	$V_{EBO}$	1	
Collector current	$I_C$	80	mA
Base current	$I_B$	8	
Total power dissipation $T_S \leq 82^\circ\text{C}$ 1)	$P_{tot}$	250	mW
Junction temperature	$T_j$	150	°C
Ambient temperature	$T_A$	-65 ... 150	
Storage temperature	$T_{stg}$	-65 ... 150	

**Thermal Resistance**

Junction - soldering point <sup>2)</sup>	$R_{thJS}$	$\leq 270$	K/W
--	------------	------------	-----

<sup>1</sup>  $T_S$  is measured on the emitter lead at the soldering point to the pcb

<sup>2</sup> For calculation of  $R_{thJA}$  please refer to Application Note Thermal Resistance

**Electrical Characteristics** at  $T_A = 25^\circ\text{C}$ , unless otherwise specified.

Parameter	Symbol	Values			Unit
		min.	typ.	max.	
<b>DC characteristics</b>					
Collector-emitter breakdown voltage $I_C = 1 \text{ mA}, I_B = 0$	$V_{(BR)CEO}$	4.5	5	6.5	V
Collector-base cutoff current $V_{CB} = 5 \text{ V}, I_E = 0$	$I_{CBO}$	-	-	200	nA
Emitter-base cutoff current $V_{EB} = 1 \text{ V}, I_C = 0$	$I_{EBO}$	-	-	70	$\mu\text{A}$
DC current gain $I_C = 20 \text{ mA}, V_{CE} = 3.5 \text{ V}$	$h_{FE}$	50	110	200	-
<b>AC Characteristics</b> (verified by random sampling)					
Transition frequency $I_C = 50 \text{ mA}, V_{CE} = 4 \text{ V}, f = 1 \text{ GHz}$	$f_T$	-	30	-	GHz
Collector-base capacitance $V_{CB} = 2 \text{ V}, f = 1 \text{ MHz}$	$C_{cb}$	-	0.14	-	pF
Collector-emitter capacitance $V_{CE} = 2 \text{ V}, f = 1 \text{ MHz}$	$C_{ce}$	-	0.3	-	
Emitter-base capacitance $V_{EB} = 0.5 \text{ V}, f = 1 \text{ MHz}$	$C_{eb}$	-	0.6	-	
Noise figure $I_C = 5 \text{ mA}, V_{CE} = 2 \text{ V}, Z_S = Z_{Sopt}, f = 1.8 \text{ GHz}$	$F$	-	0.9	1.4	dB
Power gain, maximum available <sup>1)</sup> $I_C = 20 \text{ mA}, V_{CE} = 2 \text{ V}, Z_S = Z_{Sopt}, Z_L = Z_{Lopt}, f = 1.8 \text{ GHz}$	$G_{ma}$	-	20	-	dBm
Insertion power gain $I_C = 20 \text{ mA}, V_{CE} = 2 \text{ V}, f = 1.8 \text{ GHz}, Z_S = Z_L = 50\Omega$	$ S_{21} ^2$	16	18	-	
Third order intercept point at output <sup>2)</sup> $V_{CE} = 2 \text{ V}, f = 1.8 \text{ GHz}, Z_S = Z_L = 50\Omega, I_C = 20 \text{ mA}$	$IP_3$	-	24.5	-	
1dB compression point at output <sup>3)</sup> $V_{CE} = 2 \text{ V}, f = 1.8 \text{ GHz}, Z_S = Z_L = 50\Omega, I_C = 20 \text{ mA}$	$P_{-1dB}$	-	11	-	

$$^1 G_{ma} = |S_{21} / S_{12}| (k \cdot (k^2 - 1))^{1/2}$$

<sup>2)</sup>IP3 value depends on termination of all intermodulation frequency components. Termination used for this measurement is 50 $\Omega$  from 0.1MHz to 6GHz

<sup>3)</sup>DC current at no input power

**SPICE Parameters (Gummel-Poon Model, Berkley-SPICE 2G.6 Syntax) :**

**Transistor Chip Data**

IS =	82.84	aA	BF =	107.5	-	NF =	1	-
VAF =	28.383	V	IKF =	0.48731	A	ISE =	11.15	pA
NE =	3.19	-	BR =	5.5	-	NR =	1	-
VAR =	19.705	V	IKR =	0.02	A	ISC =	19.237	aA
NC =	1.172	-	RB =	5.4	Ω	IRB =	0.72983	mA
RBM =	1.3	Ω	RE =	0.31111		RC =	4	Ω
CJE =	1.8063	fF	VJE =	0.8051	V	MJE =	0.46576	-
TF =	6.76	ps	XTF =	0.4219	-	VTF =	0.23794	V
ITF =	1	mA	PTF =	0	deg	CJC =	234	fF
VJC =	0.81969	V	MJC =	0.30232	-	XCJC =	0.3	-
TR =	2.324	ns	CJS =	0	fF	VJS =	0.75	V
MJS =	0	-	XTB =	0	-	EG =	1.11	eV
XTI =	3	-	FC =	0.73234	-	TNOM	300	K

All parameters are ready to use, no scaling is necessary

**Package Equivalent Circuit:**

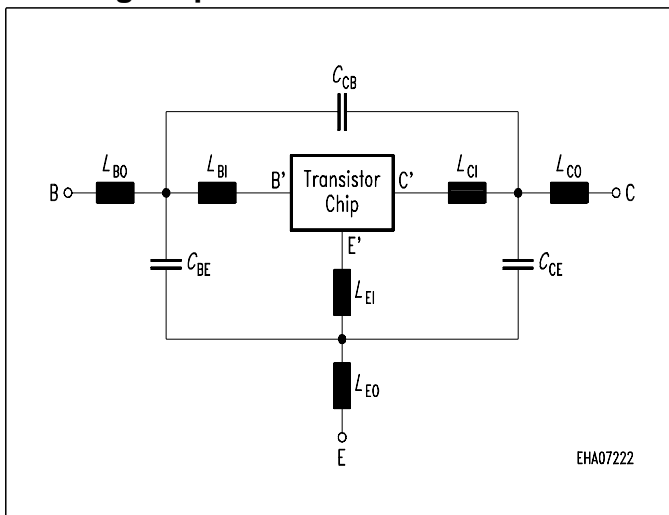

$L_{BO} =$	0.22	nH	$L_{BI} =$	0.42	nH
$L_{EO} =$	0.28	nH	$R_{LBI} =$	0.15	Ω
$L_{CO} =$	0.22	nH	$L_{EI} =$	0.26	nH
$K_{BO-EO} =$	0.10	-	$R_{LEI} =$	0.11	Ω
$K_{BO-CO} =$	0.01	-	$L_{CI} =$	0.35	nH
$K_{EO-CO} =$	0.11	-	$R_{LCI} =$	0.13	Ω
$C_{BE} =$	34	fF	$K_{CI-EI} =$	-0.05	-
$C_{BC} =$	2	fF	$K_{BI-CI} =$	-0.08	-
$C_{CE} =$	33	fF	$K_{BI-EI} =$	0.20	-

Valid up to 6GHz

The TSFP-4 package has two emitter leads. To avoid high complexity of the package equivalent circuit, both leads are combined in one electrical connection.

$R_{LxI}$  are series resistors for the inductances  $L_{xI}$  and  $K_{xa-yb}$  are the coupling coefficients between the inductances  $L_{xa}$  and  $L_{yb}$ . The referencepins for the coupled ports are B, E, C, B', E', C'.

For examples and ready to use parameters please contact your local Infineon Technologies distributor or sales office to obtain a Infineon Technologies CD-ROM or see Internet:  
<http://www.infineon.com/silicondiscretetes>