

NPN Silicon RF Transistor

- For broadband amplifiers up to 2 GHz and fast non-saturated switches at collector currents from 0.5 mA to 20 mA
- Complementary type: BFT 92W (PNP)

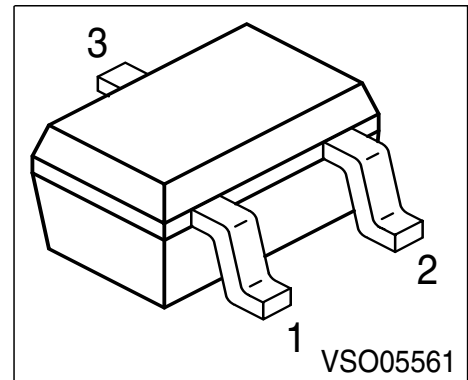

ESD: Electrostatic discharge sensitive device, observe handling precaution!

Type	Marking	Pin Configuration			Package
BFR 92W	P1s	1 = B	2 = E	3 = C	SOT-323

Maximum Ratings

Parameter	Symbol	Value	Unit
Collector-emitter voltage	V_{CEO}	15	V
Collector-emitter voltage	V_{CES}	20	
Collector-base voltage	V_{CBO}	20	
Emitter-base voltage	V_{EBO}	2.5	
Collector current	I_C	30	mA
Base current	I_B	4	
Total power dissipation, $T_S \leq 86^\circ\text{C}^F$	P_{tot}	280	mW
Junction temperature	T_j	150	°C
Ambient temperature	T_A	-65 ... 150	
Storage temperature	T_{stg}	-65 ... 150	

Thermal Resistance

Junction - soldering point	R_{thJS}	≤ 230	K/W
----------------------------	------------	------------	-----

¹ T_S is measured on the collector lead at the soldering point to the pcb

Electrical Characteristics at $T_A = 25^\circ\text{C}$, unless otherwise specified.

Parameter	Symbol	Values			Unit
		min.	typ.	max.	
DC characteristics					
Collector-emitter breakdown voltage $I_C = 1\text{ mA}, I_B = 0$	$V_{(BR)CEO}$	15	-	-	V
Collector-emitter cutoff current $V_{CE} = 20\text{ V}, V_{BE} = 0$	I_{CES}	-	-	10	μA
Collector-base cutoff current $V_{CB} = 10\text{ V}, I_E = 0$	I_{CBO}	-	-	100	nA
Emitter-base cutoff current $V_{EB} = 2.5\text{ V}, I_C = 0$	I_{EBO}	-	-	100	μA
DC current gain $I_C = 15\text{ mA}, V_{CE} = 8\text{ V}$	h_{FE}	40	100	200	-

Electrical Characteristics at $T_A = 25^\circ\text{C}$, unless otherwise specified.

Parameter	Symbol	Values			Unit
		min.	typ.	max.	
AC characteristics (verified by random sampling)					
Transition frequency $I_C = 15 \text{ mA}$, $V_{CE} = 8 \text{ V}$, $f = 500 \text{ MHz}$	f_T	3.5	5	-	GHz
Collector-base capacitance $V_{CB} = 10 \text{ V}$, $f = 1 \text{ MHz}$	C_{cb}	-	0.43	0.6	pF
Collector-emitter capacitance $V_{CE} = 10 \text{ V}$, $f = 1 \text{ MHz}$	C_{ce}	-	0.25	-	
Emitter-base capacitance $V_{EB} = 0.5 \text{ V}$, $f = 1 \text{ MHz}$	C_{eb}	-	0.7	-	
Noise figure $I_C = 2 \text{ mA}$, $V_{CE} = 6 \text{ V}$, $Z_S = Z_{\text{Sopt}}$, $f = 900 \text{ MHz}$ $f = 1.8 \text{ GHz}$	F	-	1.8 2.9	-	dB
Power gain, maximum available ^{F)} $I_C = 15 \text{ mA}$, $V_{CE} = 8 \text{ V}$, $Z_S = Z_{\text{Sopt}}$, $Z_L = Z_{\text{Lopt}}$, $f = 900 \text{ MHz}$ $f = 1.8 \text{ GHz}$	G_{ma}	-	15.5 10	-	
Transducer gain $I_C = 15 \text{ mA}$, $V_{CE} = 8 \text{ V}$, $Z_S = Z_L = 50\Omega$, $f = 900 \text{ MHz}$ $f = 1.8 \text{ GHz}$	$ S_{21e} ^2$	-	13 7.5	-	

$$^1G_{\text{ma}} = |S_{21} / S_{12}| (k - (k^2 - 1)^{1/2})$$

SPICE Parameters (Gummel-Poon Model, Berkley-SPICE 2G.6 Syntax) :

Transistor Chip Data

IS =	0.1213	fA	BF =	94.733	-	NF =	1.0947	-
VAF =	30	V	IKF =	0.46227	A	ISE =	129.55	fA
NE =	1.9052	-	BR =	10.729	-	NR =	0.8983	-
VAR =	14.599	V	IKR =	0.01	A	ISC =	0.75557	fA
NC =	1.371	-	RB =	14.998	Ω	IRB =	0.01652	mA
RBM =	7.8145	Ω	RE =	0.29088	Ω	RC =	0.13793	Ω
CJE =	10.416	fF	VJE =	0.70618	V	MJE =	0.34686	-
TF =	26.796	ps	XTF =	0.3817	-	VTF =	0.32861	V
ITF =	4.4601	mA	PTF =	0	deg	CJC =	946.47	fF
VJC =	0.84079	V	MJC =	0.4085	-	XCJC =	0.13464	-
TR =	1.2744	ns	CJS =	0	fF	VJS =	0.75	V
MJS =	0	-	XTB =	0	-	EG =	1.11	eV
XTI =	3	-	FC =	0.99545	-	TNOM	300	K

All parameters are ready to use, no scaling is necessary.
 Extracted on behalf of SIEMENS Small Signal Semiconductors by:
 Institut für Mobil-und Satellitentechnik (IMST)
 © 1996 SIEMENS AG

Package Equivalent Circuit:

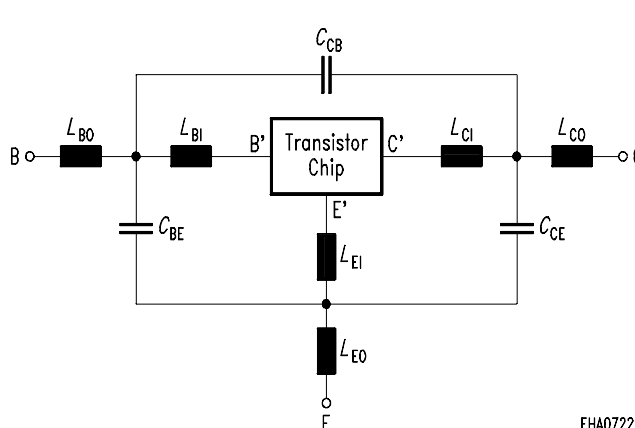

$L_{BI} =$	0.57	nH
$L_{BO} =$	0.4	nH
$L_{EI} =$	0.43	nH
$L_{EO} =$	0.5	nH
$L_{CI} =$	0	nH
$L_{CO} =$	0.41	nH
$C_{BE} =$	61	fF
$C_{CB} =$	101	fF
$C_{CE} =$	175	fF

Valid up to 6GHz

For examples and ready to use parameters please contact your local Infineon Technologies distributor or sales office to obtain a Infineon Technologies CD-ROM or see Internet: <http://www.infineon.com/products/discrete/index.htm>

Total power dissipation $P_{tot} = f(T_A^*, T_S)$

* Package mounted on epoxy

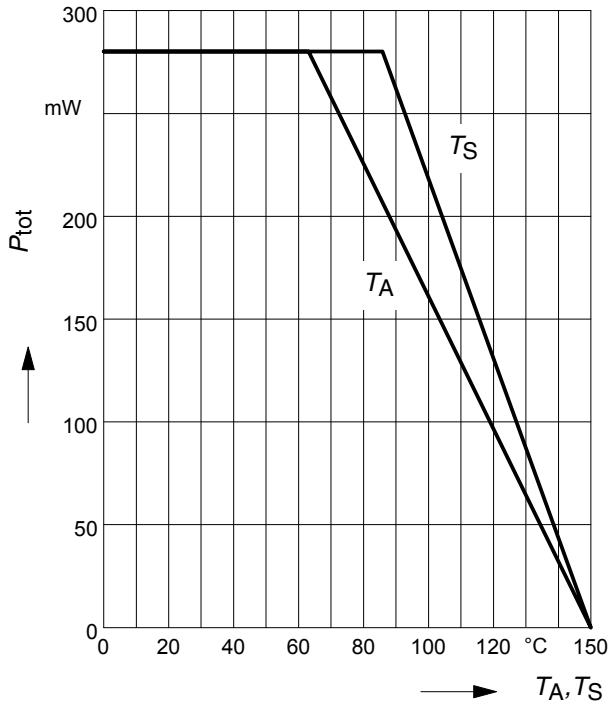

Permissible Pulse Load $R_{thJS} = f(t_p)$

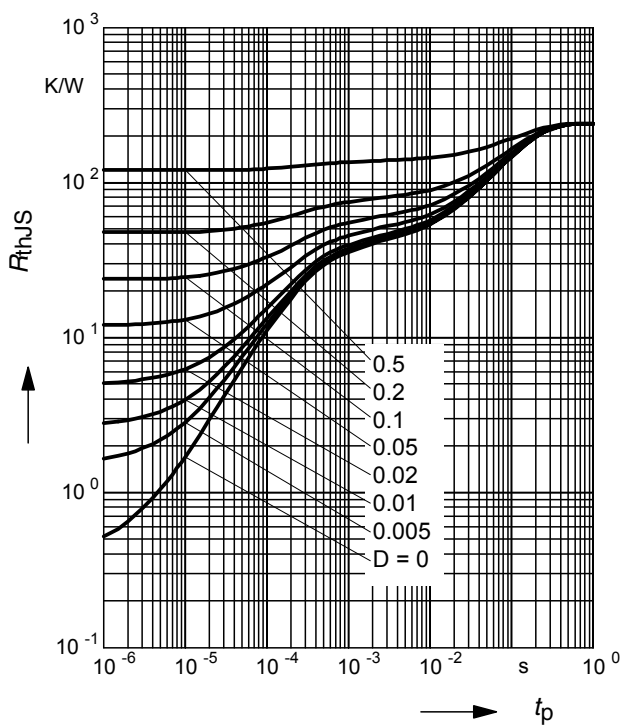

Permissible Pulse Load

$P_{totmax}/P_{totDC} = f(t_p)$

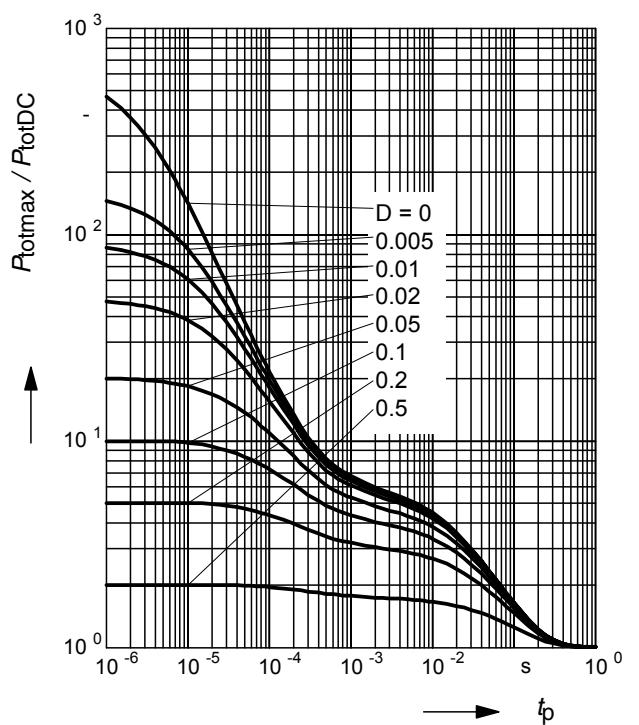

Collector-base capacitance $C_{cb} = f(V_{CB})$
 $f = 1\text{MHz}$

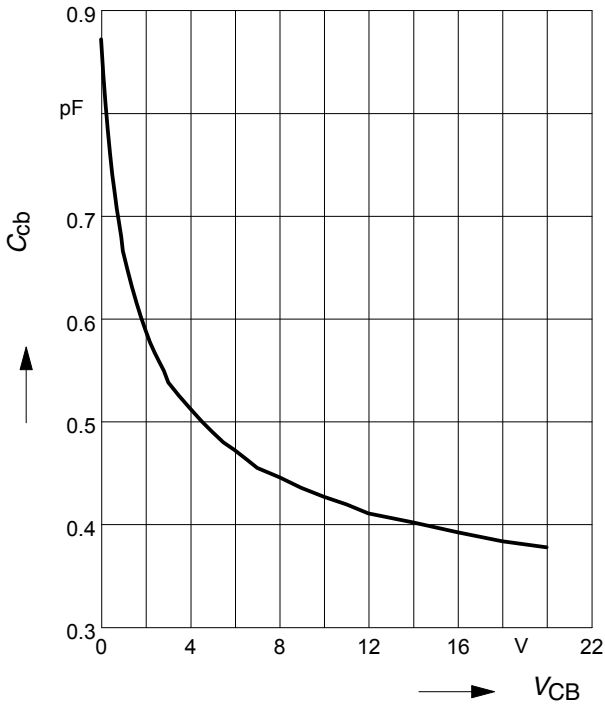

Transition frequency $f_T = f(I_C)$

$V_{CE} = \text{Parameter}$

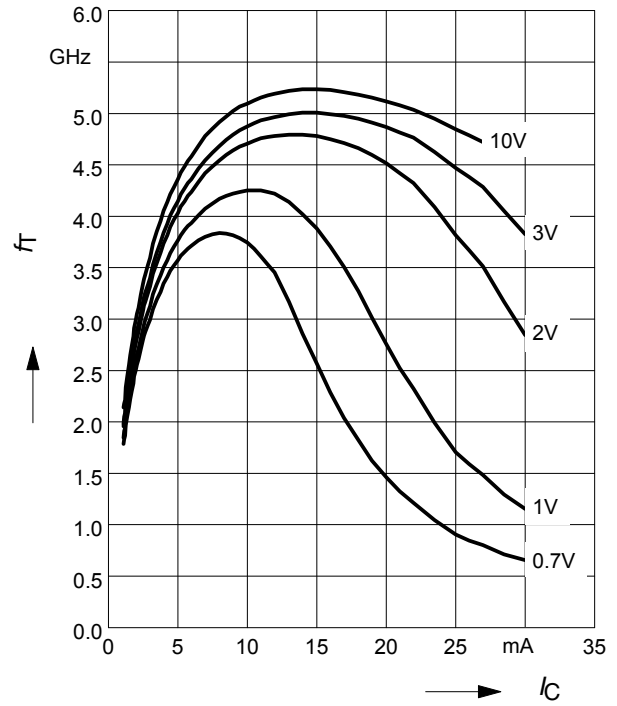

Power Gain $G_{ma}, G_{ms} = f(I_C)$

$f = 0.9\text{GHz}$

$V_{CE} = \text{Parameter}$

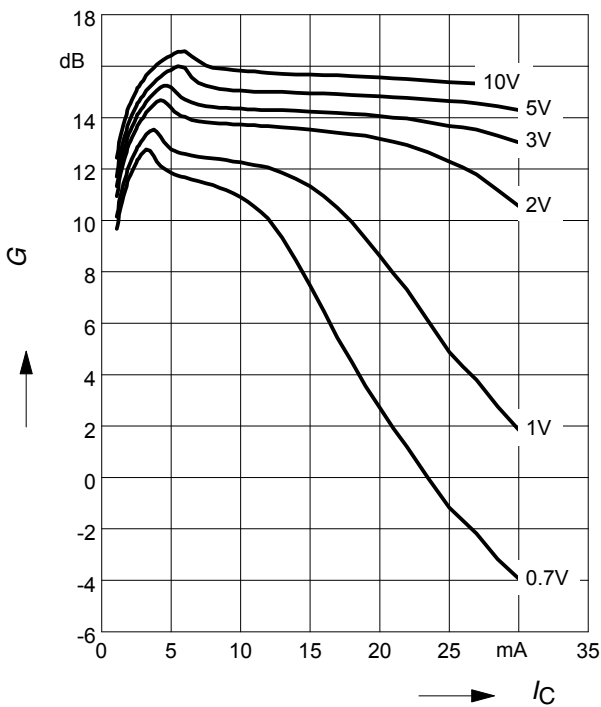

Power Gain $G_{ma}, G_{ms} = f(I_C)$

$f = 1.8\text{GHz}$

$V_{CE} = \text{Parameter}$

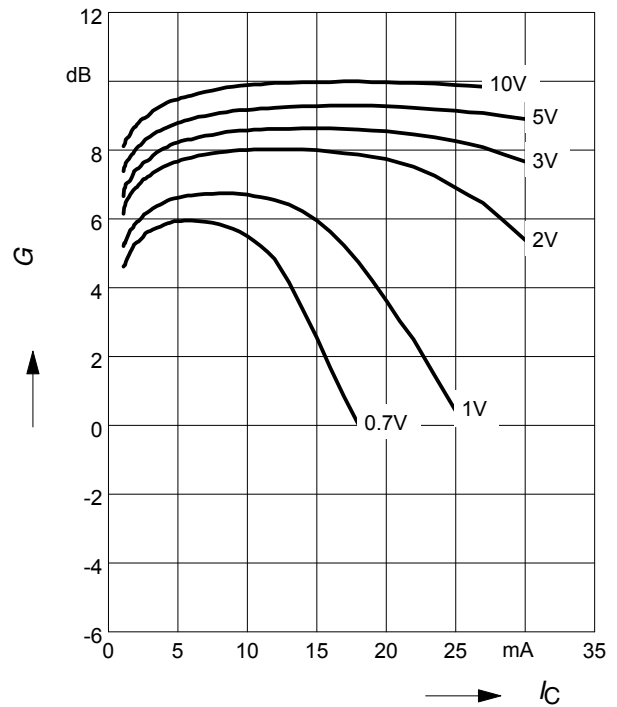

Power Gain $G_{ma}, G_{ms} = f(V_{CE})$:

$|S_{21}|^2 = f(V_{CE})$:

$f =$ Parameter

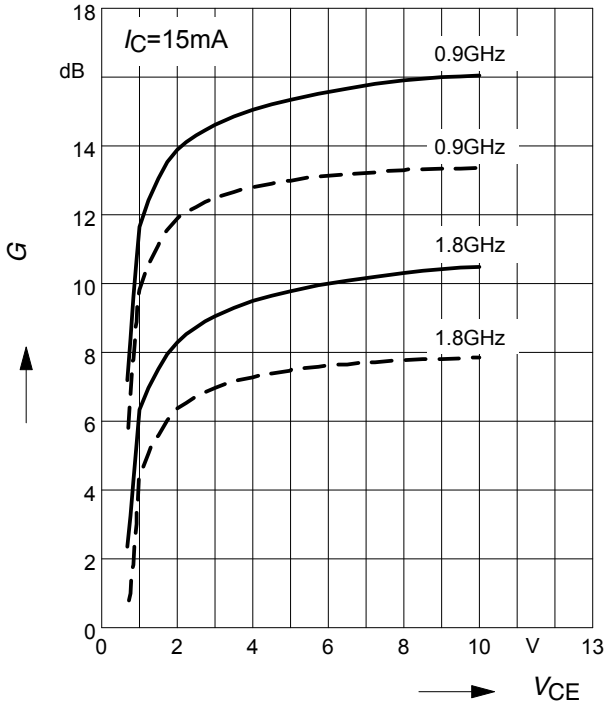

Intermodulation Intercept Point $IP_3 = f(I_C)$

(3rd order, Output, $Z_S = Z_L = 50\Omega$)

$V_{CE} =$ Parameter, $f = 900\text{MHz}$

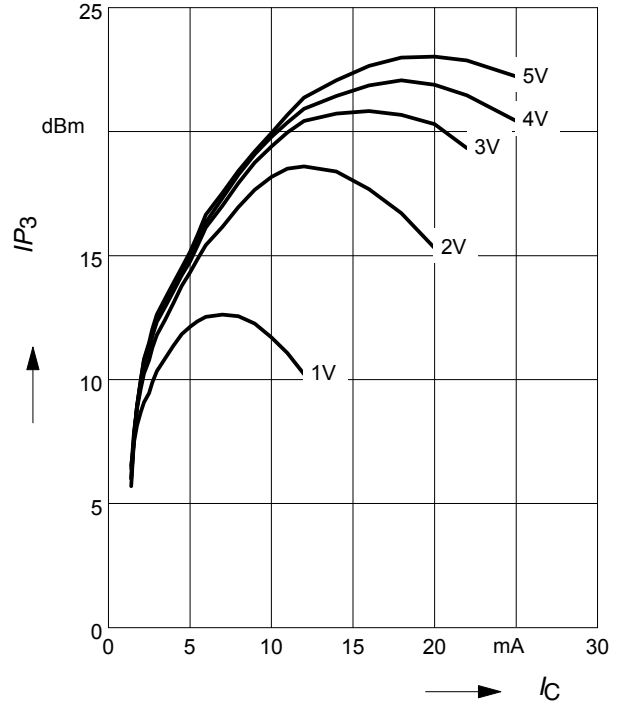

Power Gain $G_{ma}, G_{ms} = f(f)$

$V_{CE} =$ Parameter

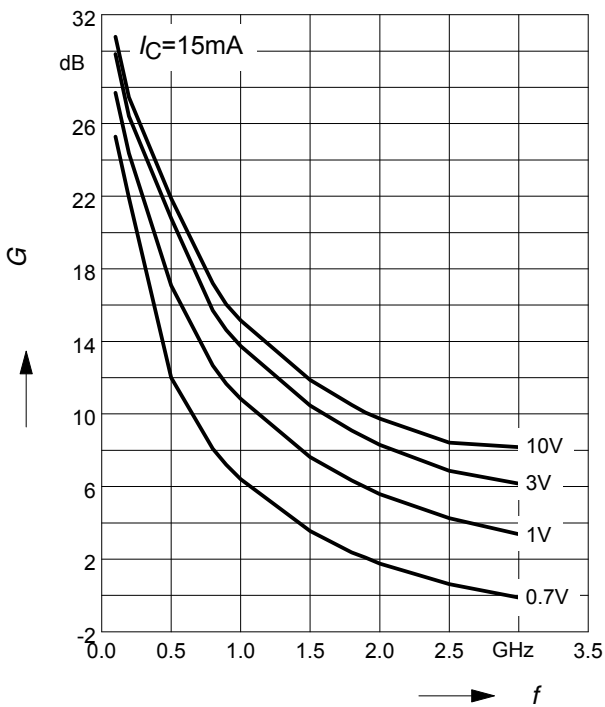

Power Gain $|S_{21}|^2 = f(f)$

$V_{CE} =$ Parameter

