

Si-MMIC-Amplifier in SIEGET 25-Technologie

- Cascadable 50 Ω-gain block
- Unconditionally stable
- Gain $|S_{21}|^2 = 13$ dB at 1.8 GHz
 $IP_{3out} = +9$ dBm at 1.8 GHz
 $(V_D = 3$ V, $I_D = \text{typ. } 6.4$ mA)
- Noise figure $NF = 2.2$ dB at 1.8 GHz
- Reverse isolation > 28 dB and
return loss $IN / OUT > 12$ dB at 1.8 GHz

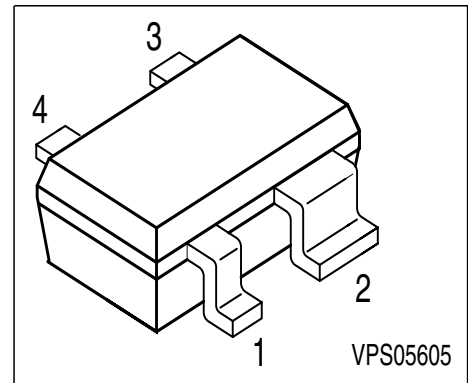

Circuit Diagram

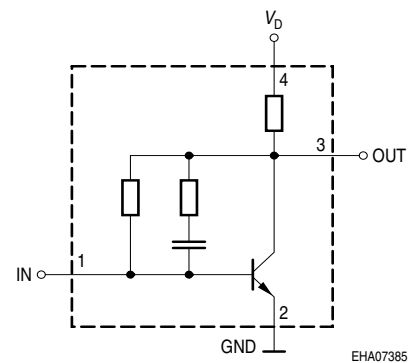

ESD: Electrostatic discharge sensitive device, observe handling precaution!

Type	Marking	Pin Configuration				Package
BGA 420	BLs	1, IN	2, GND	3, OUT	4, VD	SOT-343

Maximum Ratings

Parameter	Symbol	Value	Unit
Device current	I_D	15	mA
Device voltage	V_D	6	V
Total power dissipation, $T_S = 120$ °C ^F)	P_{tot}	90	mW
RF input power	P_{RFIn}	0	dBm
Junction temperature	T_j	150	°C
Ambient temperature	T_A	-65 ... 150	
Storage temperature	T_{stg}	-65 ... 150	

Thermal Resistance

Junction - soldering point	R_{thJS}	≤ 530	K/W
----------------------------	------------	-------	-----

¹ T_S is measured on the emitter (GND) lead at the soldering point to the pcb

Electrical Characteristics at $T_A = 25\text{ }^\circ\text{C}$, unless otherwise specified.

Parameter	Symbol	Values			Unit
		min.	typ.	max.	
AC characteristics					
Device current	I_D	5.4	6.7	8	mA
Insertion power gain	$ S_{21} ^2$				dB
$f = 0.1\text{ GHz}$		17	19	-	
$f = 1\text{ GHz}$		15	17	-	
$f = 1.8\text{ GHz}$		11	13	-	
Reverse isolation	S12	25	28	-	
$f = 1.8\text{ GHz}$					
Noise figure	NF				
$f = 0.1\text{ GHz}$		-	1.9	2.2	
$f = 1\text{ GHz}$		-	2	2.3	
$f = 1.8\text{ GHz}$		-	2.2	2.5	
Intercept point at the output	IP_{3out}	7.5	9	-	dBm
$f = 1\text{ GHz}$					
1dB compression point	P_{-1dB}	-2.5	-1	-	
$f = 1\text{ GHz}$					
Return loss input	RL_{in}	8	11	-	dB
$f = 1.8\text{ GHz}$					
Return loss output	RL_{out}	12	16	-	
$f = 1.8\text{ GHz}$					

Typical biasing configuration

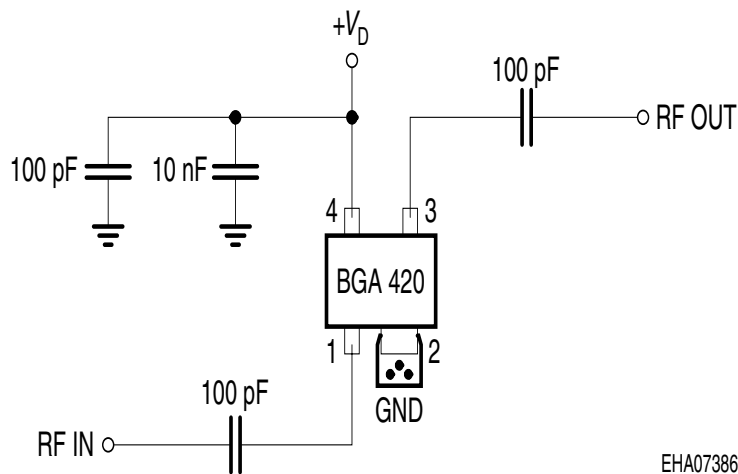

EHA07386

- Note: 1) Large-value capacitors should be connected from pin 4 to ground right at the device to provide a low impedance path.
 2) The use of plated through holes right at pin 2 is essential for pc-board-applications. Thin boards are recommended to minimize the parasitic inductance to ground.

Typical S-Parameters at $T_A = 25\text{ }^\circ\text{C}$

f GHz	S_{11}		S_{21}		S_{12}		S_{22}	
	MAG	ANG	MAG	ANG	MAG	ANG	MAG	ANG
$V_D = 3\text{ V}, Z_0 = 50\text{ }\Omega$								
0.1	0.5686	-8.5	9.314	170.6	0.0268	12.7	0.2808	-8.6
0.5	0.5066	-19.2	8.393	149.4	0.0248	11.7	0.2613	-3.8
0.8	0.4404	-28.7	7.352	135.2	0.0236	25.6	0.2361	-6.7
1	0.3904	-34.6	6.69	126.8	0.024	35.9	0.2144	-9
1.5	0.2841	-50.5	5.244	111.1	0.0314	57.2	0.1398	-15
1.8	0.2343	-60.6	4.567	104	0.0378	63.5	0.0979	-18.2
1.9	0.2136	-64.1	4.355	102	0.0406	66.1	0.0838	-21.5
2	0.2062	-68.4	4.165	99.7	0.0426	67.2	0.0689	-22.2
2.4	0.1688	-89.7	3.417	91.7	0.0549	71.4	0.0224	-48
3	0.1558	-104.9	2.861	85.3	0.0682	73.1	0.0284	-147.5

Spice-model BGA 420

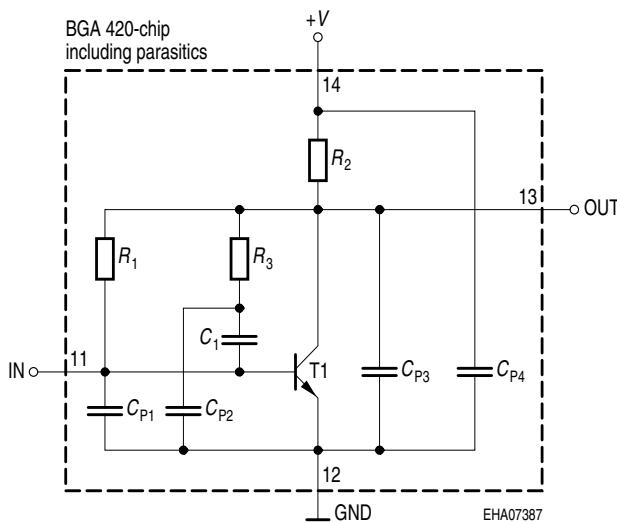

T1	T501
R_1	14.5k Ω
R_2	140 Ω
R_3	2.4k Ω
C_1	2.3pF
C_{P1}	0.2pF
C_{P2}	0.2pF
C_{P3}	0.6pF
C_{P4}	0.1pF

Transistor Chip Data T1 (Berkley-SPICE 2G.6 Syntax) :

IS =	0.21024	fA	BF =	83.23	-	NF =	1.0405	-
VAF =	39.251	V	IKF =	0.16493	A	ISE =	15.761	fA
NE =	1.7763	-	BR =	10.526	-	NR =	0.96647	-
VAR =	34.368	V	IKR =	0.25052	A	ISC =	0.037223	fA
NC =	1.3152	-	RB =	15	Ω	IRB =	0.21215	A
RBM =	1.3491	Ω	RE =	1.9289		RC =	0.12691	Ω
CJE =	3.7265	fF	VJE =	0.70367	V	MJE =	0.37747	-
TF =	4.5899	ps	XTF =	0.3641	-	VTF =	0.19762	V
ITF =	1.3364	mA	PTF =	0	deg	CJC =	96.941	fF
VJC =	0.99532	V	MJC =	0.48652	-	XCJC =	0.08161	-
TR =	1.4935	ns	CJS =	0	fF	VJS =	0.75	V
MJS =	0	-	XTB =	0	-	EG =	1.11	eV
XTI =	3	-	FC =	0.99469	-	TNOM	300	K

C'-E'-Diode Data (Berkley-SPICE 2G.6 Syntax) :

IS =	2	fA	N =	1.02	-	RS =	20	Ω
------	---	----	-----	------	---	------	----	----------

All parameters are ready to use, no scaling is necessary

Package Equivalent Circuit:

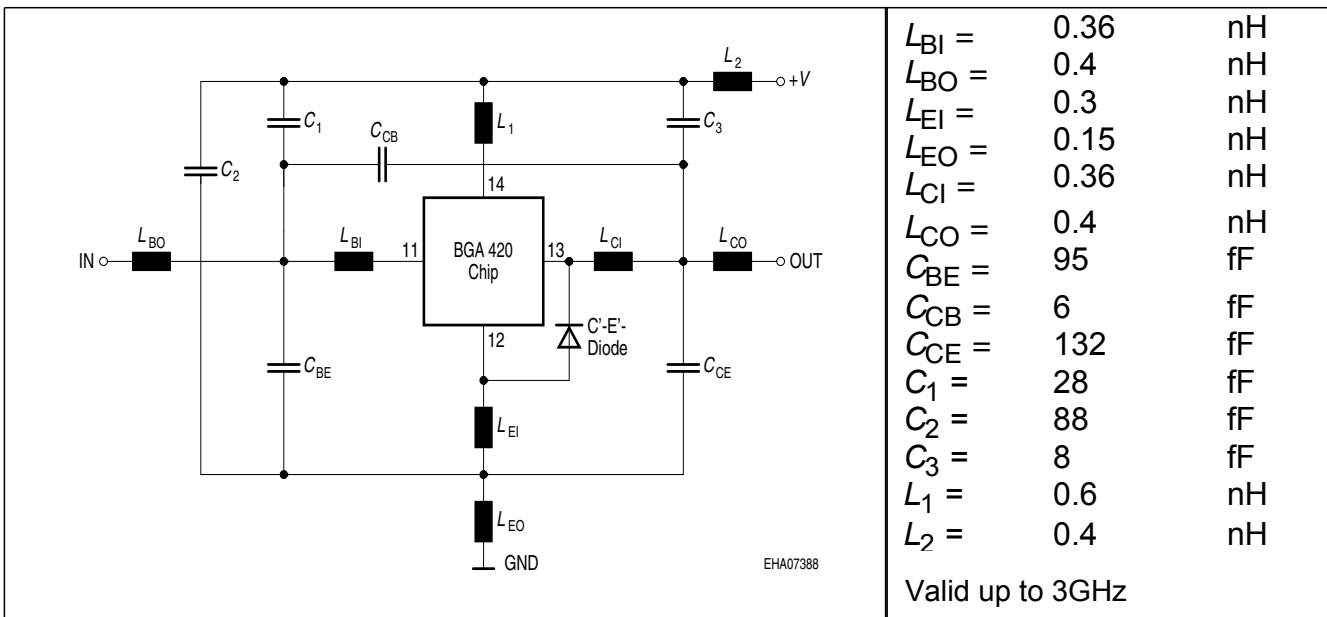

Extracted on behalf of SIEMENS Small Signal Semiconductors by:
Institut für Mobil-und Satellitentechnik (IMST)

© 1996 SIEMENS AG

For examples and ready to use parameters please contact your local Infineon Technologies distributor or salesoffice to obtain a Infineon Technologies CD-ROM or see Internet: <http://www.infineon.com/products/discrete/index.htm>

Insertion power gain $|S_{21}|^2 = f(f)$

$V_D, I_D = \text{parameter}$

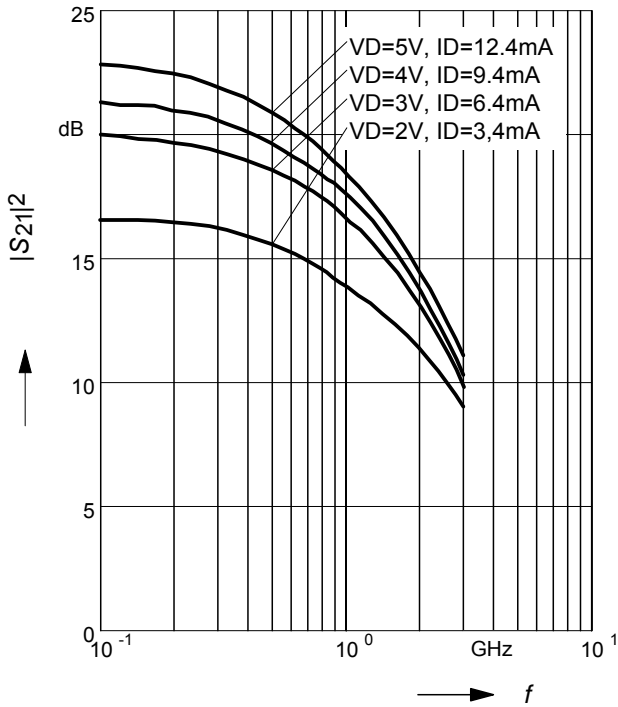

Insertion power gain $|S_{21}|^2 = f(f)$

$V_D = 3V$

$T_A = \text{parameter}$

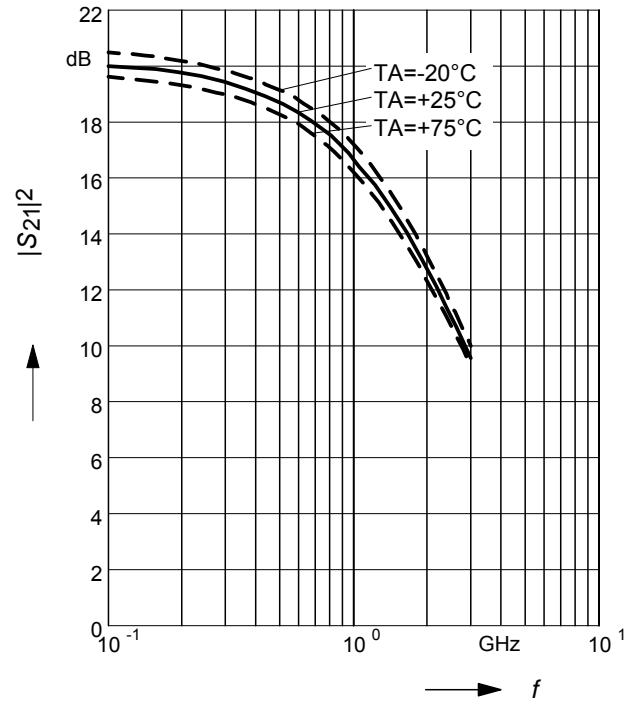

Noise figure $NF = f(f)$

$V_D, I_D = \text{parameter}$

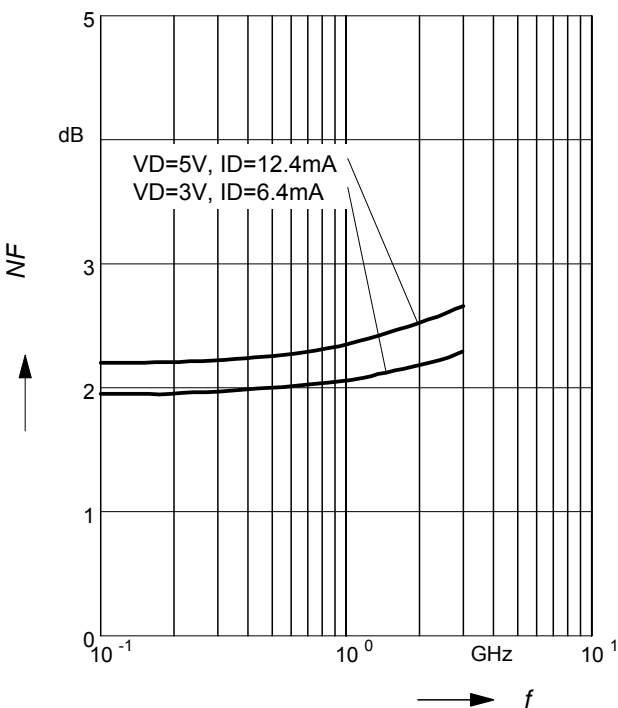

Noise figure $NF = f(f)$

$V_D = 3V$

$T_A = \text{parameter}$

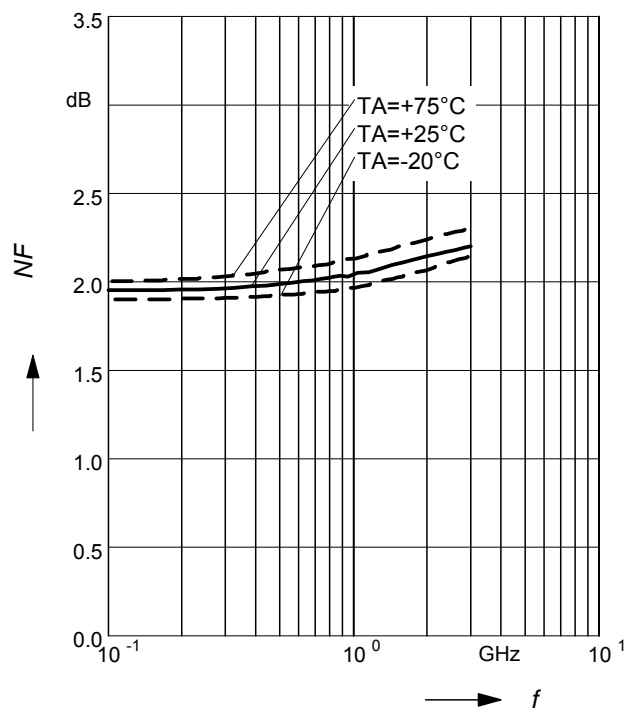

Intercept point at the output

$$IP_{3out} = f(f)$$

$V_D, I_D = \text{parameter}$

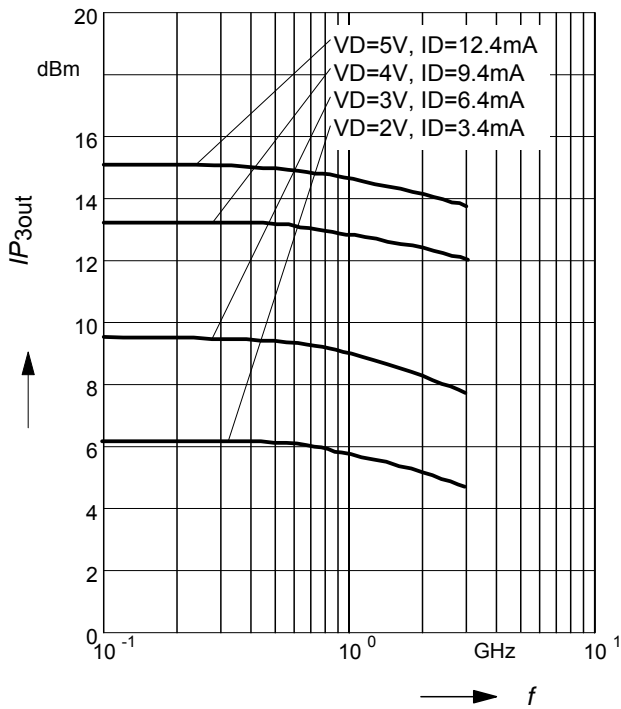

Intercept point at the output

$$IP_{3out} = f(f), V_D = 3V$$

$T_A = \text{parameter}$

