

Version 2.0

Features

- High sensitivity
- High operating temperature range
- High linearity
- Low offset voltage
- Low *TC* of sensitivity and internal resistance
- Plastic-encapsulated miniature package

Typical Applications

- Detection of speed
- Detection of position
- Detection of diaphragm position in pressure pickup cans
- Magnetic field measurement at permanent magnets
- Magnetic field measurement at magnetic yokes for current determination
- Magnetic field measurement in dc motors for contactless commutation

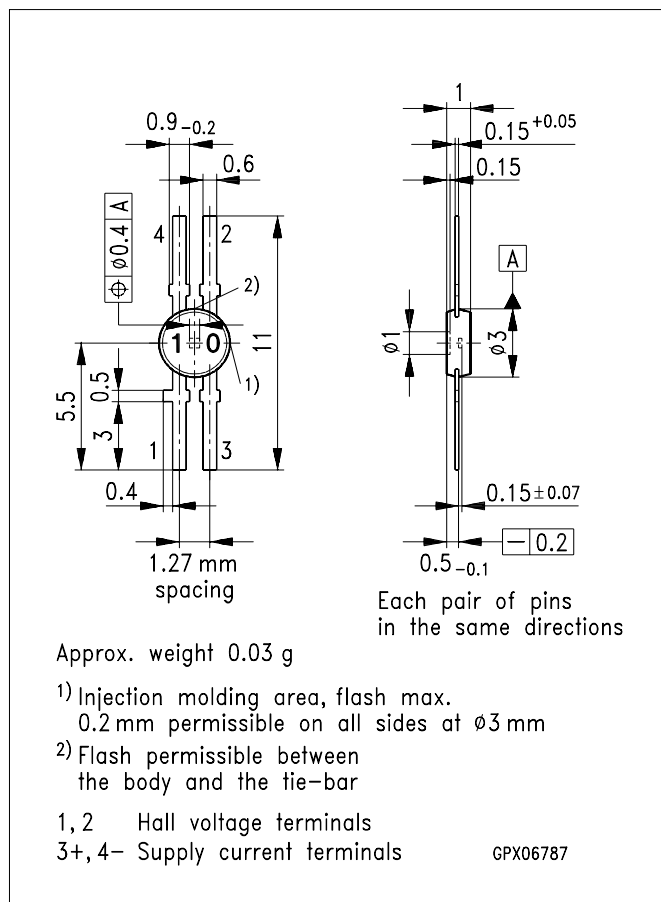

Dimensions in mm

Type	Ordering Code
■ KSY 10	Q62705-K38

■ not for new design

The position sensor KSY 10 is an ion-implanted Hall generator made of mono-crystalline GaAs material. It is enclosed in a tubular plastic package with four tags.

When operating the sensor with a constant supply current, the output Hall voltage is directly proportional to the magnetic field acting upon the sensor. This sensor is outstanding for its high inductive sensitivity and very low temperature coefficient.

The Hall sensor's active area is approx. 0.2 mm × 0.2 mm. It is placed approx. 0.35 mm below the plastic surface of the front side and is concentric towards the adjusting marking on the rear. The chip carrier is non-magnetic.

The position sensor KSY 10 is particularly suitable for sensing the position of magnets and of softmagnetic material, resp., if the sensor itself is mounted on a magnet.

Absolute Maximum Ratings

Parameter	Symbol	Limit Values	Unit
Operating temperature	T_A	- 40 / + 150	°C
Storage temperature	T_{stg}	- 50 / + 160	°C
Supply current	I_1	7	mA
Thermal conductivity ¹⁾	$G_{th A}$	≥ 2.8	mW/K

Electrical Characteristics ($T_A = 25\text{ °C}$)

Nominal supply current	I_{1N}	5	mA
Open-circuit sensitivity	K_{B0}	170...230	V/AT
Open-circuit Hall voltage $I_1 = I_{1N}, B = 0.1\text{ T}$	V_{20}	85...130	mV
Ohmic offset voltage ²⁾ $I_1 = I_{1N}, B = 0\text{ T}$	V_{R0}	≤ ± 25	mV
Linearity of Hall voltage $B = 0...0.5\text{ T}$ $B = 0...1\text{ T}$	F_L	≤ ± 0.2 ≤ ± 0.7	% %
Supply and Hall-side internal resistance $B = 0\text{ T}$	$R_{10, 20}$	900...1200	Ω
Temperature coefficient of the open-circuit Hall voltage $I_1 = I_{1N}, B = 0.2\text{ T}$	TC_{V20}	approx. -0.05	%/K
Temperature coefficient of the internal resistance $B = 0.2\text{ T}$	$TC_{R10, R20}$	0.1 ... 0.18	%/K

¹⁾ Thermal conductivity chip-ambient when soldered, in still air

²⁾ Offset voltage selection upon request

Open-circuit sensitivity K_{B0} versus temperature
referred to K_{B0} at $T_A = 25\text{ °C}$

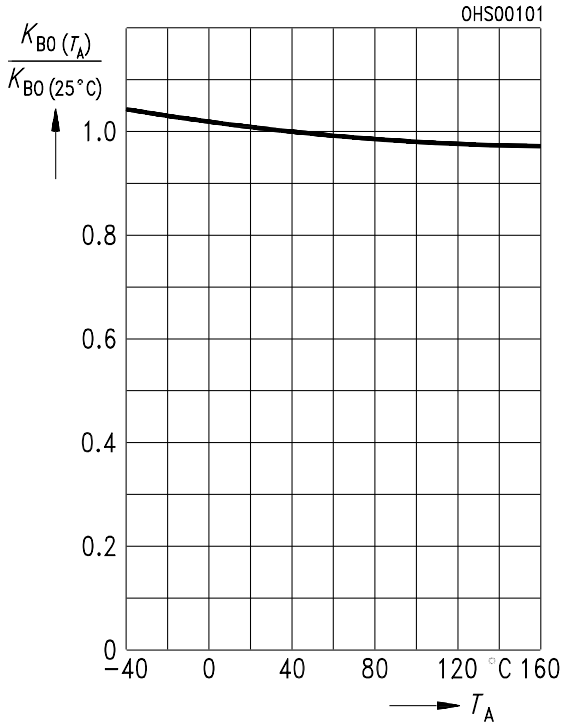

Internal resistance R_{20} versus temperature referred to R_{20} at $T_A = 25\text{ °C}$, Parameter: Flux density B

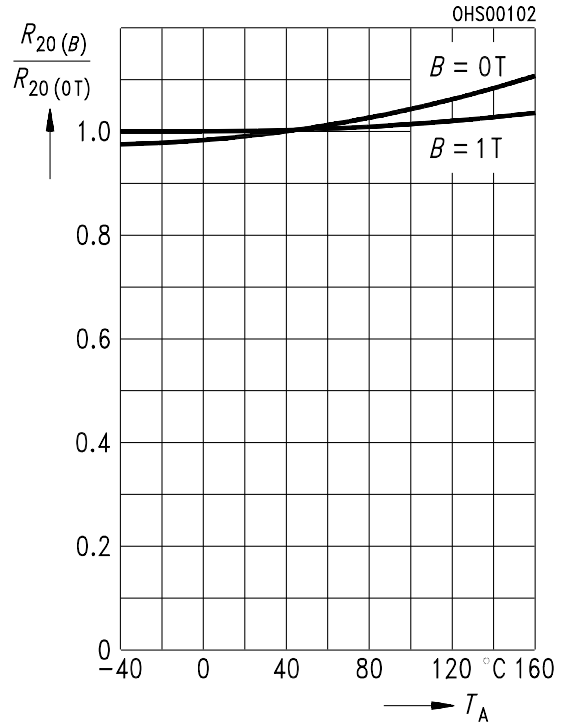

Internal resistance R_{20} versus magnetic field referred to R_{20} at $B = 0\text{ T}$ and $T_A = 25\text{ °C}$

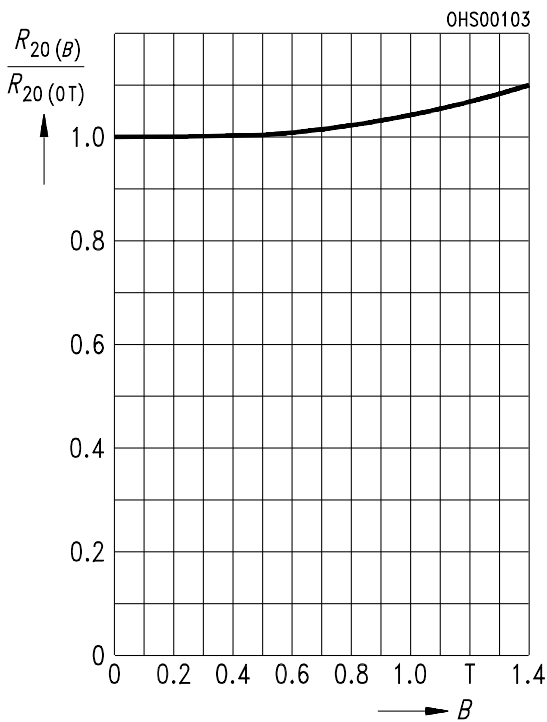

Max. permissible supply current I_1 versus temperature T_A

