

**NPN Silicon Switching Transistor**

- High DC current gain: 0.1mA to 500 mA
- Low collector-emitter saturation voltage
- Complementary type: SMBT 2907A (PNP)

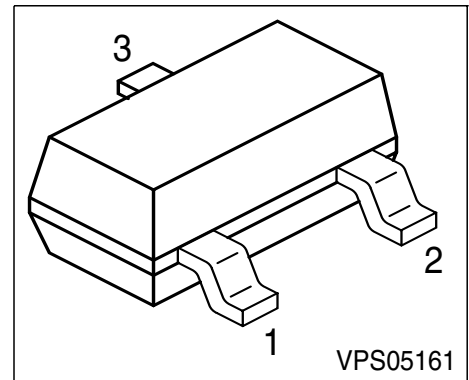

Type	Marking	Pin Configuration			Package
SMBT 2222A	s1B	1=B	2=E	3=C	SOT-23

**Maximum Ratings**

Parameter	Symbol	Value	Unit
Collector-emitter voltage	$V_{CEO}$	40	V
Collector-base voltage	$V_{CBO}$	75	
Emitter-base voltage	$V_{EBO}$	6	
DC collector current	$I_C$	600	mA
Total power dissipation, $T_S = 77\text{ °C}$	$P_{tot}$	330	mW
Junction temperature	$T_j$	150	°C
Storage temperature	$T_{stg}$	-65 ... 150	

**Thermal Resistance**

Junction ambient <sup>1)</sup>	$R_{thJA}$	≤290	K/W
Junction - soldering point	$R_{thJS}$	≤220	

1) Package mounted on pcb 40mm x 40mm x 1.5mm / 6cm<sup>2</sup> Cu

**Electrical Characteristics at  $T_A = 25^\circ\text{C}$ , unless otherwise specified**

Parameter	Symbol	Values			Unit
		min.	typ.	max.	
<b>DC Characteristics</b>					
Collector-emitter breakdown voltage $I_C = 10\text{ mA}, I_B = 0$	$V_{(BR)CEO}$	40	-	-	V
Collector-base breakdown voltage $I_C = 10\text{ }\mu\text{A}, I_B = 0$	$V_{(BR)CBO}$	75	-	-	
Emitter-base breakdown voltage $I_E = 10\text{ }\mu\text{A}, I_C = 0$	$V_{(BR)EBO}$	6	-	-	
Collector cutoff current $V_{CB} = 60\text{ V}, I_E = 0$	$I_{CBO}$	-	-	10	nA
Collector cutoff current $V_{CB} = 60\text{ V}, I_E = 0, T_A = 150\text{ }^\circ\text{C}$	$I_{CBO}$	-	-	10	$\mu\text{A}$
Emitter cutoff current $V_{EB} = 3\text{ V}, I_C = 0$	$I_{EBO}$	-	-	10	nA
DC current gain 1) $I_C = 100\text{ }\mu\text{A}, V_{CE} = 10\text{ V}$ $I_C = 1\text{ mA}, V_{CE} = 10\text{ V}$ $I_C = 10\text{ mA}, V_{CE} = 10\text{ V}$ $I_C = 150\text{ mA}, V_{CE} = 1\text{ V}$ $I_C = 150\text{ mA}, V_{CE} = 10\text{ V}$ $I_C = 500\text{ mA}, V_{CE} = 10\text{ V}$ $I_C = 10\text{ mA}, V_{CE} = 10\text{ V}, T_A = 55^\circ\text{C}$	$h_{FE}$	35 50 75 50 100 40 35	- - - - - - -	- - - - 300 - -	-
Collector-emitter saturation voltage1) $I_C = 150\text{ mA}, I_B = 15\text{ mA}$ $I_C = 500\text{ mA}, I_B = 50\text{ mA}$	$V_{CEsat}$	- -	- -	0.3 1	V
Base-emitter saturation voltage 1) $I_C = 150\text{ mA}, I_B = 15\text{ mA}$ $I_C = 500\text{ mA}, I_B = 50\text{ mA}$	$V_{BEsat}$	0.6 -	- -	1.2 2	

 1) Pulse test:  $t \leq 300\mu\text{s}$ ,  $D = 2\%$

**Electrical Characteristics at  $T_A = 25^\circ\text{C}$ , unless otherwise specified**

Parameter	Symbol	Values			Unit
		min.	typ.	max.	
<b>AC Characteristics</b>					
Transition frequency $I_C = 20\text{ mA}$ , $V_{CE} = 20\text{ V}$ , $f = 100\text{ MHz}$	$f_T$	300	-	-	MHz
Collector-base capacitance $V_{CB} = 10\text{ V}$ , $f = 1\text{ MHz}$	$C_{cb}$	-	-	8	pF
Emitter-base capacitance $V_{EB} = 0.5\text{ V}$ , $f = 1\text{ MHz}$	$C_{eb}$	-	-	25	
Noise figure $I_C = 100\text{ }\mu\text{A}$ , $V_{CE} = 10\text{ V}$ , $R_S = 1\text{ k}\Omega$ , $f = 1\text{ kHz}$ , $\Delta f = 200\text{ Hz}$	$F$	-	-	4	dB
Short-circuit input impedance $I_C = 1\text{ mA}$ , $V_{CE} = 10\text{ V}$ , $f = 1\text{ kHz}$ $I_C = 10\text{ mA}$ , $V_{CE} = 10\text{ V}$ , $f = 1\text{ kHz}$	$h_{11e}$	2 0.25	- -	8 1.25	k $\Omega$
Open-circuit reverse voltage transf.ratio $I_C = 1\text{ mA}$ , $V_{CE} = 10\text{ V}$ , $f = 1\text{ kHz}$ $I_C = 10\text{ mA}$ , $V_{CE} = 10\text{ V}$ , $f = 1\text{ kHz}$	$h_{12e}$	- -	- -	8 4	$10^{-4}$
Short-circuit forward current transf.ratio $I_C = 1\text{ mA}$ , $V_{CE} = 10\text{ V}$ , $f = 1\text{ kHz}$ $I_C = 10\text{ mA}$ , $V_{CE} = 10\text{ V}$ , $f = 1\text{ kHz}$	$h_{21e}$	50 75	- -	300 375	-
Open-circuit output admittance $I_C = 1\text{ mA}$ , $V_{CE} = 10\text{ V}$ , $f = 1\text{ kHz}$ $I_C = 10\text{ mA}$ , $V_{CE} = 10\text{ V}$ , $f = 1\text{ kHz}$	$h_{22e}$	5 25	- -	35 200	$\mu\text{S}$
Delay time $V_{CC} = 30\text{ V}$ , $I_C = 150\text{ mA}$ , $I_{B1} = 15\text{ mA}$ , $V_{BE(\text{off})} = 0.5\text{ V}$	$t_d$	-	-	10	ns
Rise time $V_{CC} = 30\text{ V}$ , $I_C = 150\text{ mA}$ , $I_{B1} = 15\text{ mA}$ , $V_{BE(\text{off})} = 0.5\text{ V}$	$t_r$	-	-	25	
Storage time $V_{CC} = 30\text{ V}$ , $I_C = 150\text{ mA}$ , $I_{B1} = I_{B2} = 15\text{ mA}$	$t_{stg}$	-	-	225	
Fall time $V_{CC} = 30\text{ V}$ , $I_C = 150\text{ mA}$ , $I_{B1} = I_{B2} = 15\text{ mA}$	$t_f$	-	-	60	

### Test circuits

#### Delay and rise time

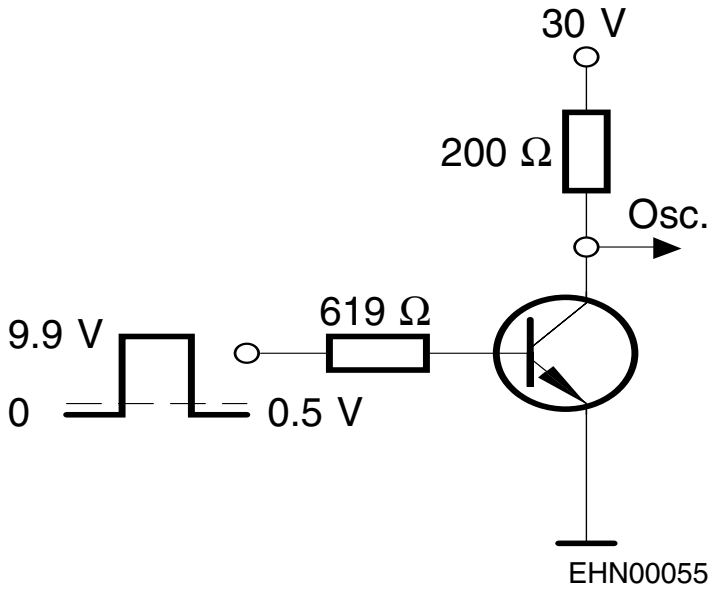

#### Storage and fall time

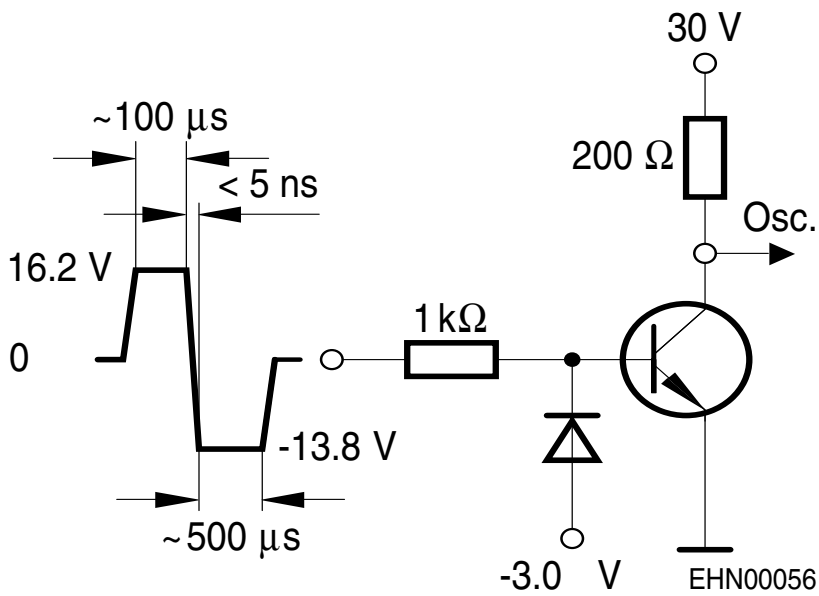

Oscilloscope:  $R > 100\Omega$ ,  $C < 12\text{pF}$ ,  $t_r < 5\text{ns}$

**Total power dissipation  $P_{tot} = f(T_A^*; T_S)$**

\* Package mounted on epoxy

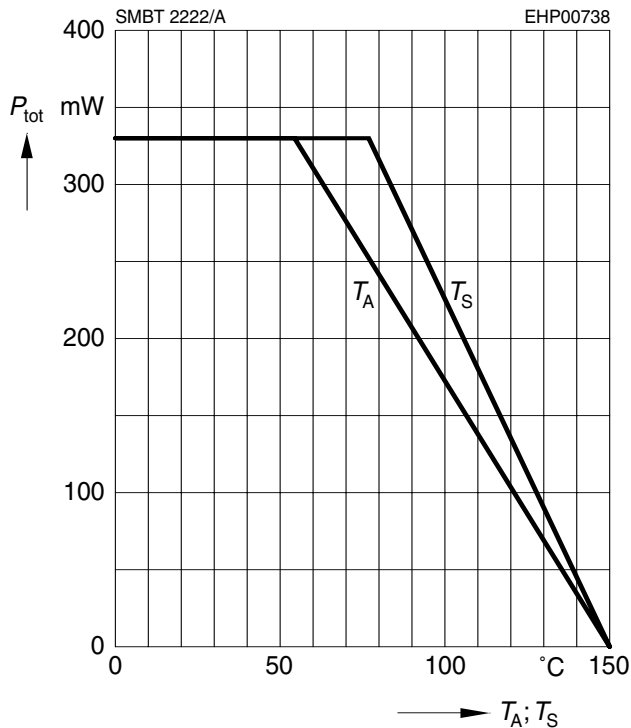

**Collector-base capacitance  $C_{CB} = f(V_{CB})$**

$f = 1\text{MHz}$

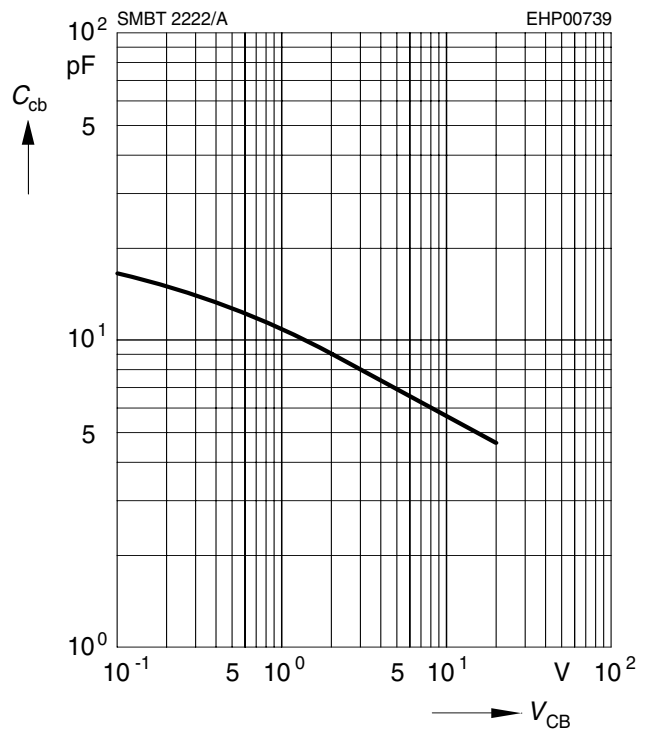

**Permissible pulse load**

$P_{totmax} / P_{totDC} = f(t_p)$

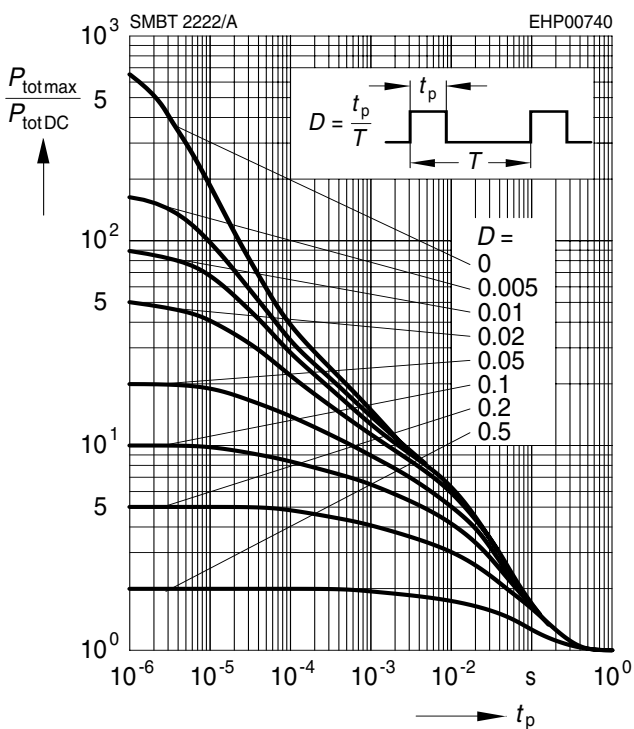

**Transition frequency  $f_T = f(I_C)$**

$V_{CE} = 20\text{V}$

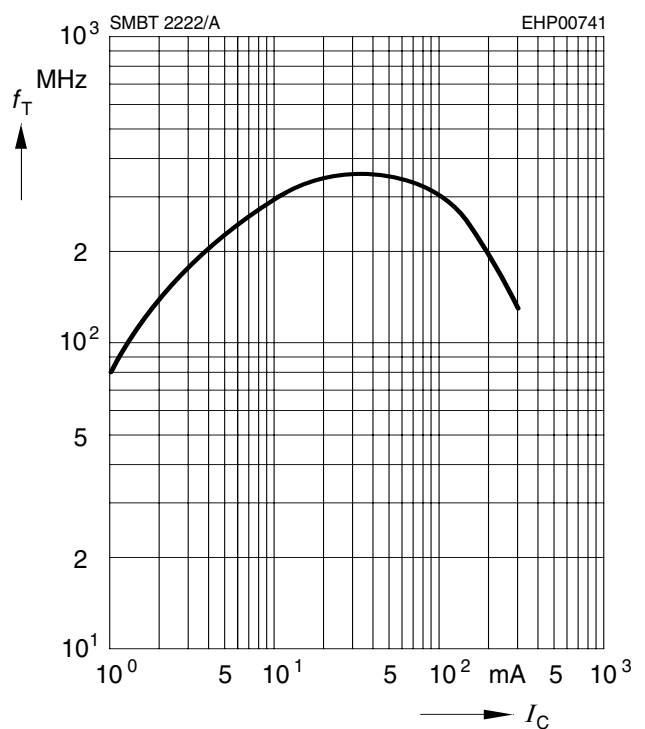

**Saturation voltage**  $I_C = f(V_{BEsat}, V_{CEsat})$   
 $h_{FE} = 10$

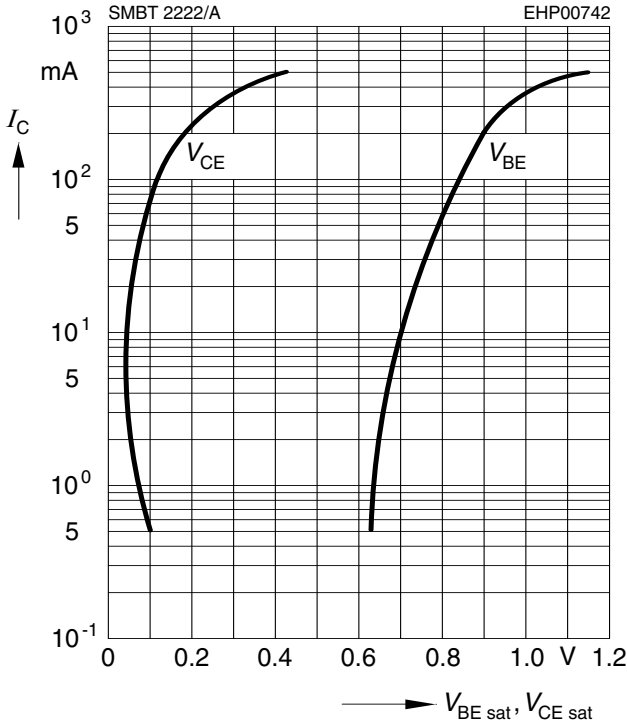

**DC current gain**  $h_{FE} = f(I_C)$   
 $V_{CE} = 10V$

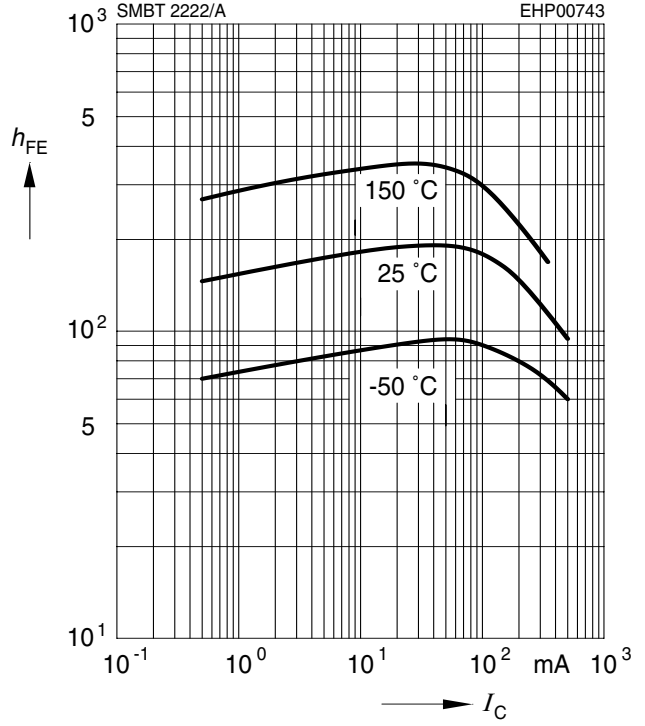

**Delay time**  $t_d = f(I_C)$   
**Rise time**  $t_r = f(I_C)$

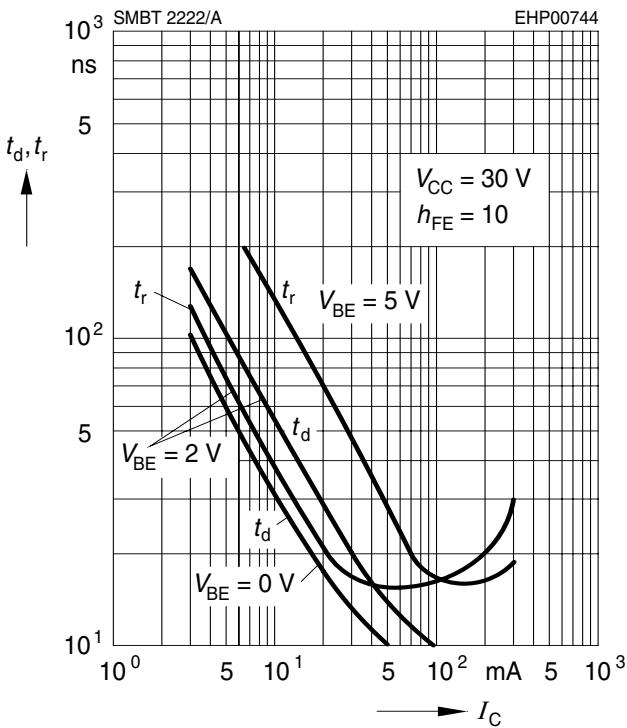

**Storage time**  $t_{stg} = f(I_C)$   
**Fall time**  $t_f = f(I_C)$

