



74LVX74

LOW VOLTAGE CMOS DUAL D-TYPE FLIP FLOP WITH PRESET AND CLEAR (5V TOLERANT INPUTS)

- HIGH SPEED :
 $f_{MAX} = 145\text{MHz}$ (TYP.) at $V_{CC} = 3.3\text{V}$
- 5V TOLERANT INPUTS
- INPUT VOLTAGE LEVEL :
 $V_{IL} = 0.8\text{V}$, $V_{IH} = 2\text{V}$ AT $V_{CC} = 3\text{V}$
- LOW POWER DISSIPATION:
 $I_{CC} = 2\ \mu\text{A}$ (MAX.) at $T_A = 25^\circ\text{C}$
- LOW NOISE:
 $V_{OLP} = 0.3\text{V}$ (TYP.) at $V_{CC} = 3.3\text{V}$
- SYMMETRICAL OUTPUT IMPEDANCE:
 $|I_{OH}| = I_{OL} = 4\text{mA}$ (MIN)
- BALANCED PROPAGATION DELAYS:
 $t_{PLH} \cong t_{PHL}$
- OPERATING VOLTAGE RANGE:
 $V_{CC}(\text{OPR}) = 2\text{V}$ to 3.6V (1.2V Data Retention)
- PIN AND FUNCTION COMPATIBLE WITH 74 SERIES 74
- IMPROVED LATCH-UP IMMUNITY
- POWER DOWN PROTECTION ON INPUTS

DESCRIPTION

The 74LVX74 is a low voltage CMOS DUAL D-TYPE FLIP-FLOP WITH PRESET AND CLEAR NON INVERTING fabricated with sub-micron silicon gate and double-layer metal wiring C²MOS technology. It is ideal for low power, battery operated and low noise 3.3V applications.

PIN CONNECTION AND IEC LOGIC SYMBOLS

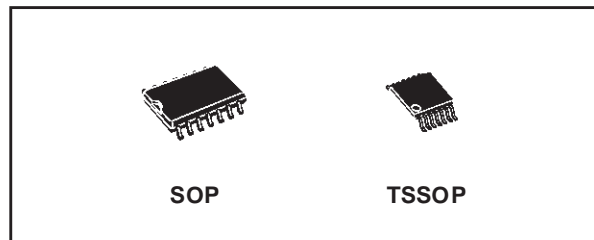
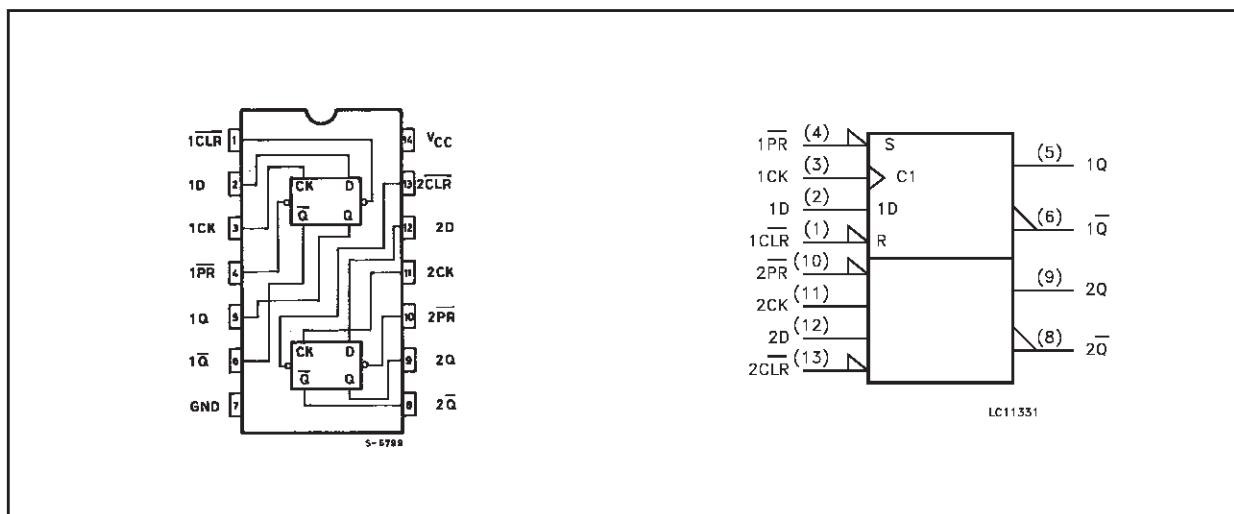

ORDER CODES

PACKAGE	TUBE	T & R
SOP	74LVX74M	74LVX74MTR
TSSOP		74LVX74TTR

A signal on the D INPUT is transferred to the Q OUTPUT during the positive going transition of the clock pulse. CLR and PR are independent of the clock and accomplished by a low setting on the appropriate input.

Power down protection is provided on all inputs and 0 to 7V can be accepted on inputs with no regard to the supply voltage.

This device can be used to interface 5V to 3V system. It combines high speed performance with the true CMOS low power consumption. All inputs and outputs are equipped with protection circuits against static discharge, giving them 2KV ESD immunity and transient excess voltage.

INPUT EQUIVALENT CIRCUIT

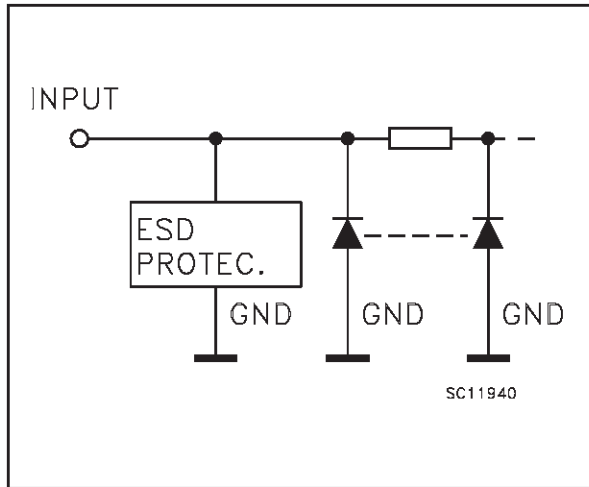

PIN DESCRIPTION

PIN No	SYMBOL	NAME AND FUNCTION
1, 13	$1\overline{\text{CLR}}, 2\overline{\text{CLR}}$	Asynchronous Reset - Direct Input
2, 12	1D, 2D	Data Inputs
3, 11	1CK, 2CK	Clock Input (LOW to HIGH, Edge Triggered)
4, 10	1PR, 2PR	Asynchronous Set - Direct Input
5, 9	1Q, 2Q	True Flip-Flop Outputs
6, 8	1 $\overline{\text{Q}}$, 2 $\overline{\text{Q}}$	Complement Flip-Flop Outputs
7	GND	Ground (0V)
14	V _{CC}	Positive Supply Voltage

TRUTH TABLE

INPUTS				OUTPUTS		FUNCTION
$\overline{\text{CLR}}$	$\overline{\text{PR}}$	D	CK	Q	$\overline{\text{Q}}$	
L	H	X	X	L	H	CLEAR
H	L	X	X	H	L	PRESET
L	L	X	X	H	H	
H	H	L		L	H	
H	H	H		H	L	
H	H	X		Q _n	$\overline{\text{Q}}_n$	NO CHANGE

X : Don't Care

LOGIC DIAGRAM

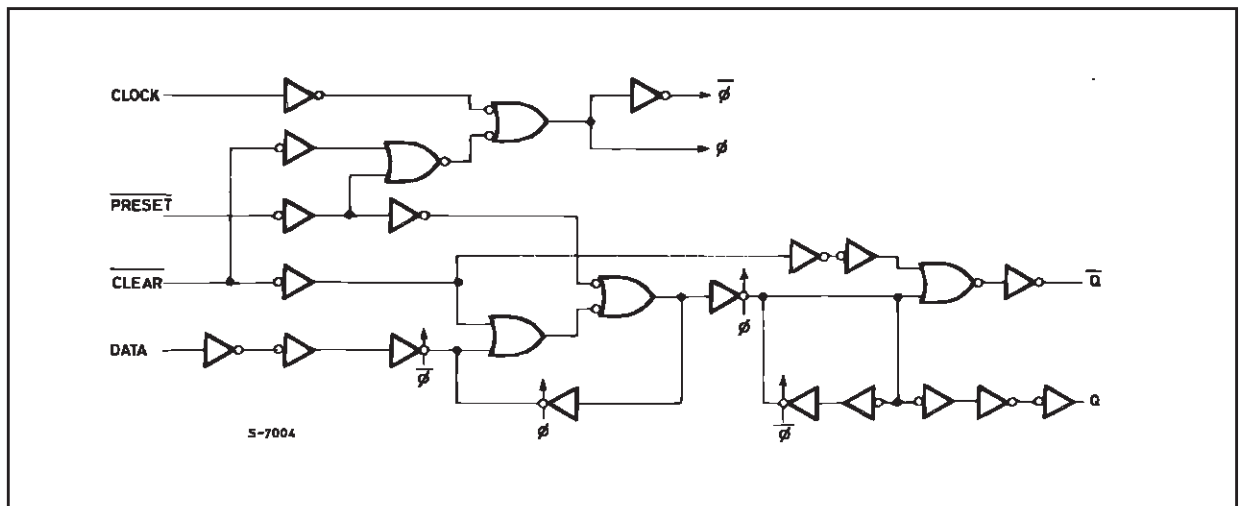

This logic diagram has not been used to estimate propagation delays

ABSOLUTE MAXIMUM RATINGS

Symbol	Parameter	Value	Unit
V_{CC}	Supply Voltage	-0.5 to +7.0	V
V_I	DC Input Voltage	-0.5 to +7.0	V
V_O	DC Output Voltage	-0.5 to $V_{CC} + 0.5$	V
I_{IK}	DC Input Diode Current	- 20	mA
I_{OK}	DC Output Diode Current	± 20	mA
I_O	DC Output Current	± 25	mA
I_{CC} or I_{GND}	DC V_{CC} or Ground Current	± 50	mA
T_{stg}	Storage Temperature	-65 to +150	$^{\circ}\text{C}$
T_L	Lead Temperature (10 sec)	300	$^{\circ}\text{C}$

Absolute Maximum Ratings are those values beyond which damage to the device may occur. Functional operation under these conditions is not implied.

RECOMMENDED OPERATING CONDITIONS

Symbol	Parameter	Value	Unit
V_{CC}	Supply Voltage (note 1)	2 to 3.6	V
V_I	Input Voltage	0 to 5.5	V
V_O	Output Voltage	0 to V_{CC}	V
T_{op}	Operating Temperature	-55 to 125	$^{\circ}\text{C}$
dt/dv	Input Rise and Fall Time (note 2) ($V_{CC} = 3.3\text{V}$)	0 to 100	ns/V

1) Truth Table guaranteed: 1.2V to 3.6V

2) V_{IN} from 0.8V to 2.0V

DC SPECIFICATIONS

Symbol	Parameter	Test Condition		Value						Unit		
				$T_A = 25^{\circ}\text{C}$			-40 to 85 $^{\circ}\text{C}$		-55 to 125 $^{\circ}\text{C}$			
				Min.	Typ.	Max.	Min.	Max.	Min.		Max.	
V_{IH}	High Level Input Voltage	2.0			1.5			1.5		1.5		V
		3.0			2.0			2.0		2.0		
		3.6			2.4			2.4		2.4		
V_{IL}	Low Level Input Voltage	2.0					0.5		0.5		0.5	V
		3.0					0.8		0.8		0.8	
		3.6					0.8		0.8		0.8	
V_{OH}	High Level Output Voltage	2.0	$I_O = -50 \mu\text{A}$	1.9	2.0		1.9		1.9		1.9	V
		3.0	$I_O = -50 \mu\text{A}$	2.9	3.0		2.9		2.9		2.9	
		3.0	$I_O = -4 \text{mA}$	2.58			2.48		2.4		2.4	
V_{OL}	Low Level Output Voltage	2.0	$I_O = 50 \mu\text{A}$		0.0	0.1		0.1		0.1		V
		3.0	$I_O = 50 \mu\text{A}$		0.0	0.1		0.1		0.1		
		3.0	$I_O = 4 \text{mA}$			0.36		0.44		0.55		
I_I	Input Leakage Current	3.6	$V_I = 5\text{V}$ or GND			± 0.1		± 1		± 1	μA	
I_{CC}	Quiescent Supply Current	3.6	$V_I = V_{CC}$ or GND			2		20		20	μA	

DYNAMIC SWITCHING CHARACTERISTICS

Symbol	Parameter	Test Condition		Value						Unit	
		V _{CC} (V)		T _A = 25°C			-40 to 85°C		-55 to 125°C		
				Min.	Typ.	Max.	Min.	Max.	Min.		Max.
V _{OLP}	Dynamic Low Voltage Quiet Output (note 1, 2)	3.3	C _L = 50 pF		0.3	0.5					V
V _{OLV}				-0.5	-0.3						
V _{IHD}	Dynamic High Voltage Input (note 1, 3)	3.3		2							
V _{ILD}	Dynamic Low Voltage Input (note 1, 3)	3.3				0.8					

1) Worst case package.

2) Max number of outputs defined as (n). Data inputs are driven 0V to 3.3V, (n-1) outputs switching and one output at GND.

3) Max number of data inputs (n) switching. (n-1) switching 0V to 3.3V. Inputs under test switching: 3.3V to threshold (V_{ILD}), 0V to threshold (V_{IHD}), f=1MHz.

AC ELECTRICAL CHARACTERISTICS (Input $t_r = t_f = 3\text{ns}$)

Symbol	Parameter	Test Condition		Value						Unit	
		V_{CC} (V)	C_L (pF)	$T_A = 25^\circ\text{C}$			-40 to 85°C		-55 to 125°C		
				Min.	Typ.	Max.	Min.	Max.	Min.		Max.
t_{PLH} t_{PHL}	Propagation Delay Time \overline{CK} to Q or \overline{Q}	2.7	15		7.3	15.0	1.0	18.5	1.0	18.5	ns
		2.7	50		9.8	18.5	1.0	22.0	1.0	22.0	
		3.3 ^(*)	15		5.7	9.7	1.0	11.5	1.0	11.5	
		3.3 ^(*)	50		8.2	13.2	1.0	15.0	1.0	15.0	
t_{PLH} t_{PHL}	Propagation Delay Time \overline{PR} or \overline{CLR} to Q or \overline{Q}	2.7	15		8.4	15.6	1.0	18.5	1.0	18.5	ns
		2.7	50		10.9	19.1	1.0	22.0	1.0	22.0	
		3.3 ^(*)	15		6.6	10.1	1.0	12.0	1.0	12.0	
		3.3 ^(*)	50		9.1	13.6	1.0	15.5	1.0	15.5	
t_w	Minimum Pulse Width HIGH or LOW, CK	2.7	50			8.5		10.0		10.0	ns
		3.3 ^(*)	50			6.0		7.0		7.0	
$t_{w(L)}$	Minimum Pulse Width <u>LOW</u> \overline{PR} or \overline{CLR}	2.7	50			8.5		10.0		10.0	ns
		3.3 ^(*)	50			6.0		7.0		7.0	
t_s	Minimum Setup Time D to CK HIGH or LOW	2.7	50			8.0		9.5		9.5	ns
		3.3 ^(*)	50			5.5		6.5		6.5	
t_h	Minimum Hold Time D to CK HIGH or LOW	2.7	50			0.5		0.5		0.5	ns
		3.3 ^(*)	50			0.5		0.5		0.5	
t_{REM}	Minimum Removal Time \overline{PR} or \overline{CLR} to CK	2.7	50			6.5		7.5		7.5	ns
		3.3 ^(*)	50			5.0		5.0		5.0	
f_{MAX}	Maximum Clock Frequency	2.7	15		55	135		50		50	MHz
		2.7	50		45	60		40		40	
		3.3 ^(*)	15		95	145		80		80	
		3.3 ^(*)	50		60	85		50		50	
t_{OSLH} t_{OSHL}	Output To Output Skew Time (note 1, 2)	2.7	50			0.5	1.0		1.5	1.5	ns
		3.3 ^(*)	50			0.5	1.0		1.5	1.5	

1) Skew is defined as the absolute value of the difference between the actual propagation delay for any two outputs of the same device switching in the same direction, either HIGH or LOW

2) Parameter guaranteed by design

(*) Voltage range is $3.3\text{V} \pm 0.3\text{V}$

CAPACITIVE CHARACTERISTICS

Symbol	Parameter	Test Condition		Value						Unit	
		V_{CC} (V)		$T_A = 25^\circ\text{C}$			-40 to 85°C		-55 to 125°C		
				Min.	Typ.	Max.	Min.	Max.	Min.		Max.
C_{IN}	Input Capacitance	3.3			4	10		10		10	pF
C_{PD}	Power Dissipation Capacitance (note 1)	3.3	$f_{IN} = 10\text{ MHz}$		25						pF

1) C_{PD} is defined as the value of the IC's internal equivalent capacitance which is calculated from the operating current consumption without load. (Refer to Test Circuit). Average operating current can be obtained by the following equation. $I_{CC(OPR)} = C_{PD} \times V_{CC} \times f_{IN} + I_{CC}/2$ (per circuit)

TEST CIRCUIT

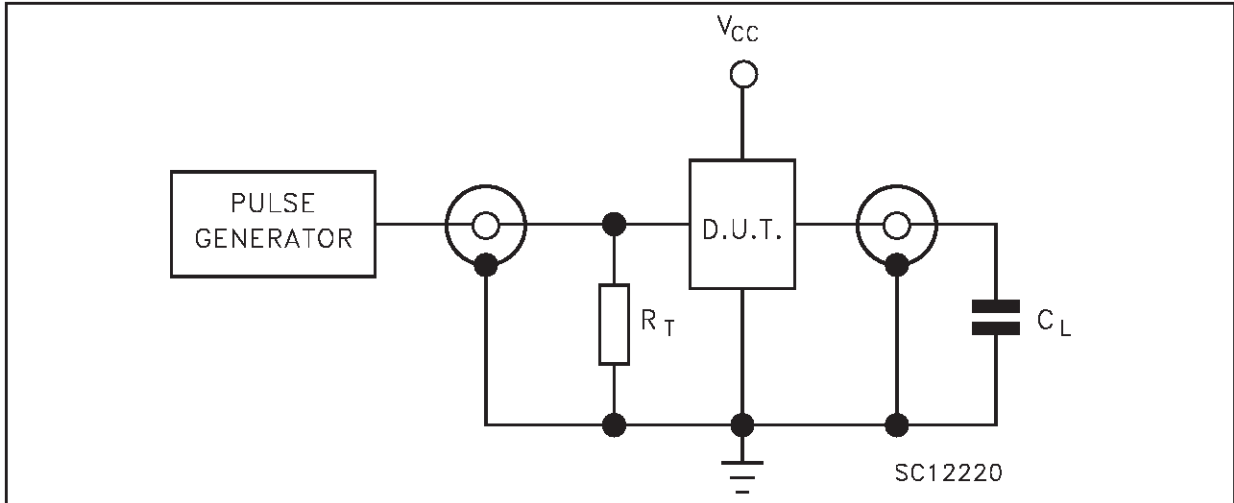

$C_L = 15/50\text{pF}$ or equivalent (includes jig and probe capacitance)
 $R_T = Z_{OUT}$ of pulse generator (typically 50Ω)

WAVEFORM 1 : PROPAGATION DELAYS, SETUP AND HOLD TIMES ($f=1\text{MHz}$; 50% duty cycle)

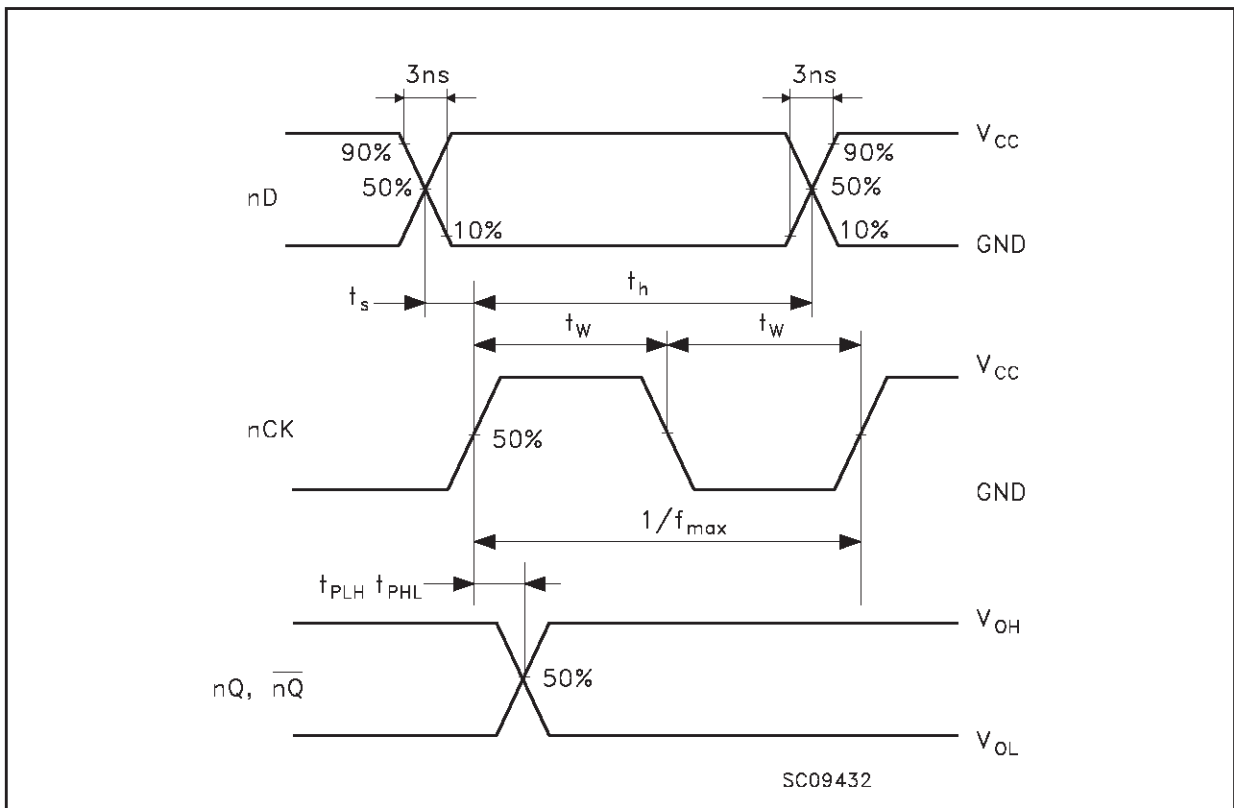

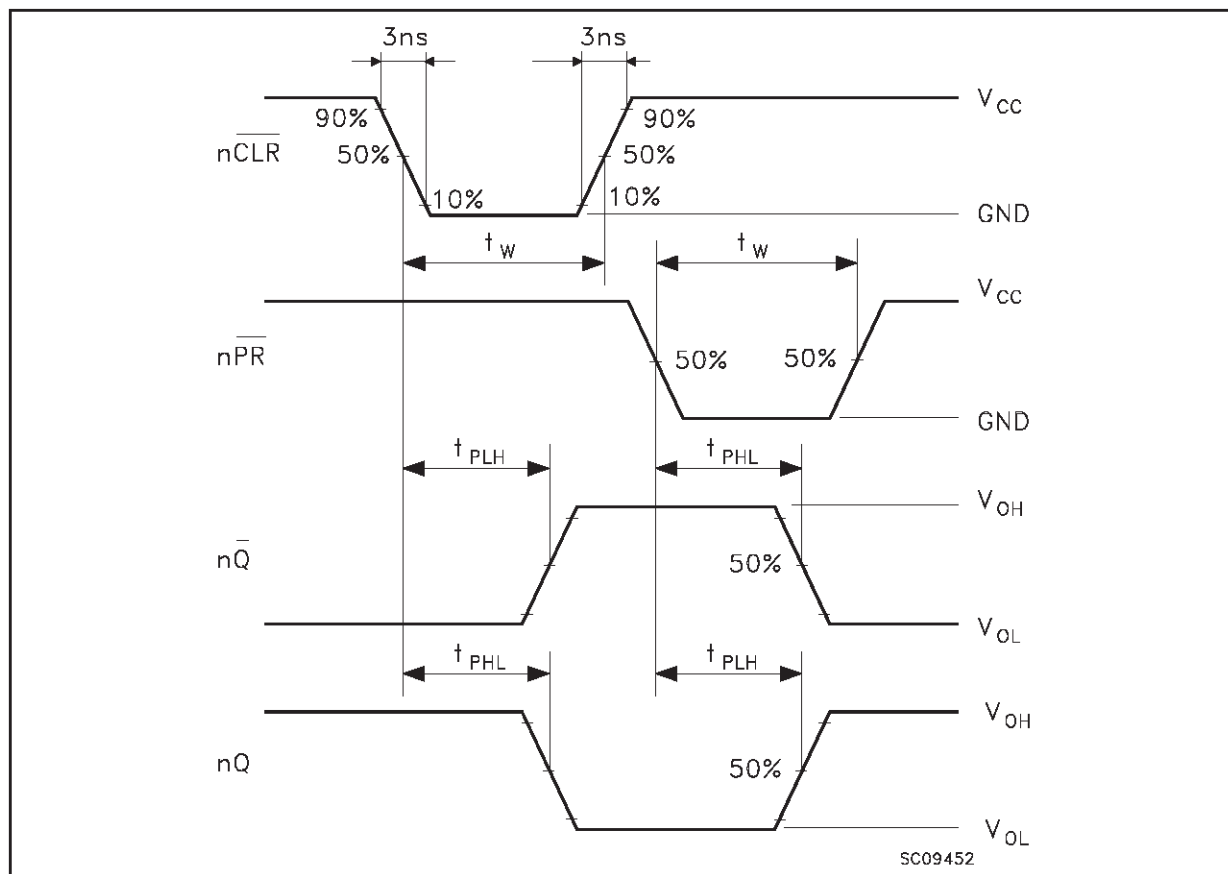
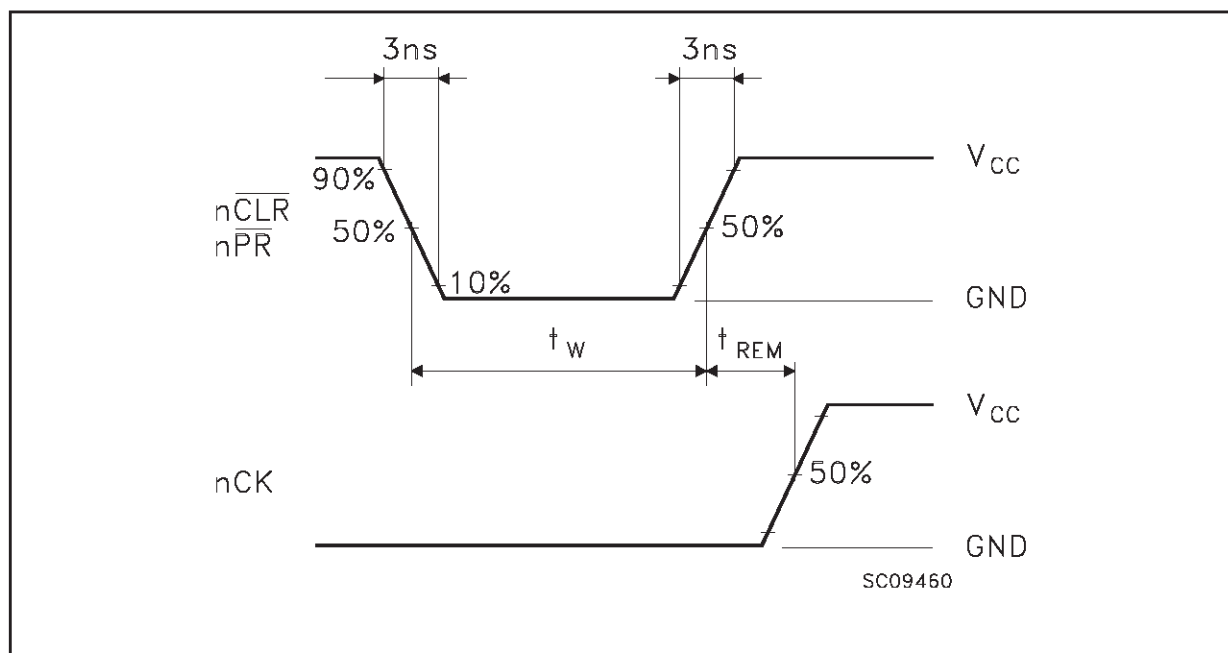
WAVEFORM 2 : PROPAGATION DELAYS, MINIMUM PULSE WIDTH (f=1MHz; 50% duty cycle)**WAVEFORM 3 : RECOVERY TIME** (f=1MHz; 50% duty cycle)

WAVEFORM 4 : MINIMUM PULSE WIDTH

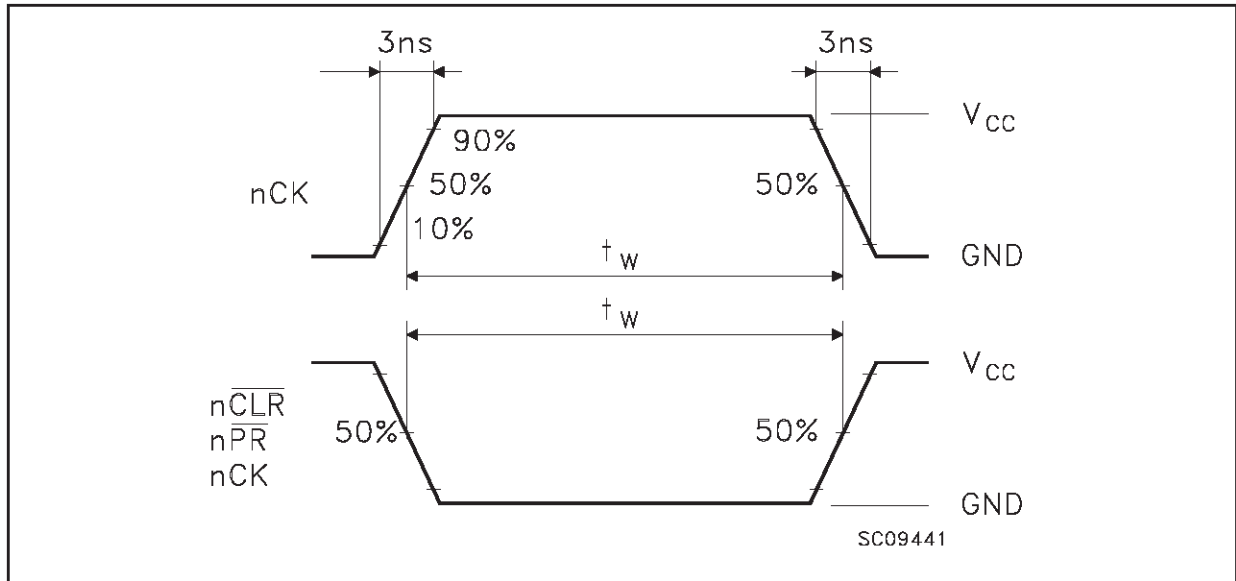

SO-14 MECHANICAL DATA

DIM.	mm.			inch		
	MIN.	TYP.	MAX.	MIN.	TYP.	MAX.
A			1.75			0.068
a1	0.1		0.2	0.003		0.007
a2			1.65			0.064
b	0.35		0.46	0.013		0.018
b1	0.19		0.25	0.007		0.010
C		0.5			0.019	
c1	45° (typ.)					
D	8.55		8.75	0.336		0.344
E	5.8		6.2	0.228		0.244
e		1.27			0.050	
e3		7.62			0.300	
F	3.8		4.0	0.149		0.157
G	4.6		5.3	0.181		0.208
L	0.5		1.27	0.019		0.050
M			0.68			0.026
S	8° (max.)					

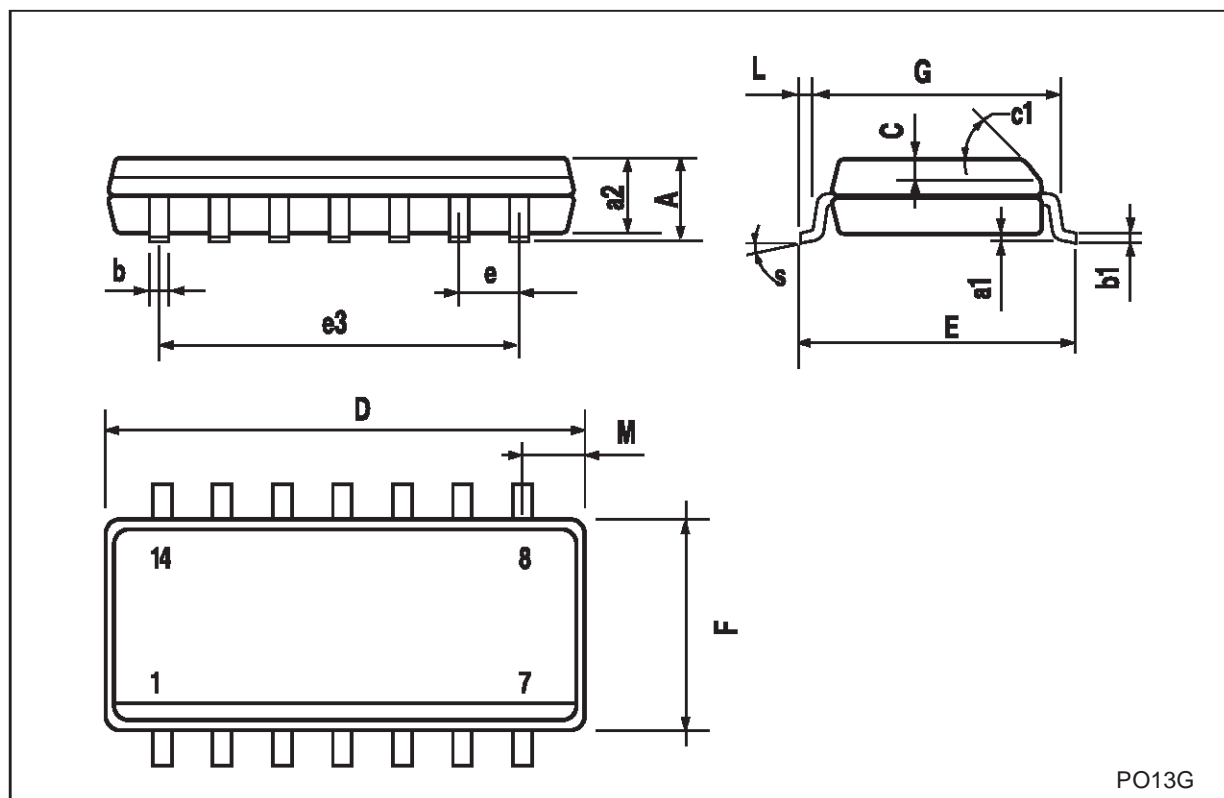

TSSOP14 MECHANICAL DATA

DIM.	mm.			inch		
	MIN.	TYP	MAX.	MIN.	TYP.	MAX.
A			1.2			0.047
A1	0.05		0.15	0.002	0.004	0.006
A2	0.8	1	1.05	0.031	0.039	0.041
b	0.19		0.30	0.007		0.012
c	0.09		0.20	0.004		0.0089
D	4.9	5	5.1	0.193	0.197	0.201
E	6.2	6.4	6.6	0.244	0.252	0.260
E1	4.3	4.4	4.48	0.169	0.173	0.176
e		0.65 BSC			0.0256 BSC	
K	0°		8°	0°		8°
L	0.45	0.60	0.75	0.018	0.024	0.030

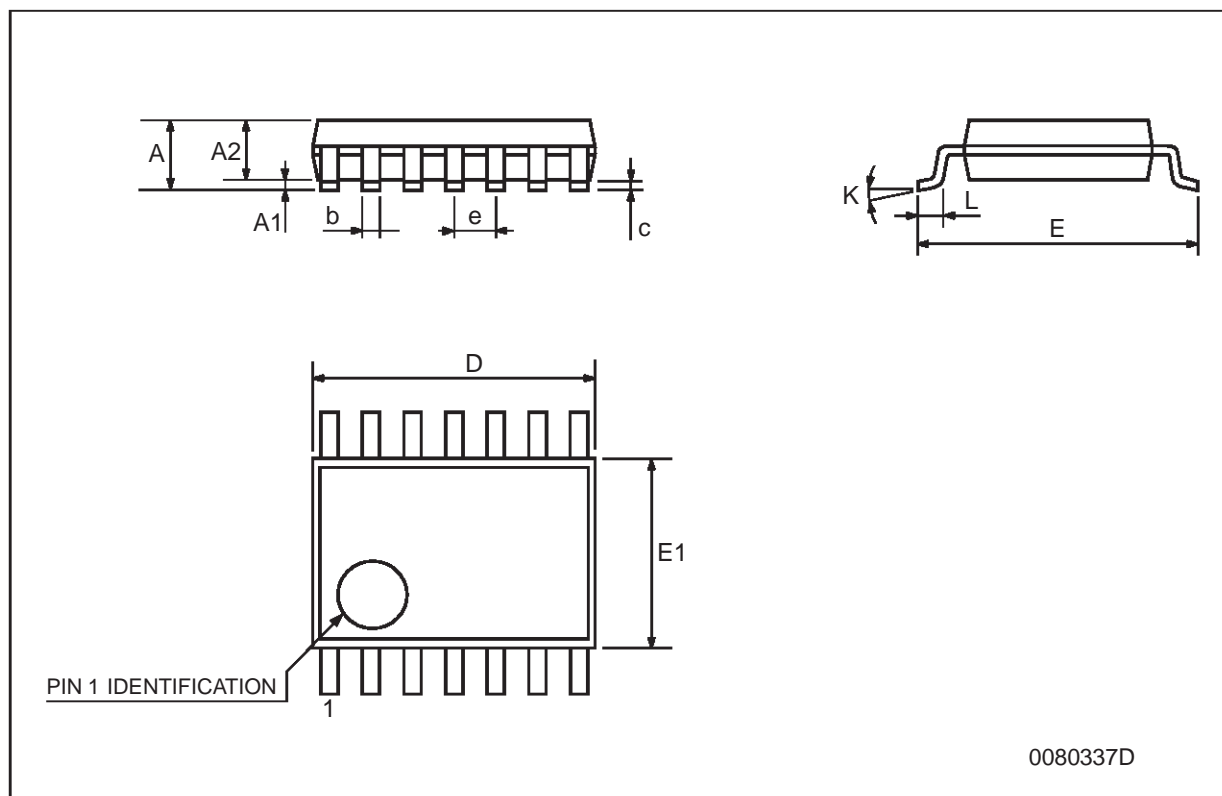

Information furnished is believed to be accurate and reliable. However, STMicroelectronics assumes no responsibility for the consequences of use of such information nor for any infringement of patents or other rights of third parties which may result from its use. No license is granted by implication or otherwise under any patent or patent rights of STMicroelectronics. Specifications mentioned in this publication are subject to change without notice. This publication supersedes and replaces all information previously supplied. STMicroelectronics products are not authorized for use as critical components in life support devices or systems without express written approval of STMicroelectronics.

© The ST logo is a registered trademark of STMicroelectronics

© 2001 STMicroelectronics - Printed in Italy - All Rights Reserved
STMicroelectronics GROUP OF COMPANIES

Australia - Brazil - China - Finland - France - Germany - Hong Kong - India - Italy - Japan - Malaysia - Malta - Morocco
Singapore - Spain - Sweden - Switzerland - United Kingdom

© <http://www.st.com>

