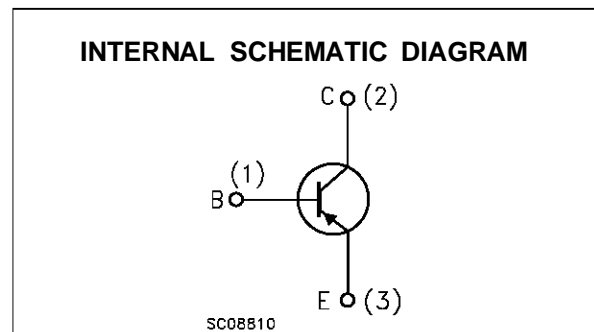
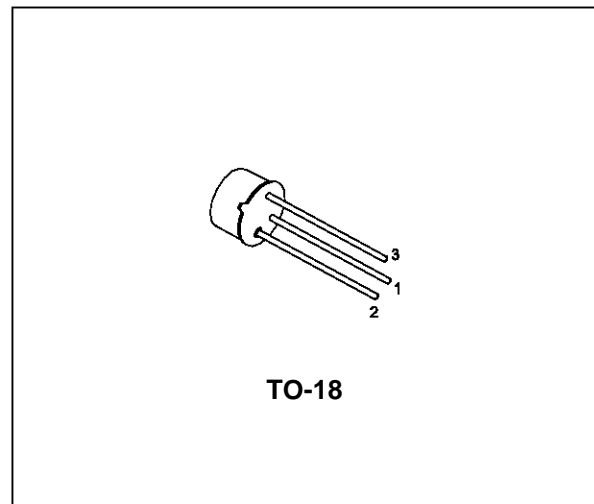

LOW NOISE AUDIO AMPLIFIERS

DESCRIPTION

The BCY79 is a silicon planar epitaxial PNP transistors in Jedec TO-18 metal case. They are designed for use in audio driver and low-noise input stages.

The complementary NPN type is the BCY59.

ABSOLUTE MAXIMUM RATINGS

Symbol	Parameter	Value	Unit
V_{CES}	Collector-Emitter Voltage ($V_{BE} = 0$)	-45	V
V_{CEO}	Collector-Emitter Voltage ($I_B = 0$)	-45	V
V_{EBO}	Emitter-Base Voltage ($I_C = 0$)	-5	V
I_C	Collector Current	-200	mA
I_{CM}	Collector Peak Current	-20	mA
P_{tot}	Total Dissipation at $T_{amb} \leq 25\text{ }^\circ\text{C}$ at $T_{case} \leq 45\text{ }^\circ\text{C}$	390	mW
		1	W
T_{stg}	Storage Temperature	-65 to 150	$^\circ\text{C}$
T_j	Max. Operating Junction Temperature	150	$^\circ\text{C}$

BCY79

THERMAL DATA

$R_{thj-case}$	Thermal Resistance Junction-Case	Max	150	$^{\circ}C/W$
$R_{thj-amb}$	Thermal Resistance Junction-Ambient	Max	450	$^{\circ}C/W$

ELECTRICAL CHARACTERISTICS ($T_{case} = 25^{\circ}C$ unless otherwise specified)

Symbol	Parameter	Test Conditions	Min.	Typ.	Max.	Unit
I_{CES}	Collector Cut-off Current ($V_{BE} = 0$)	$V_{CE} = -35 V$ $V_{CE} = -45 V$ $V_{CE} = -35 V$ $T_{amb} = 150^{\circ}C$		-2	-20 -100 -10	nA nA μA
I_{CEX}	Collector Cut-off Current ($V_{BE} = -2V$)	$V_{CE} = -45 V$ $T_{amb} = 100^{\circ}C$			-20	μA
I_{EBO}	Emitter Cut-off Current ($I_C = 0$)	$V_{EB} = -4 V$			-20	nA
$V_{(BR)CES}^*$	Collector-Emitter Breakdown Voltage ($V_{BE} = 0$)	$I_C = -10 \mu A$	-45			V
$V_{(BR)CEO}^*$	Collector-Emitter Breakdown Voltage ($I_B = 0$)	$I_C = -2 mA$	-45			V
$V_{(BR)EBO}$	Emitter-Base Breakdown Voltage ($I_C = 0$)	$I_E = -1 \mu A$	-5			V
$V_{CE(sat)}^*$	Collector-Emitter Saturation Voltage	$I_C = -10 mA$ $I_B = -0.25 mA$ $I_C = -100 mA$ $I_B = -2.5 mA$		-0.12 -0.4	-0.25 -0.8	V V
$V_{BE(sat)}^*$	Collector-Base Saturation Voltage	$I_C = -10 mA$ $I_B = -0.25 mA$ $I_C = -100 mA$ $I_B = -2.5 mA$	-0.6 -0.7	-0.7 -0.85	-0.85 -1.2	V V
$V_{BE(on)}^*$	Base-Emitter On Voltage	$I_C = -10 \mu A$ $V_{CE} = -5 V$ $I_C = -2 mA$ $V_{CE} = -5 V$ $I_C = -10 mA$ $V_{CE} = -1 V$ $I_C = -100 mA$ $V_{CE} = -1 V$	-0.6	-0.55 -0.65 -0.68 -0.75	-0.75	V V V V
h_{FE}^*	DC Current Gain	$I_C = -10 \mu A$ $V_{CE} = -5 V$ Gr. VII Gr. VIII Gr. IX $I_C = -2 mA$ $V_{CE} = -5 V$ Gr. VII Gr. VIII Gr. IX $I_C = -10 mA$ $V_{CE} = -1 V$ Gr. VII Gr. VIII Gr. IX $I_C = -100 mA$ $V_{CE} = -1 V$ Gr. VII Gr. VIII Gr. IX				
h_{fe}^*	Small Signal Current Gain	$I_C = -2 mA$ $V_{CE} = -5 V$ $f = 1KHz$ Gr. VII Gr. VIII Gr. IX	125 175 250	200 260 330	250 350 500	

* Pulsed: Pulse duration = 300 μs , duty cycle $\leq 2\%$

ELECTRICAL CHARACTERISTICS (continued)

Symbol	Parameter	Test Conditions	Min.	Typ.	Max.	Unit
f_T	Transition Frequency	$I_C = -10 \text{ mA}$ $V_{CE} = -5 \text{ V}$ $f = 100 \text{ MHz}$		180		MHz
C_{EBO}	Emitter Base Capacitance	$I_C = 0$ $V_{EB} = -0.5 \text{ V}$ $f = 1 \text{ MHz}$		11	15	pF
C_{CBO}	Collector Base Capacitance	$I_E = 0$ $V_{CB} = -10 \text{ V}$ $f = 1 \text{ MHz}$		4.5	7	pF
NF	Noise Figure	$I_C = -0.2 \text{ mA}$ $V_{CE} = -5 \text{ V}$ $f = 1 \text{ KHz}$ $R_g = 2 \text{ K}\Omega$		2	6	dB
h_{ie}	Input Impedance	$I_C = -2 \text{ mA}$ $V_{CE} = -5 \text{ V}$ $f = 1 \text{ KHz}$ Gr. VII Gr. VIII Gr. IX		2.7 3.6 4.5		$\text{K}\Omega$ $\text{K}\Omega$ $\text{K}\Omega$
h_{re}	Reverse Voltage Ratio	$I_C = -2 \text{ mA}$ $V_{CE} = -5 \text{ V}$ $f = 1 \text{ KHz}$ Gr. VII Gr. VIII Gr. IX		1.5 2 2		10^{-4} 10^{-4} 10^{-4}
h_{oe}	Output Admittance	$I_C = -2 \text{ mA}$ $V_{CE} = -5 \text{ V}$ $f = 1 \text{ KHz}$ Gr. VII Gr. VIII Gr. IX		18 24 30	30 50 60	μS μS μS
t_d	Delay Time	$V_{CC} = -10 \text{ V}$ $I_C = -10 \text{ mA}$ $I_{B1} = -1 \text{ mA}$ $I_C = -100 \text{ mA}$ $I_{B1} = -10 \text{ mA}$		35 5		ns ns
t_r	Rise Time	$V_{CC} = -10 \text{ V}$ $I_C = -10 \text{ mA}$ $I_{B1} = -1 \text{ mA}$ $I_C = -100 \text{ mA}$ $I_{B1} = -10 \text{ mA}$		50 50		ns ns
t_s	Storage Time	$V_{CC} = -10 \text{ V}$ $I_C = -10 \text{ mA}$ $I_{B1} = -I_{B2} = 1 \text{ mA}$ $I_C = -100 \text{ mA}$ $I_{B1} = -I_{B2} = 10 \text{ mA}$		400 250		ns ns
t_f	Fall Time	$V_{CC} = -10 \text{ V}$ $I_C = -10 \text{ mA}$ $I_{B1} = -I_{B2} = 1 \text{ mA}$ $I_C = -100 \text{ mA}$ $I_{B1} = -I_{B2} = 10 \text{ mA}$		80 200		ns ns
t_{on}	Turn-on Time	$V_{CC} = -10 \text{ V}$ $I_C = -10 \text{ mA}$ $I_{B1} = -1 \text{ mA}$ $I_C = -100 \text{ mA}$ $I_{B1} = -10 \text{ mA}$		85 55	150 150	ns ns
t_{off}	Turn-off Time	$V_{CC} = -10 \text{ V}$ $I_C = -10 \text{ mA}$ $I_{B1} = -I_{B2} = 1 \text{ mA}$ $I_C = -100 \text{ mA}$ $I_{B1} = -I_{B2} = 10 \text{ mA}$		480 450	800 800	ns ns

* Pulsed: Pulse duration = 300 μs , duty cycle $\leq 1\%$

Collector-emitter Saturation Voltage.

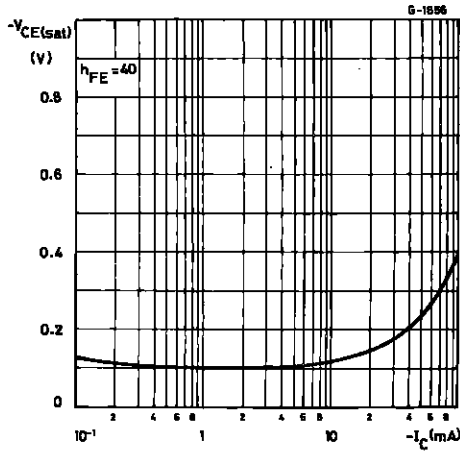

Base-emitter Saturation Voltage.

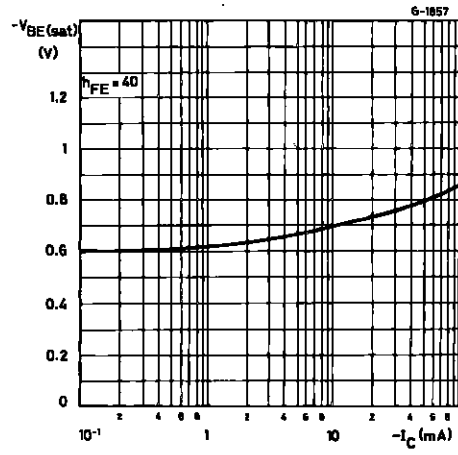

DC Current Gain.

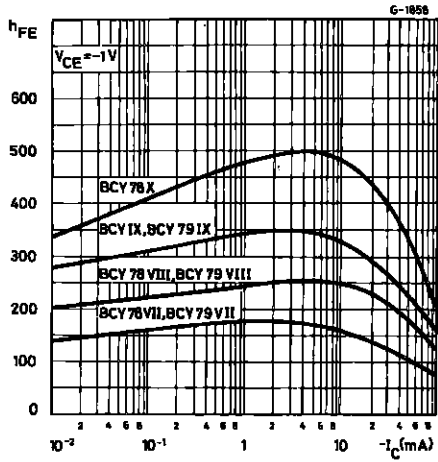

Normalized h Parameters.

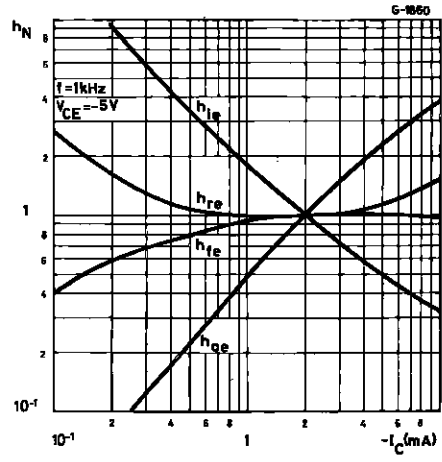

Noise Figure vs. Frequency.

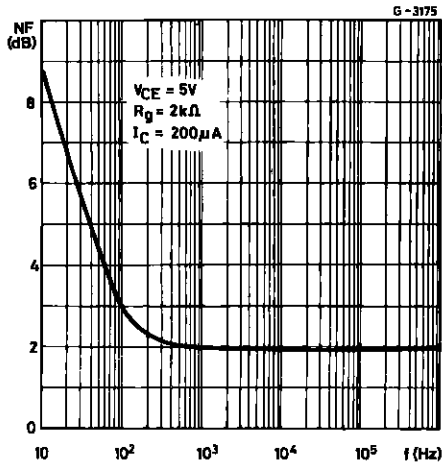

Noise Figure (f = 1 kHz).

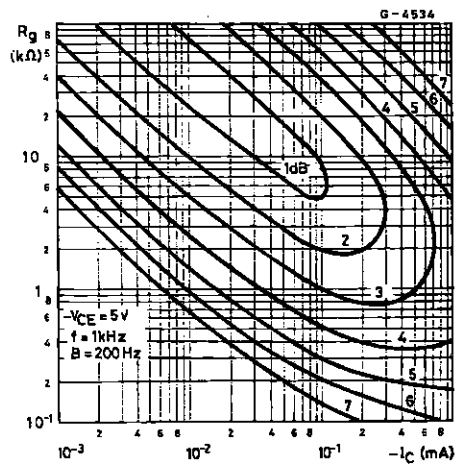

TO-18 MECHANICAL DATA

DIM.	mm			inch		
	MIN.	TYP.	MAX.	MIN.	TYP.	MAX.
A		12.7			0.500	
B			0.49			0.019
D			5.3			0.208
E			4.9			0.193
F			5.8			0.228
G	2.54			0.100		
H			1.2			0.047
I			1.16			0.045
L	45°			45°		

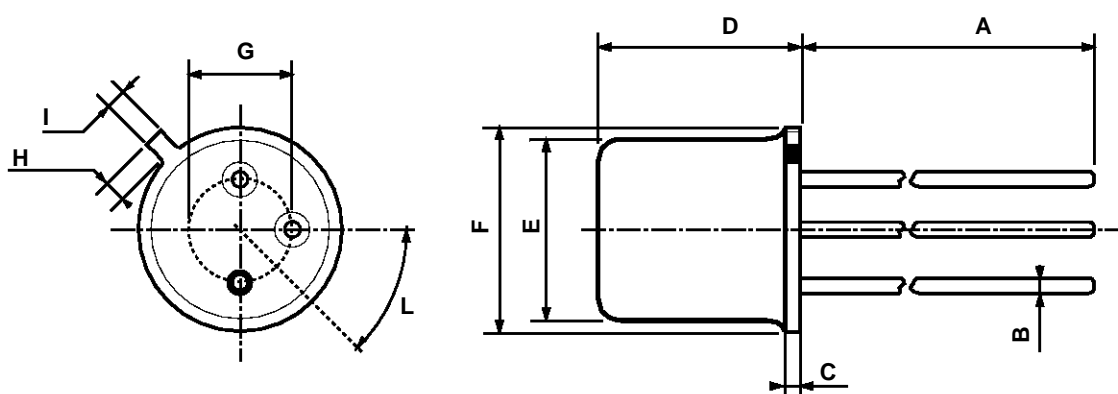

0016043

Information furnished is believed to be accurate and reliable. However, SGS-THOMSON Microelectronics assumes no responsibility for the consequences of use of such information nor for any infringement of patents or other rights of third parties which may result from its use. No license is granted by implication or otherwise under any patent or patent rights of SGS-THOMSON Microelectronics. Specifications mentioned in this publication are subject to change without notice. This publication supersedes and replaces all information previously supplied. SGS-THOMSON Microelectronics products are not authorized for use as critical components in life support devices or systems without express written approval of SGS-THOMSON Microelectronics.

© 1997 SGS-THOMSON Microelectronics - Printed in Italy - All Rights Reserved

SGS-THOMSON Microelectronics GROUP OF COMPANIES

Australia - Brazil - Canada - China - France - Germany - Italy - Japan - Korea - Malaysia - Malta - Morocco - The Netherlands -
Singapore - Spain - Sweden - Switzerland - Taiwan - Thailand - United Kingdom - U.S.A

...