



BUL1102E

HIGH VOLTAGE FAST-SWITCHING NPN POWER TRANSISTOR

PRELIMINARY DATA

- HIGH VOLTAGE CAPABILITY
- LOW SPREAD OF DYNAMIC PARAMETERS
- MINIMUM LOT-TO-LOT SPREAD FOR RELIABLE OPERATION
- VERY HIGH SWITCHING SPEED

APPLICATIONS

- FOUR LAMP ELECTRONIC BALLAST FOR:
120 V MAINS IN PUSH-PULL CONFIGURATION;
277 V MAINS IN HALF BRIDGE CURRENT FEED CONFIGURATION.

DESCRIPTION

The device is manufactured using high voltage Multi Epitaxial Planar technology for high switching speeds and high voltage capability. It uses a Cellular Emitter structure with planar edge termination to enhance switching speeds while maintaining a wide RBSOA.

Thanks to an increased intermediate layer, it has an intrinsic ruggedness which enables the transistor to withstand a high collector current level during Breakdown condition, without using the transil protection usually necessary in typical converters for lamp ballast.

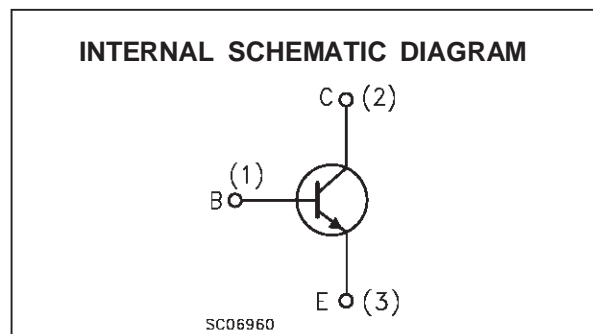
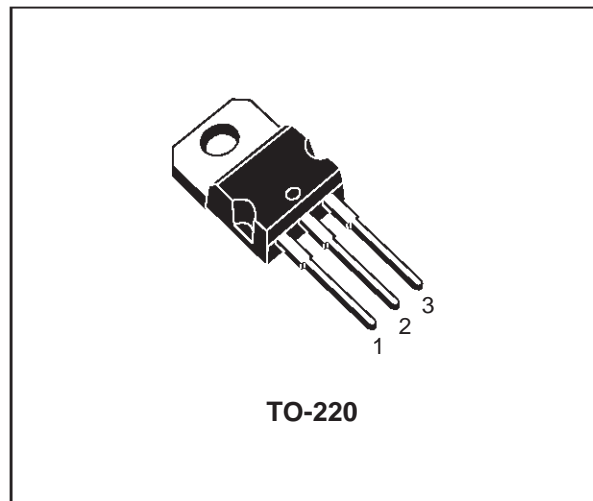

ABSOLUTE MAXIMUM RATINGS

Symbol	Parameter	Value	Unit
V_{CES}	Collector-Emitter Voltage ($V_{BE} = 0$)	1100	V
V_{CEO}	Collector-Emitter Voltage ($I_B = 0$)	450	V
V_{EBO}	Emitter-Base Voltage ($I_C = 0$)	12	V
I_C	Collector Current	4	A
I_{CM}	Collector Peak Current ($t_p < 5$ ms)	8	A
I_B	Base Current	2	A
I_{BM}	Base Peak Current ($t_p < 5$ ms)	4	A
P_{tot}	Total Dissipation at $T_c = 25$ °C	70	W
T_{stg}	Storage Temperature	-65 to 150	°C
T_j	Max. Operating Junction Temperature	150	°C

THERMAL DATA

R _{thj-case}	Thermal Resistance Junction-Case	Max	1.78	°C/W
-----------------------	----------------------------------	-----	------	------

ELECTRICAL CHARACTERISTICS (T_{case} = 25 °C unless otherwise specified)

Symbol	Parameter	Test Conditions	Min.	Typ.	Max.	Unit
I _{CES}	Collector Cut-off Current (V _{BE} = 0)	V _{CE} = 1100 V			100	μA
I _{EBO}	Emitter Cut-off Current (I _B = 0)	V _{EB} = 12 V			1	mA
V _{CEO(sus)*}	Collector-Emitter Sustaining Voltage (I _B = 0)	I _C = 100 mA	450			V
V _{CE(sat)*}	Collector-Emitter Saturation Voltage	I _C = 2 A I _B = 400 mA			1.5	V
V _{BE(sat)*}	Base-Emitter Saturation Voltage	I _C = 2 A I _B = 400 mA			1.5	V
h _{FE*}	DC Current Gain	I _C = 250 mA V _{CE} = 5 V I _C = 2 A V _{CE} = 5 V	35 10		70 20	
t _s t _f	RESISTIVE LOAD Storage Time Fall Time	I _C = 2.5 A V _{CC} = 250 V I _{B1} = 0.5 A I _{B2} = 1 A T _P = 30 μs (see figure 2)			2.5 300	μs ns
E _{sb}	Avalanche Energy	L = 2 mH C = 1.8 nF I _{BR} ≤ 2.5A 25°C < T _C < 125°C (see figure 1)	6			mJ

* Pulsed: Pulse duration = 300 μs, duty cycle 1.5%

Safe Operating Areas

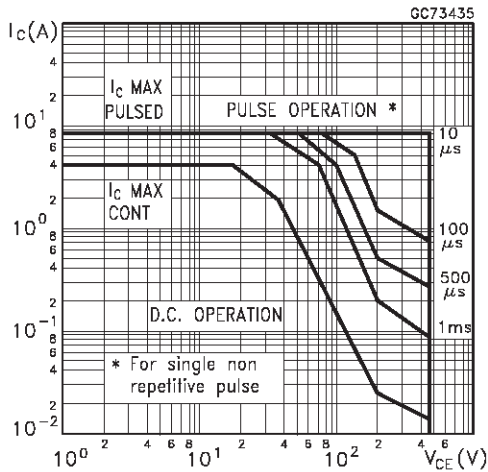

Derating Curve

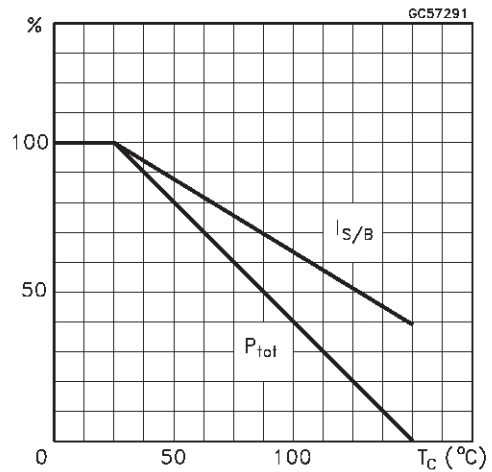

Reverse Biased SOA

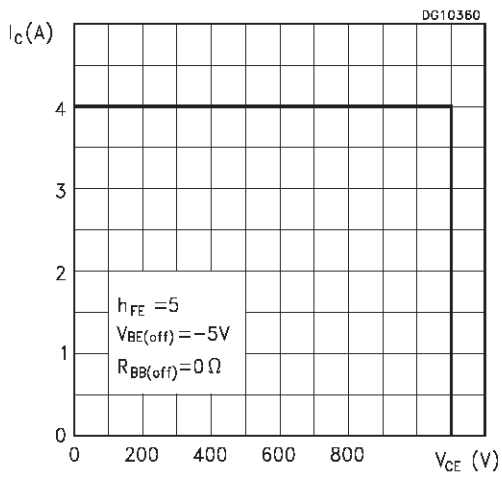

Figure 1: Energy Rating Test Circuit

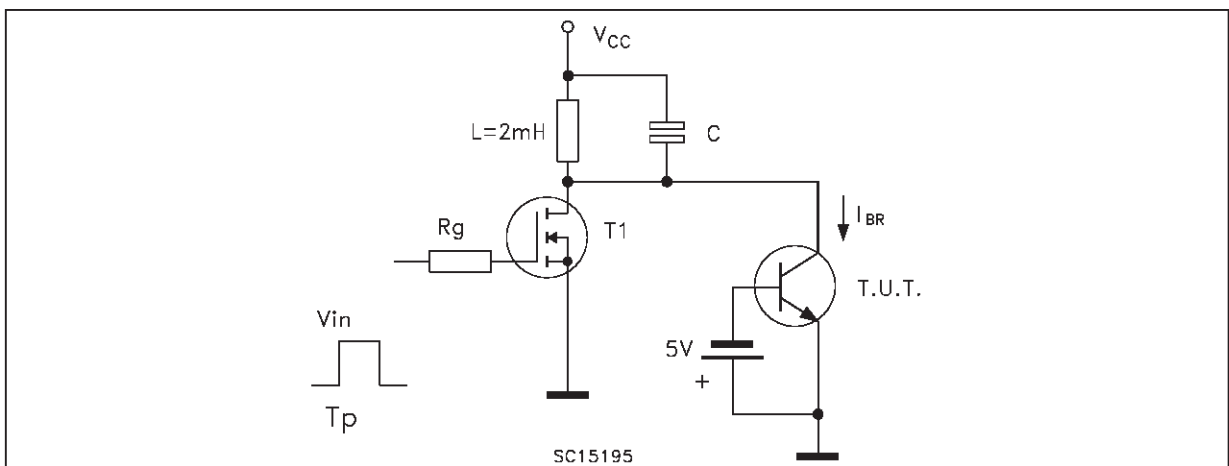
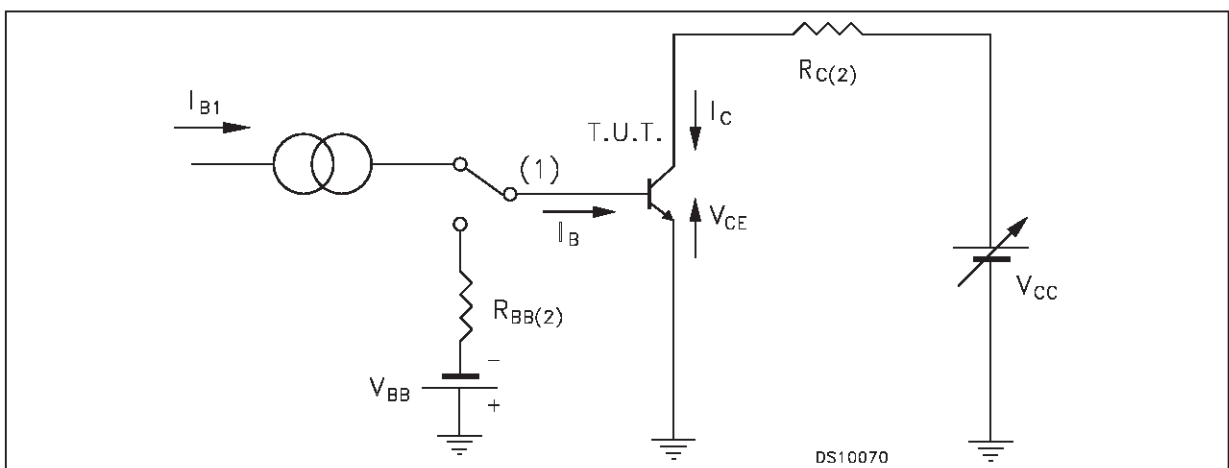
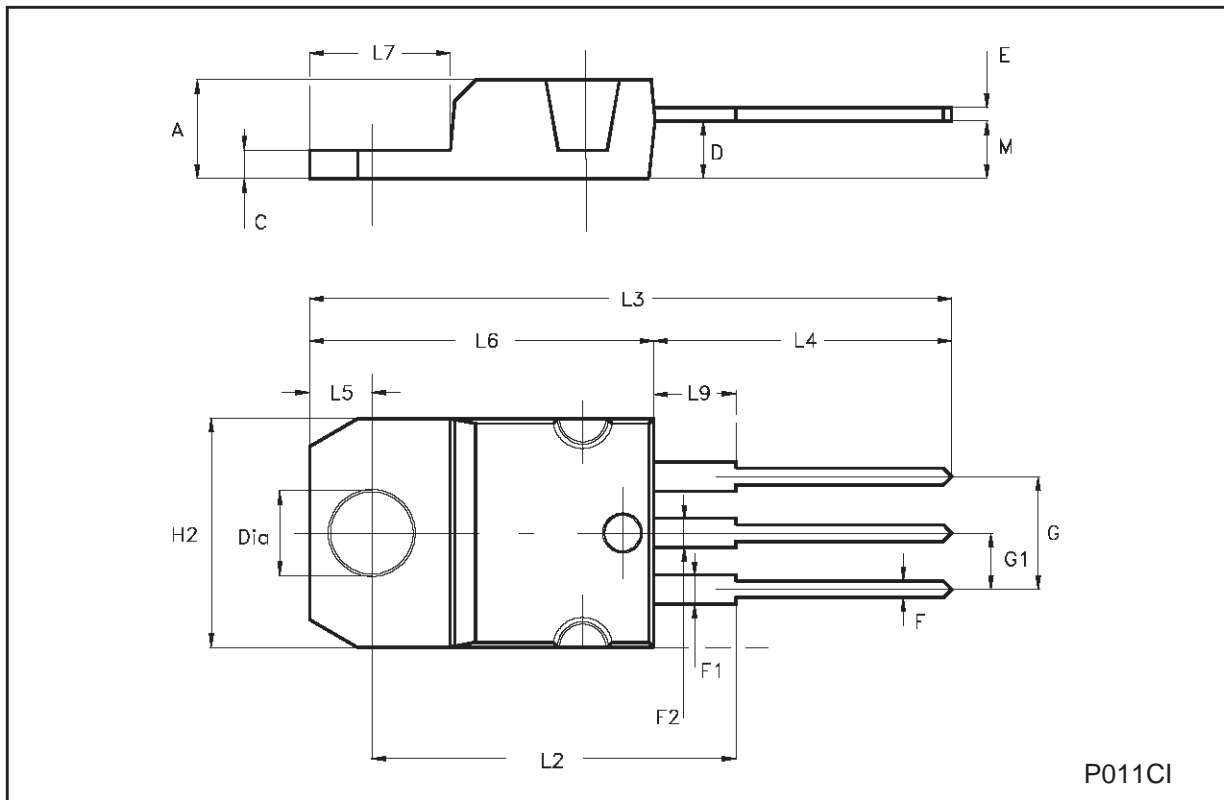

Figure 2: Resistive Load Switching Test Circuit



TO-220 MECHANICAL DATA

DIM.	mm			inch		
	MIN.	TYP.	MAX.	MIN.	TYP.	MAX.
A	4.40		4.60	0.173		0.181
C	1.23		1.32	0.048		0.052
D	2.40		2.72	0.094		0.107
E	0.49		0.70	0.019		0.027
F	0.61		0.88	0.024		0.034
F1	1.14		1.70	0.044		0.067
F2	1.14		1.70	0.044		0.067
G	4.95		5.15	0.194		0.202
G1	2.40		2.70	0.094		0.106
H2	10.00		10.40	0.394		0.409
L2		16.40			0.645	
L4	13.00		14.00	0.511		0.551
L5	2.65		2.95	0.104		0.116
L6	15.25		15.75	0.600		0.620
L7	6.20		6.60	0.244		0.260
L9	3.50		3.93	0.137		0.154
M		2.60			0.102	
DIA.	3.75		3.85	0.147		0.151



Information furnished is believed to be accurate and reliable. However, STMicroelectronics assumes no responsibility for the consequences of use of such information nor for any infringement of patents or other rights of third parties which may result from its use. No license is granted by implication or otherwise under any patent or patent rights of STMicroelectronics. Specification mentioned in this publication are subject to change without notice. This publication supersedes and replaces all information previously supplied. STMicroelectronics products are not authorized for use as critical components in life support devices or systems without express written approval of STMicroelectronics.

The ST logo is a trademark of STMicroelectronics

© 2002 STMicroelectronics – Printed in Italy – All Rights Reserved

STMicroelectronics GROUP OF COMPANIES

Australia - Brazil - Canada - China - Finland - France - Germany - Hong Kong - India - Israel - Italy - Japan - Malaysia - Malta - Morocco - Singapore - Spain - Sweden - Switzerland - United Kingdom - United States.

<http://www.st.com>

