



BUL903ED

HIGH VOLTAGE FAST-SWITCHING NPN POWER TRANSISTOR

- INTEGRATED ANTISATURATION AND PROTECTION NETWORK
- INTEGRATED ANTIPARALLEL COLLECTOR EMITTER DIODE
- HIGH VOLTAGE CAPABILITY
- LOW SPREAD OF DYNAMIC PARAMETERS
- MINIMUM LOT-TO-LOT SPREAD FOR RELIABLE OPERATION
- VERY HIGH SWITCHING SPEED
- ARCING TEST SELF PROTECTED

APPLICATIONS

- LAMP ELECTRONIC BALLAST FOR FLUORESCENT LIGHTING USING 277V HALF BRIDGE CURRENT-FED CONFIGURATION

DESCRIPTION

The BUL903ED is manufactured using high voltage Multi Epitaxial Planar technology for high switching speeds and high voltage capability.

The device has been designed to operate without baker clamp and transil protection. This enables saving from 2 up to 10 components in the application.

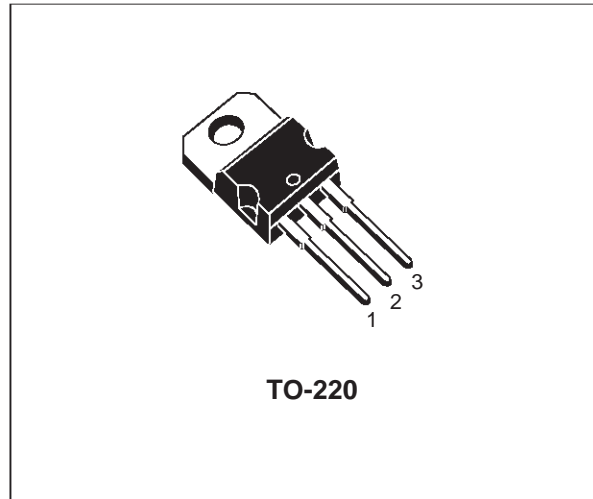

TO-220

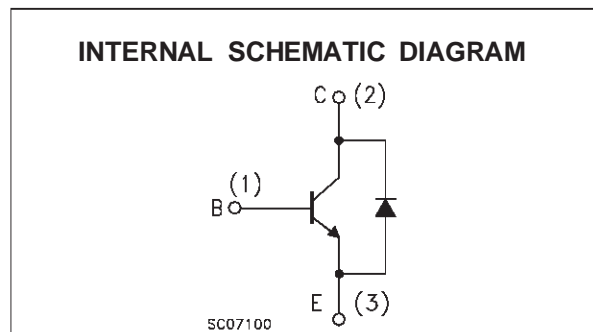

ABSOLUTE MAXIMUM RATINGS

Symbol	Parameter	Value	Unit
V_{CES}	Collector-Emitter Voltage ($V_{BE} = 0$)	900	V
V_{CEO}	Collector-Emitter Voltage ($I_B = 0$)	400	V
V_{EBO}	Emitter-Base Voltage ($I_C = 0$)	7	V
I_C	Collector Current	5	A
I_{CM}	Collector Peak Current ($t_p < 5$ ms)	8	A
I_B	Base Current	2	A
I_{BM}	Base Peak Current ($t_p < 5$ ms)	4	A
P_{tot}	Total Dissipation at $T_c = 25$ °C	70	W
T_{stg}	Storage Temperature	-65 to 150	°C
T_j	Max. Operating Junction Temperature	150	°C

BUL903ED

THERMAL DATA

R _{thj-case}	Thermal Resistance Junction-Case	Max	1.8	°C/W
R _{thj-amb}	Thermal Resistance Junction-Ambient	Max	62.5	°C/W

ELECTRICAL CHARACTERISTICS (T_{case} = 25 °C unless otherwise specified)

Symbol	Parameter	Test Conditions	Min.	Typ.	Max.	Unit
I _{CEs}	Collector Cut-off Current (V _{BE} = 0)	V _{CE} = 900 V			1	mA
I _{EBO}	Base-Emitter Leakage Current	V _{EB} = 7 V			100	μA
V _{CEO(sus)*}	Collector-Emitter Sustaining Voltage (I _B = 0)	I _C = 10 mA L = 25 mH	400			V
V _{CE(sat)*}	Collector-Emitter Saturation Voltage	I _C = 1 A I _B = 0.15 A			1.0	V
V _{BE(sat)*}	Base-Emitter Saturation Voltage	I _C = 0.1 A I _B = 0.05 A I _C = 0.5 A I _B = 0.1 A I _C = 2.0 A I _B = 0.4 A			1.0 1.1 1.2	V V V
h _{FE*}	DC Current Gain	I _C = 5 mA V _{CE} = 10 V I _C = 0.5 A V _{CE} = 3 V	8 20			
V _F	Parallel Diode Forward Voltage	I _F = 3 A			1.2	V
t _d t _r t _s t _f	RESISTIVE LOAD Delay Time Rise Time Storage Time Fall Time	V _{CC} = 125 V I _C = 0.7 A I _{B1} = 0.05 A I _{B2} = 0.4 A t _p = 300 μs			0.2 1.0 0.8 0.25	μs μs μs μs
t _d t _r t _s t _f	RESISTIVE LOAD Delay Time Rise Time Storage Time Fall Time	V _{CC} = 125 V I _C = 0.5 A I _{B1} = 0.045 A I _{B2} = 0.5 A t _p = 300 μs			0.2 0.5 0.8 0.5	μs μs μs μs
T _{RR}	Diode Reverse Recovery Time	I _F = 1 A di/dt = 100 A/μs V _{DD} = 30 V		300		ns
E _{sb}	Avalanche Energy	L = 2 mH	6			mJ

* Pulsed: Pulse duration = 300 μs, duty cycle 1.5 %

Safe Operating Areas

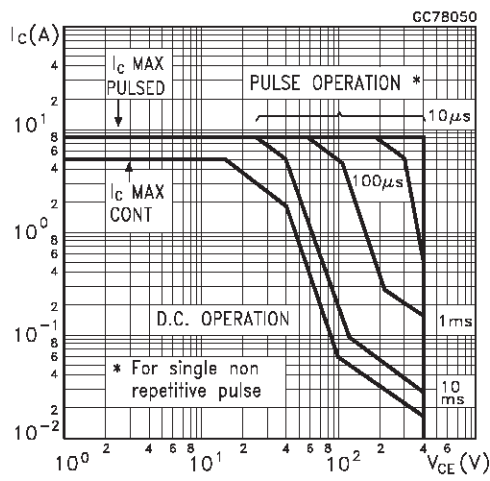

Derating Curve

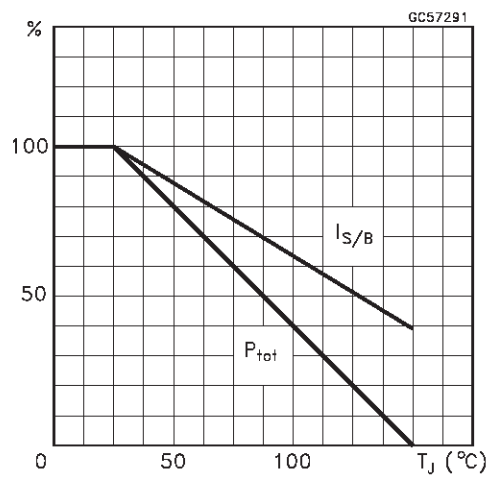

DC Current Gain

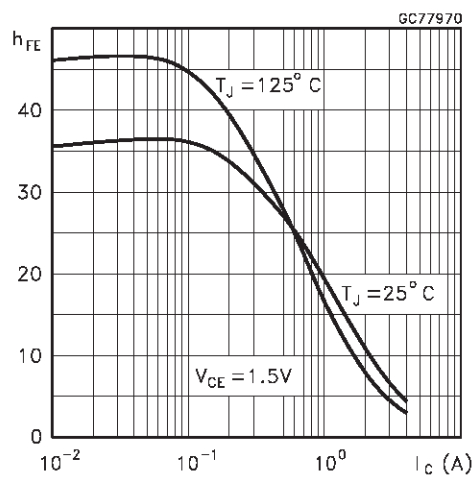

DC Current Gain

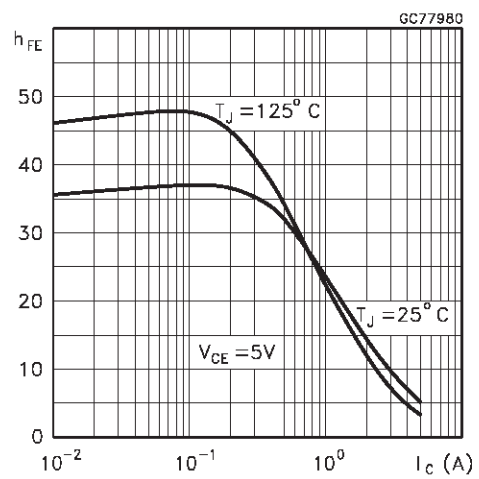

Collector Emitter Saturation Voltage

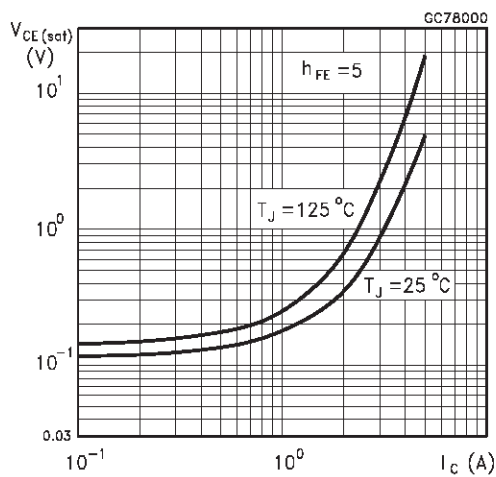

Base Emitter Saturation Voltage

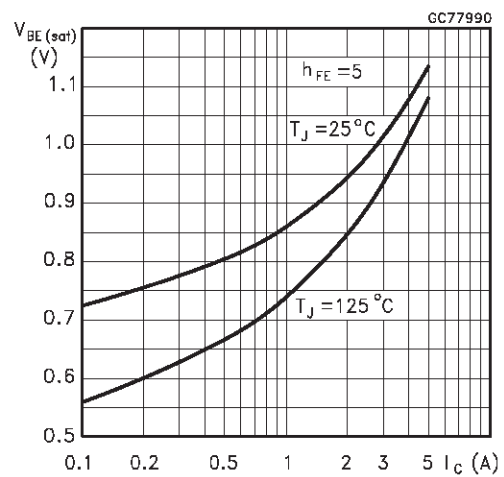

BUL903ED

Reverse Biased SOA

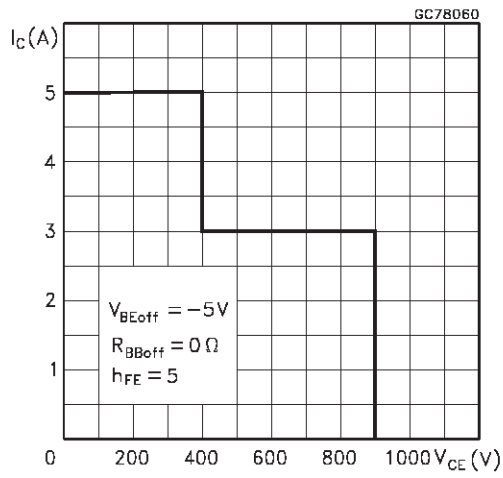

Resistive Load Switching Test Circuit

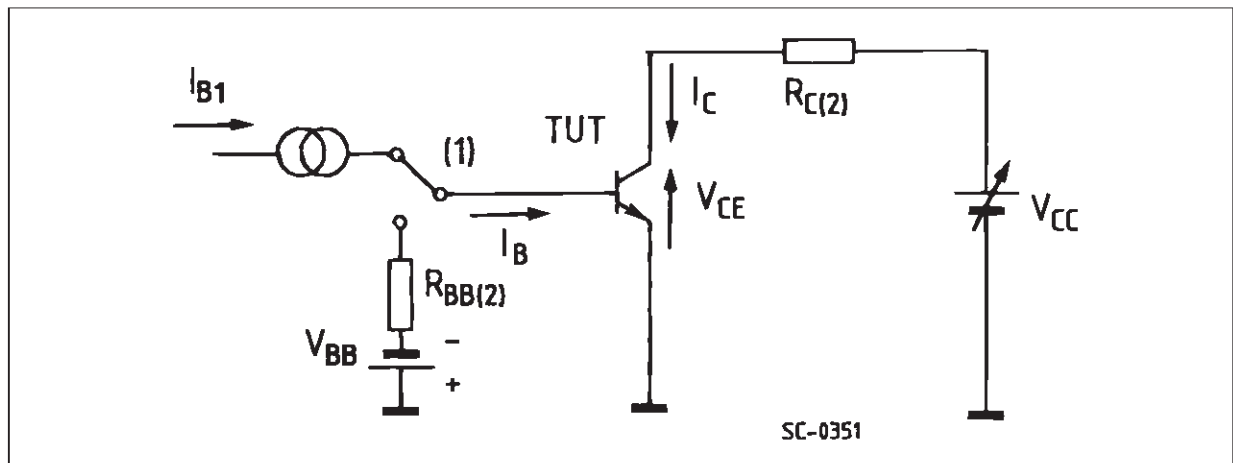

Energy Rating Test Circuit

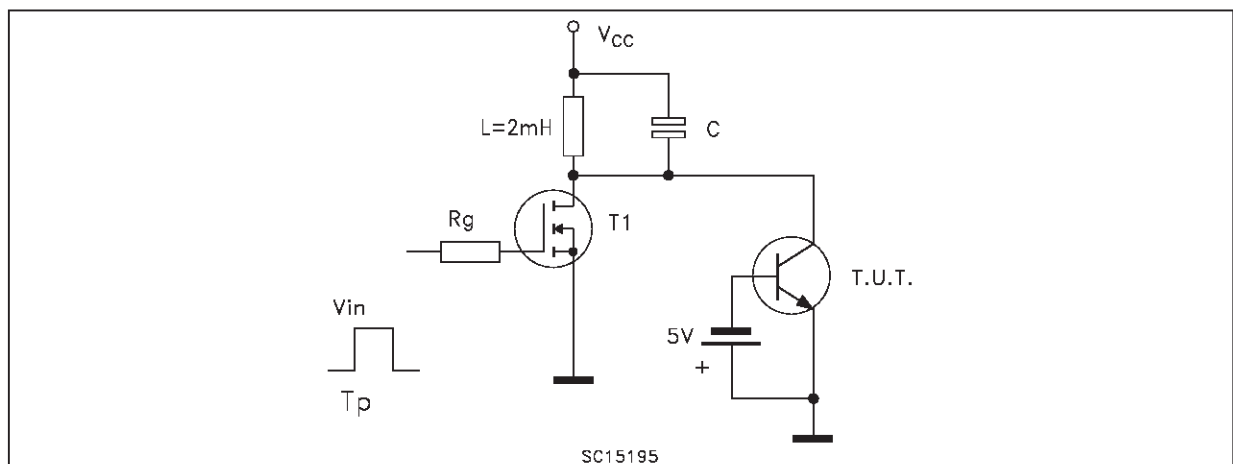

TO-220 MECHANICAL DATA

DIM.	mm			inch		
	MIN.	TYP.	MAX.	MIN.	TYP.	MAX.
A	4.40		4.60	0.173		0.181
C	1.23		1.32	0.048		0.051
D	2.40		2.72	0.094		0.107
D1		1.27			0.050	
E	0.49		0.70	0.019		0.027
F	0.61		0.88	0.024		0.034
F1	1.14		1.70	0.044		0.067
F2	1.14		1.70	0.044		0.067
G	4.95		5.15	0.194		0.203
G1	2.4		2.7	0.094		0.106
H2	10.0		10.40	0.393		0.409
L2		16.4			0.645	
L4	13.0		14.0	0.511		0.551
L5	2.65		2.95	0.104		0.116
L6	15.25		15.75	0.600		0.620
L7	6.2		6.6	0.244		0.260
L9	3.5		3.93	0.137		0.154
DIA.	3.75		3.85	0.147		0.151

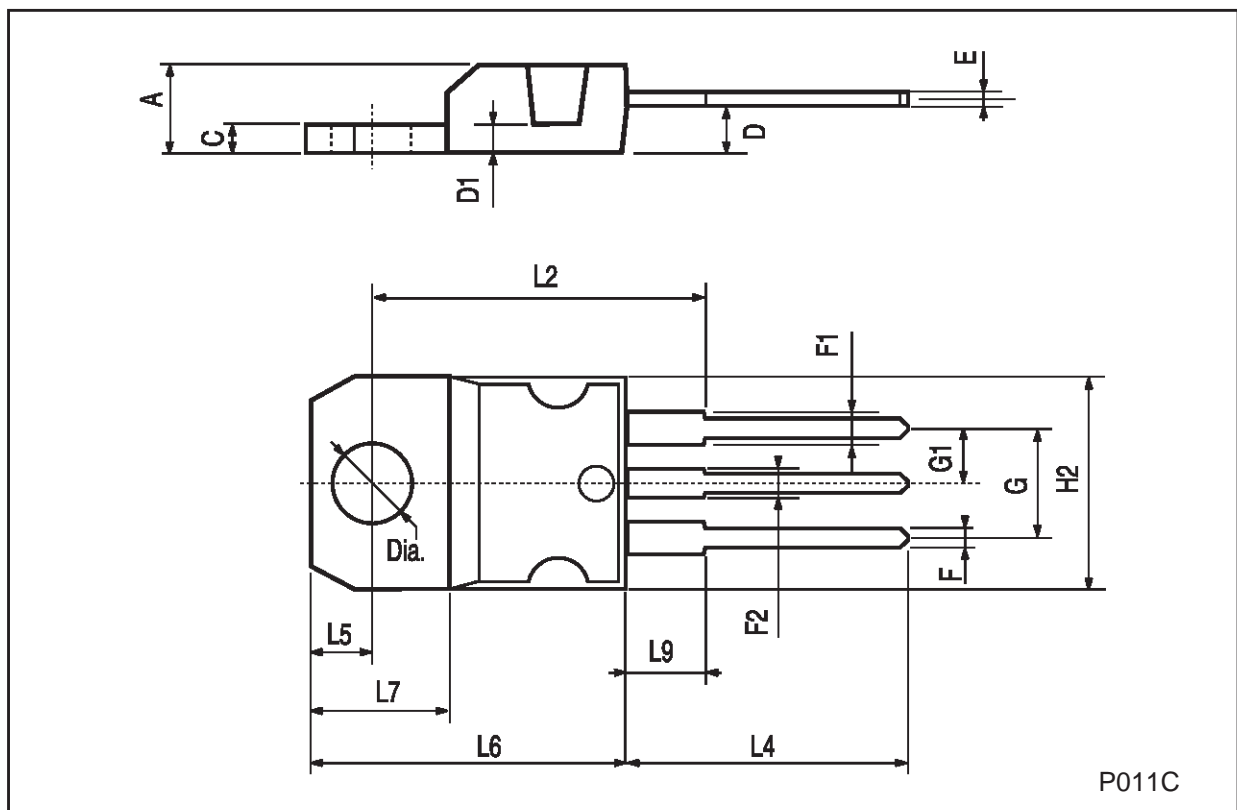

Information furnished is believed to be accurate and reliable. However, STMicroelectronics assumes no responsibility for the consequences of use of such information nor for any infringement of patents or other rights of third parties which may result from its use. No license is granted by implication or otherwise under any patent or patent rights of STMicroelectronics. Specification mentioned in this publication are subject to change without notice. This publication supersedes and replaces all information previously supplied. STMicroelectronics products are not authorized for use as critical components in life support devices or systems without express written approval of STMicroelectronics.

The ST logo is a trademark of STMicroelectronics

© 2001 STMicroelectronics – Printed in Italy – All Rights Reserved

STMicroelectronics GROUP OF COMPANIES

Australia - Brazil - China - Finland - France - Germany - Hong Kong - India - Italy - Japan - Malaysia - Malta - Morocco - Singapore - Spain - Sweden - Switzerland - United Kingdom - U.S.A.

<http://www.st.com>