



# IRF634 IRF634FP

## N-CHANNEL 250V - 0.38Ω - 8A TO-220/TO-220FP MESH OVERLAY™ MOSFET

TYPE	V <sub>DSS</sub>	R <sub>DS(on)</sub>	I <sub>D</sub>
IRF634	250 V	< 0.45 Ω	8 A
IRF634FP	250 V	< 0.45 Ω	8 A

- TYPICAL R<sub>DS(on)</sub> = 0.38 Ω
- EXTREMELY HIGH dv/dt CAPABILITY
- 100% AVALANCHE TESTED

### DESCRIPTION

Using the latest high voltage MESH OVERLAY™ process, STMicroelectronics has designed an advanced family of power MOSFETs with outstanding performance. The new patented STRIP layout coupled with the Company's proprietary edge termination structure, makes it suitable in converters for lighting applications.

### APPLICATIONS

- HIGH CURRENT, HIGH SPEED SWITCHING
- SWITCH MODE POWER SUPPLIES (SMPS)
- DC-DC CONVERTERS FOR TELECOM, INDUSTRIAL, AND LIGHTING EQUIPMENT
- IDEAL FOR MONITOR'S B+ FUNCTION

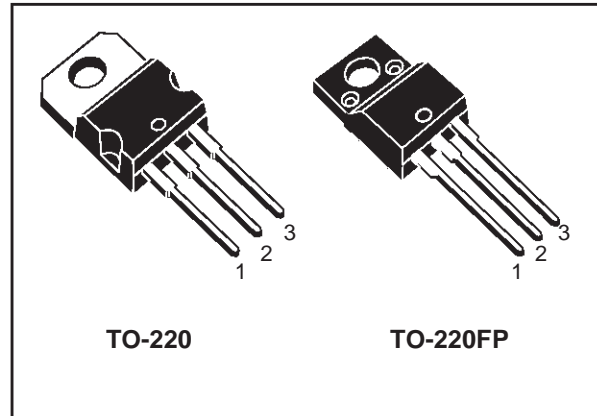

### INTERNAL SCHEMATIC DIAGRAM

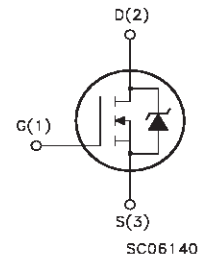

### ABSOLUTE MAXIMUM RATINGS

Symbol	Parameter	Value		Unit
		IRF634	IRF634FP	
V <sub>DS</sub>	Drain-source Voltage (V <sub>GS</sub> = 0)	250		V
V <sub>DGR</sub>	Drain-gate Voltage (R <sub>GS</sub> = 20 kΩ)	250		V
V <sub>GS</sub>	Gate- source Voltage	± 20		V
I <sub>D</sub>	Drain Current (continuous) at T <sub>C</sub> = 25°C	8	8(*)	A
I <sub>D</sub>	Drain Current (continuous) at T <sub>C</sub> = 100°C	5	5(*)	A
I <sub>DM</sub> (●)	Drain Current (pulsed)	32	32(*)	A
P <sub>TOT</sub>	Total Dissipation at T <sub>C</sub> = 25°C	80	30	W
	Derating Factor	0.64	0.24	W/°C
dv/dt (1)	Peak Diode Recovery voltage slope	5		V/ns
V <sub>ISO</sub>	Insulation Withstand Voltage (DC)	-	2000	V
T <sub>stg</sub>	Storage Temperature	-65 to 150		°C
T <sub>j</sub>	Max. Operating Junction Temperature	150		°C

(●)Pulse width limited by safe operating area

(1) I<sub>SD</sub> ≤ 8A, di/dt ≤ 300 A/μs, V<sub>DD</sub> ≤ V(BR)DSS, T<sub>J</sub> ≤ T<sub>J</sub>MAX  
(\*)Limited only by maximum temperature allowed

## IRF634/IRF634FP

### THERMAL DATA

		TO-220	TO-220FP	
Rthj-case	Thermal Resistance Junction-case Max	1.56	4.11	°C/W
Rthj-amb	Thermal Resistance Junction-ambient Max	62.5		°C/W
T <sub>l</sub>	Maximum Lead Temperature For Soldering Purpose	300		°C

### AVALANCHE CHARACTERISTICS

Symbol	Parameter	Max Value	Unit
I <sub>AR</sub>	Avalanche Current, Repetitive or Not-Repetitive (pulse width limited by T <sub>j</sub> max)	8	A
E <sub>AS</sub>	Single Pulse Avalanche Energy (starting T <sub>j</sub> = 25 °C, I <sub>D</sub> = I <sub>AR</sub> , V <sub>DD</sub> = 50 V)	300	mJ

### ELECTRICAL CHARACTERISTICS (TCASE = 25 °C UNLESS OTHERWISE SPECIFIED)

OFF

Symbol	Parameter	Test Conditions	Min.	Typ.	Max.	Unit
V <sub>(BR)DSS</sub>	Drain-source Breakdown Voltage	I <sub>D</sub> = 250 μA, V <sub>GS</sub> = 0	250			V
I <sub>DSS</sub>	Zero Gate Voltage Drain Current (V <sub>GS</sub> = 0)	V <sub>DS</sub> = Max Rating V <sub>DS</sub> = Max Rating, T <sub>C</sub> = 125 °C			1 10	μA μA
I <sub>GSS</sub>	Gate-body Leakage Current (V <sub>DS</sub> = 0)	V <sub>GS</sub> = ±20V			±100	nA

ON (1)

Symbol	Parameter	Test Conditions	Min.	Typ.	Max.	Unit
V <sub>GS(th)</sub>	Gate Threshold Voltage	V <sub>DS</sub> = V <sub>GS</sub> , I <sub>D</sub> = 250μA	2	3	4	V
R <sub>DS(on)</sub>	Static Drain-source On Resistance	V <sub>GS</sub> = 10V, I <sub>D</sub> = 4 A		0.38	0.45	Ω

DYNAMIC

Symbol	Parameter	Test Conditions	Min.	Typ.	Max.	Unit
g <sub>fs</sub> (1)	Forward Transconductance	V <sub>DS</sub> > I <sub>D(on)</sub> × R <sub>DS(on)max</sub> , I <sub>D</sub> = 4A	7	8		S
C <sub>iss</sub>	Input Capacitance	V <sub>DS</sub> = 25V, f = 1 MHz, V <sub>GS</sub> = 0		770		pF
C <sub>oss</sub>	Output Capacitance			118		pF
C <sub>rss</sub>	Reverse Transfer Capacitance			48		pF

**ELECTRICAL CHARACTERISTICS (CONTINUED)**

**SWITCHING ON**

Symbol	Parameter	Test Conditions	Min.	Typ.	Max.	Unit
$t_{d(on)}$	Turn-on Delay Time	$V_{DD} = 125\text{ V}, I_D = 4\text{ A}$ $R_G = 4.7\Omega, V_{GS} = 10\text{ V}$ (see test circuit, Figure 3)		13		ns
$t_r$	Rise Time			18		ns
$Q_g$	Total Gate Charge	$V_{DD} = 200\text{ V}, I_D = 8\text{ A},$ $V_{GS} = 10\text{ V}$		37	51.8	nC
$Q_{gs}$	Gate-Source Charge			5.2		nC
$Q_{gd}$	Gate-Drain Charge			14.8		nC

**SWITCHING OFF**

Symbol	Parameter	Test Conditions	Min.	Typ.	Max.	Unit
$t_{d(Voff)}$	Turn-off- Delay Time	$V_{DD} = 125\text{ V}, I_D = 4\text{ A},$ $R_G = 4.7\Omega, V_{GS} = 10\text{ V}$ (see test circuit, Figure 3)		51		ns
$t_f$	Fall Time			16		ns
$t_{r(Voff)}$	Off-voltage Rise Time	$V_{clamp} = 200\text{ V}, I_D = 8\text{ A},$ $R_G = 4.7\Omega, V_{GS} = 10\text{ V}$ (see test circuit, Figure 5)		12.5		ns
$t_f$	Fall Time			12.5		ns
$t_c$	Cross-over Time			28		ns

**SOURCE DRAIN DIODE**

Symbol	Parameter	Test Conditions	Min.	Typ.	Max.	Unit
$I_{SD}$	Source-drain Current				8	A
$I_{SDM(2)}$	Source-drain Current (pulsed)				32	A
$V_{SD(1)}$	Forward On Voltage	$I_{SD} = 8\text{ A}, V_{GS} = 0$			1.7	V
$t_{rr}$	Reverse Recovery Time	$I_{SD} = 8\text{ A}, di/dt = 100\text{ A}/\mu\text{s}$ $V_{DD} = 30\text{ V}, T_J = 150^\circ\text{C}$ (see test circuit, Figure 5)		198		ns
$Q_{rr}$	Reverse Recovery Charge			1.1		$\mu\text{C}$
$I_{RRM}$	Reverse Recovery Current			11.3		A

Note: 1. Pulsed: Pulse duration = 300  $\mu\text{s}$ , duty cycle 1.5 %.  
2. Pulse width limited by safe operating area.

**Safe Operating Area for TO-220**

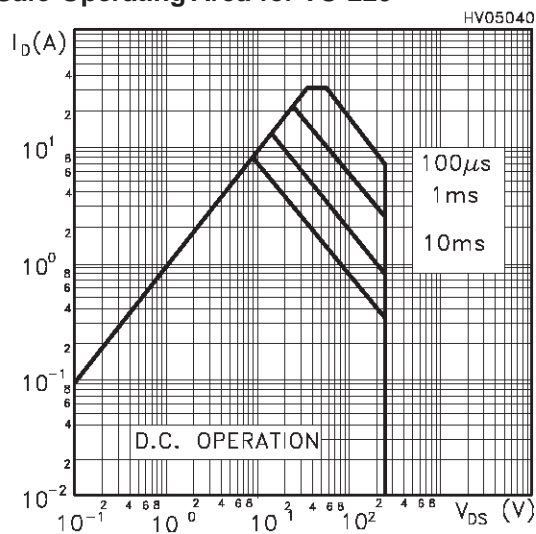

**Safe Operating Area for TO-220FP**

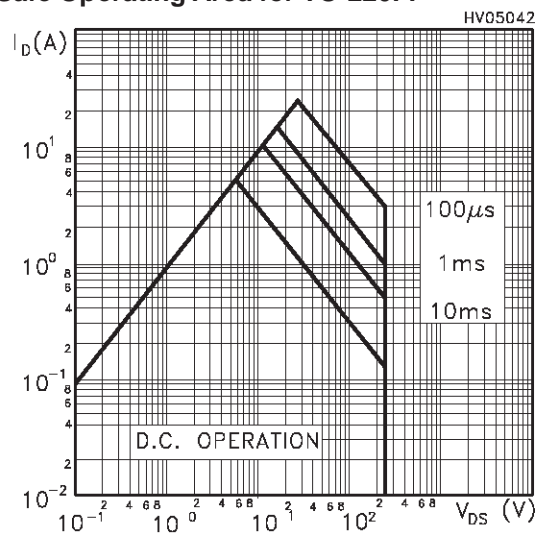

Thermal Impedance for TO-220

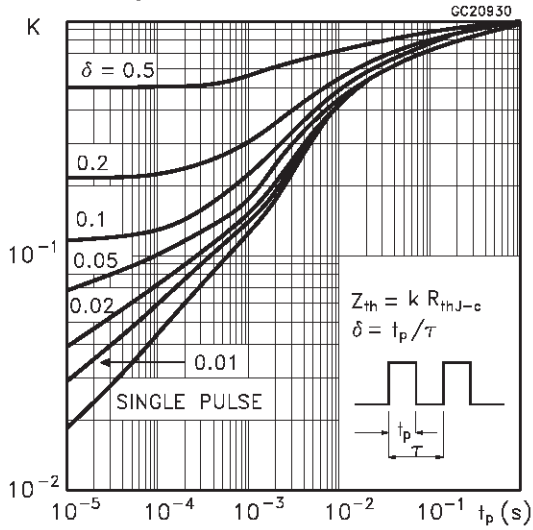

Thermal Impedance for TO-220FP

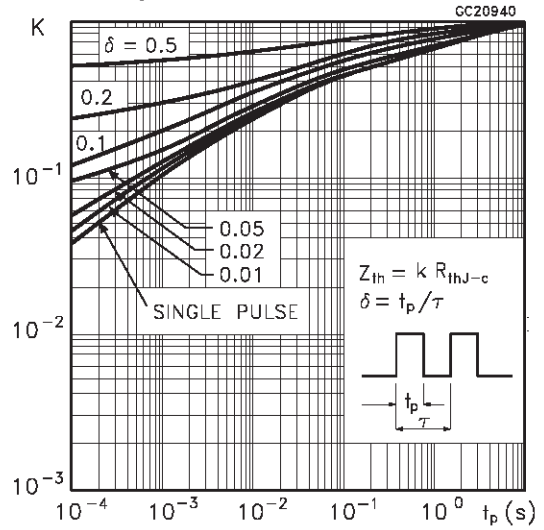

Output Characteristics

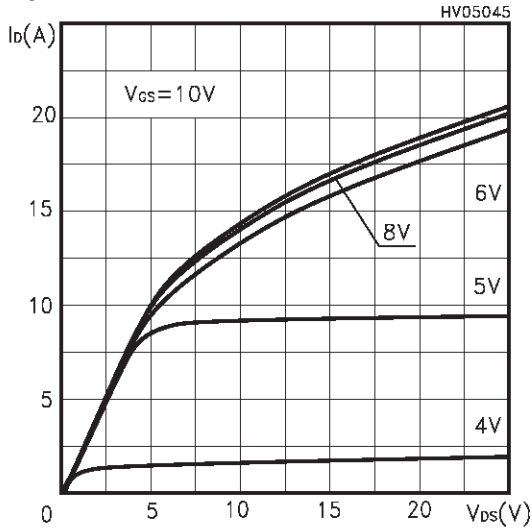

Transfer Characteristics

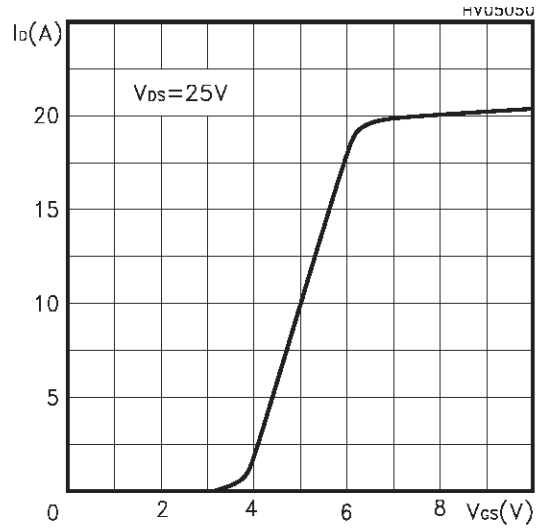

Transconductance

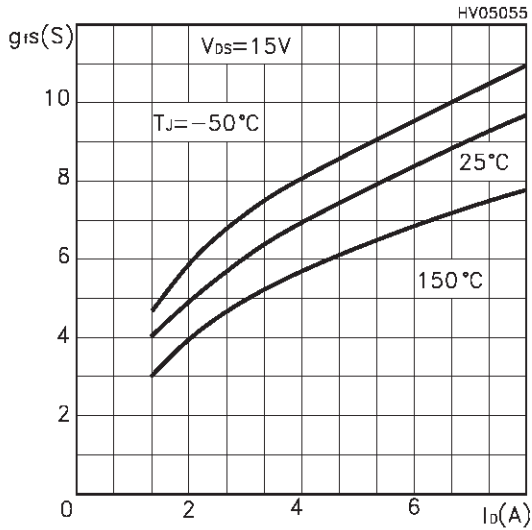

Static Drain-source On Resistance

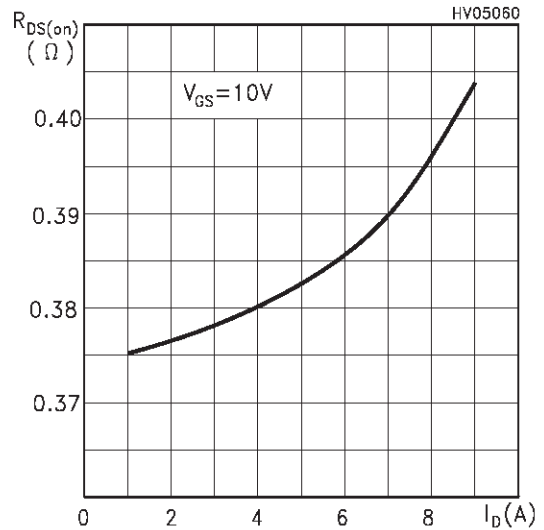

**Gate Charge vs Gate-source Voltage**

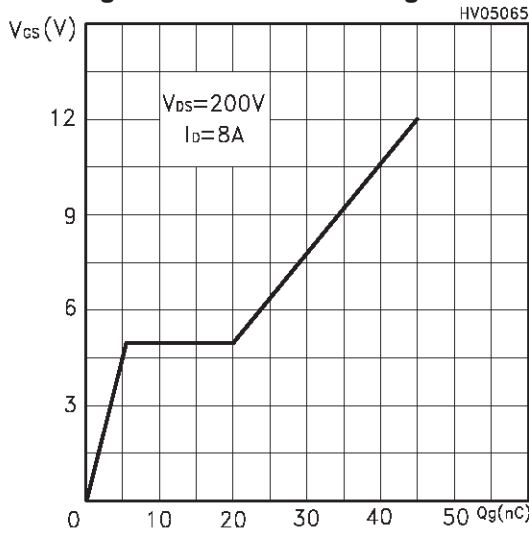

**Normalized Gate Threshold Voltage vs Temp.**

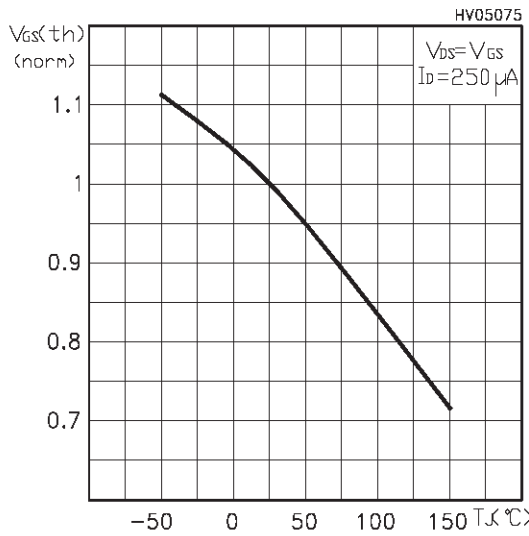

**Source-drain Diode Forward Characteristics**

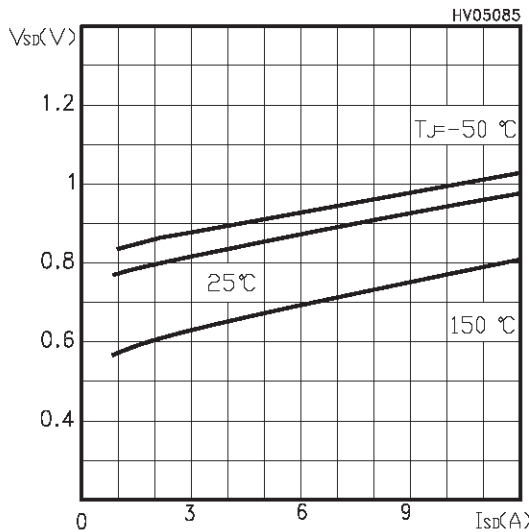

**Capacitance Variations**

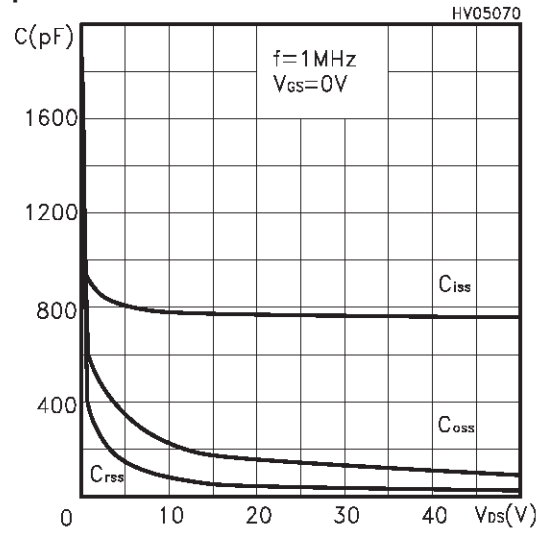

**Normalized On Resistance vs Temperature**

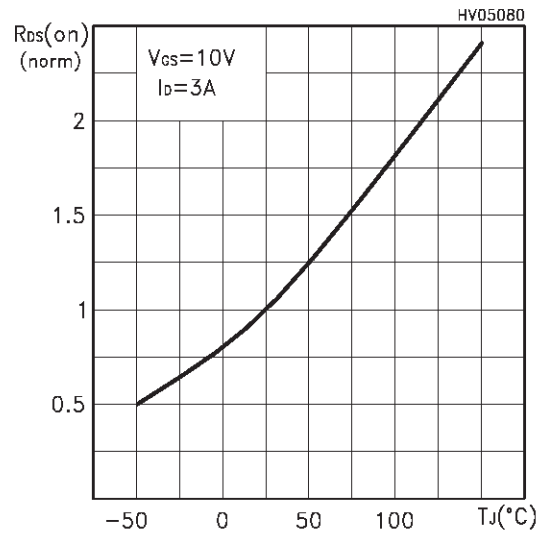

Fig. 1: Unclamped Inductive Load Test Circuit

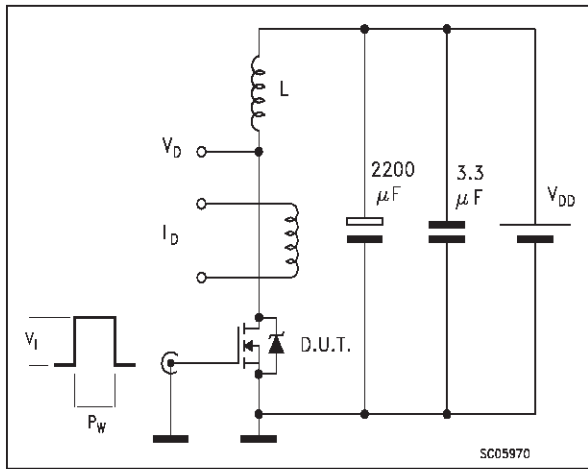

Fig. 2: Unclamped Inductive Waveform

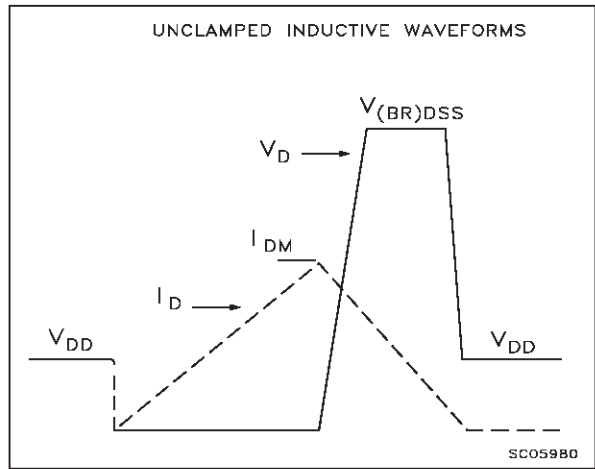

Fig. 3: Switching Times Test Circuit For Resistive Load

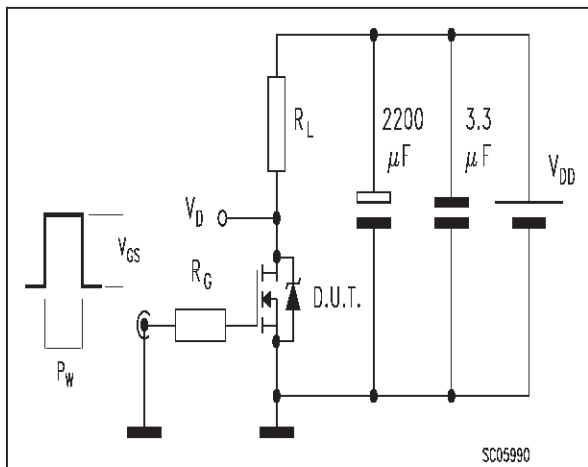

Fig. 4: Gate Charge test Circuit

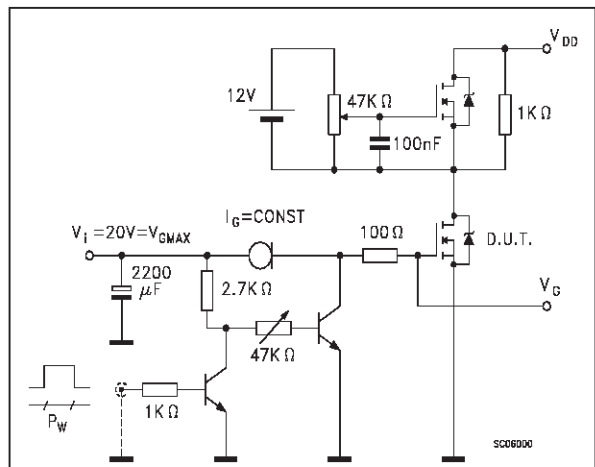
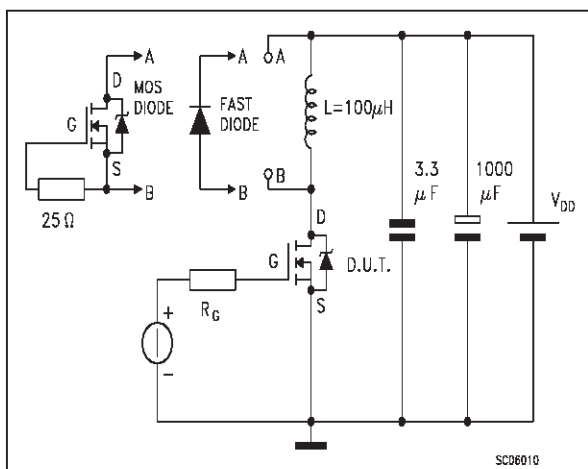

Fig. 5: Test Circuit For Inductive Load Switching And Diode Recovery Times



**TO-220 MECHANICAL DATA**

DIM.	mm			inch		
	MIN.	TYP.	MAX.	MIN.	TYP.	MAX.
A	4.40		4.60	0.173		0.181
C	1.23		1.32	0.048		0.051
D	2.40		2.72	0.094		0.107
D1		1.27			0.050	
E	0.49		0.70	0.019		0.027
F	0.61		0.88	0.024		0.034
F1	1.14		1.70	0.044		0.067
F2	1.14		1.70	0.044		0.067
G	4.95		5.15	0.194		0.203
G1	2.4		2.7	0.094		0.106
H2	10.0		10.40	0.393		0.409
L2		16.4			0.645	
L4	13.0		14.0	0.511		0.551
L5	2.65		2.95	0.104		0.116
L6	15.25		15.75	0.600		0.620
L7	6.2		6.6	0.244		0.260
L9	3.5		3.93	0.137		0.154
DIA.	3.75		3.85	0.147		0.151

