

LOW DROP DUAL POWER OPERATIONAL AMPLIFIERS

- OUTPUT CURRENT TO 1 A
- OPERATES AT LOW VOLTAGES
- SINGLE OR SPLIT SUPPLY
- LARGE COMMON-MODE AND DIFFERENTIAL MODE RANGE
- LOW INPUT OFFSET VOLTAGE
- GROUND COMPATIBLE INPUTS
- LOW SATURATION VOLTAGE
- THERMAL SHUTDOWN
- CLAMP DIODE

DESCRIPTION

The L2720, L2722 and L2724 are monolithic integrated circuits in powerdip, minidip and SIP-9 packages, intended for use as power operational amplifiers in a wide range of applications including servo amplifiers and power supplies.

They are particularly indicated for driving, inductive loads, as motor and finds applications in compact-disc VCR automotive, etc.

The high gain and high output power capability provide superior performance whatever an operational amplifier/power booster combination is required.

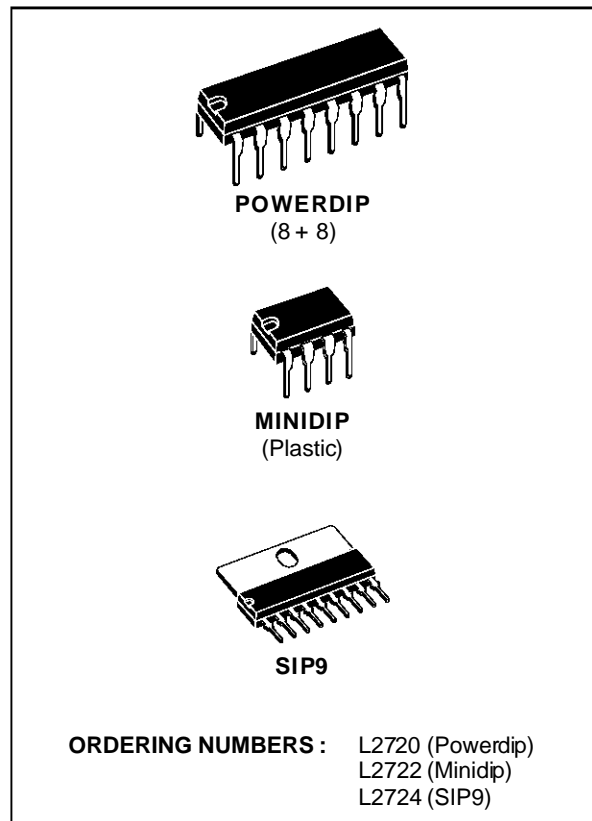

PIN CONNECTIONS (top views)

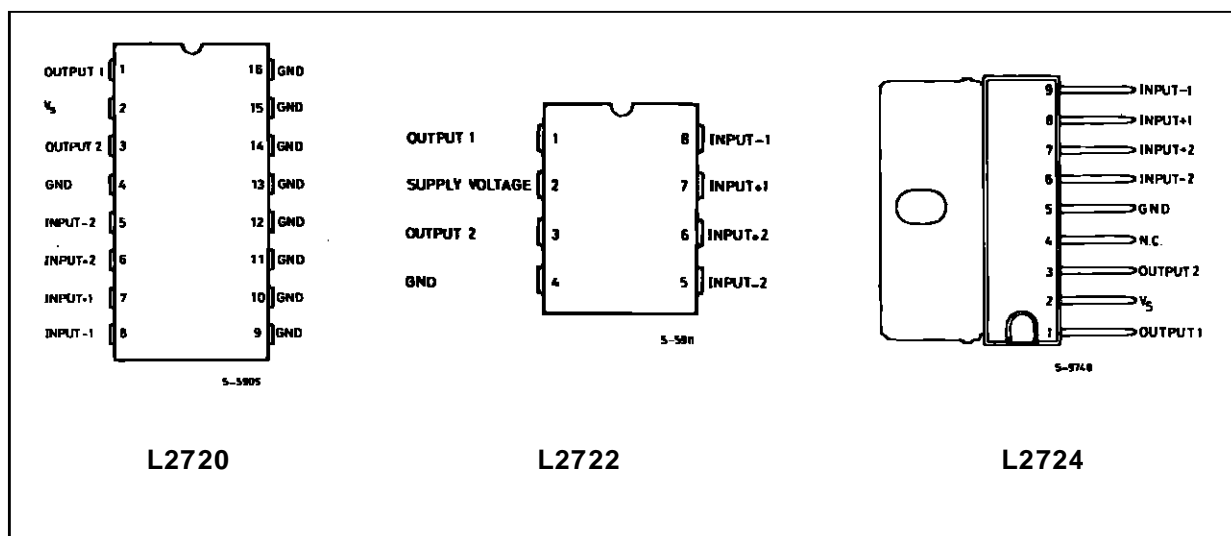

BLOCK DIAGRAM

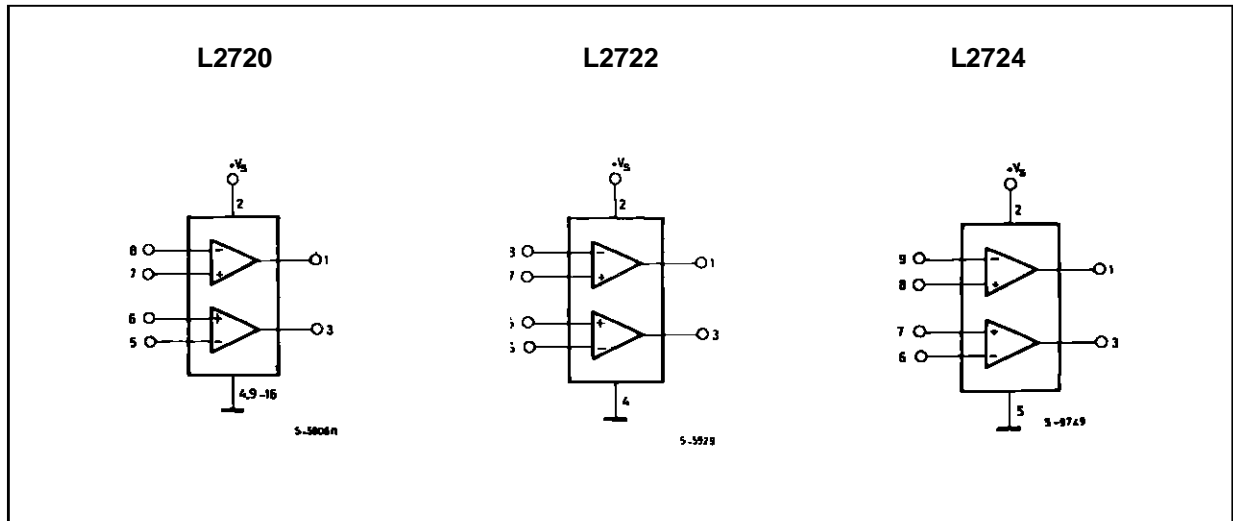

SCHEMATIC DIAGRAM (one section)

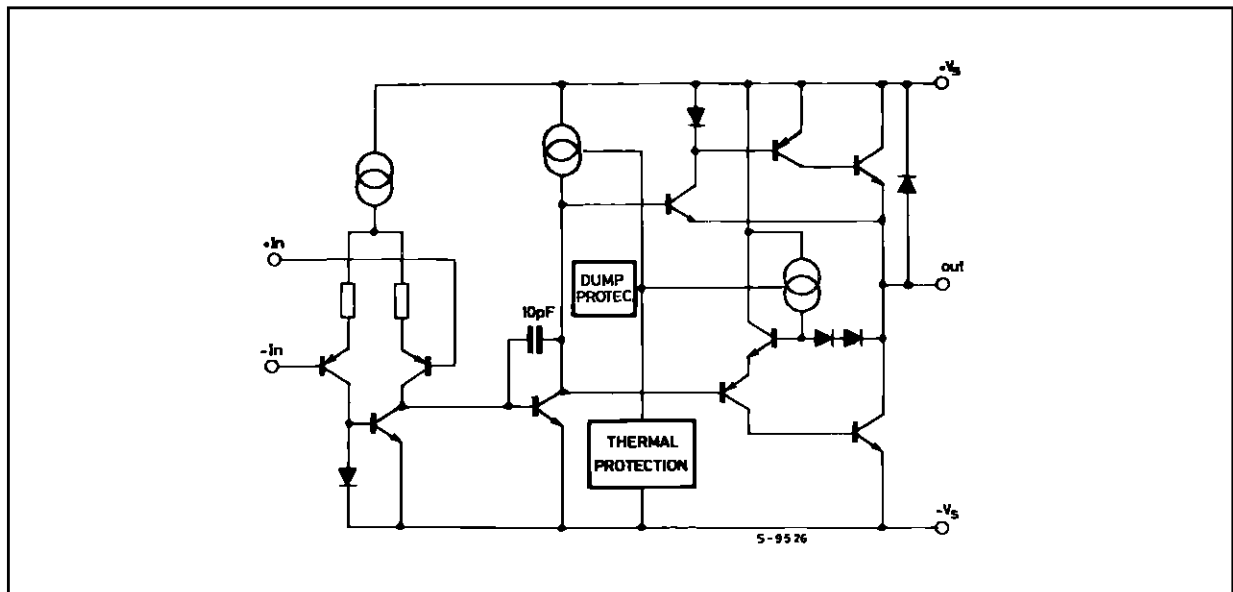

ABSOLUTE MAXIMUM RATINGS

Symbol	Parameter	Value	Unit
V_s	Supply Voltage	28	V
V_s	Peak Supply Voltage (50ms)	50	V
V_i	Input Voltage	V_s	
V_i	Differential Input Voltage	$\pm V_s$	
I_o	DC Output Current	1	A
I_p	Peak Output Current (non repetitive)	1.5	A
P_{tot}	Power Dissipation at $T_{amb} = 80^\circ\text{C}$ (L2720), $T_{amb} = 50^\circ\text{C}$ (L2722) $T_{case} = 75^\circ\text{C}$ (L2720) $T_{case} = 50^\circ\text{C}$ (L2724)	1 5 10	W
T_{stg}, T_j	Storage and Junction Temperature	-40 to 150	$^\circ\text{C}$

THERMAL DATA

			SIP-9	Powerdip	Minidip
R _{th j-case}	Thermal Resistance Junction-case	Max.	10°C/W	15°C/W	70°C/W
R _{th j-amb}	Thermal Resistance Junction-ambient	Max.	70°C/W	70°C/W	100°C/W

ELECTRICAL CHARACTERISTICS

V_s = 24V, T_{amb} = 25°C unless otherwise specified

Symbol	Parameter	Test Conditions	Min.	Typ.	Max.	Unit	
V _s	Single Supply Voltage		4		28	V	
V _s	Split Supply Voltage		± 2		± 14	V	
I _s	Quiescent Drain Current	$V_o = \frac{V_s}{2}$ V _s = 24V V _s = 8V		10 9	15 15	mA	
I _b	Input Bias Current			0.2	1	μA	
V _{os}	Input Offset Voltage				10	mV	
I _{os}	Input Offset Current				100	nA	
SR	Slew Rate			2		V/μs	
B	Gain-bandwidth Product			1.2		MHz	
R _i	Input Resistance		500			kΩ	
G _v	O.L. Voltage Gain	f = 100Hz f = 1kHz	70	80 60		dB	
e _N	Input Noise Voltage	B = 22Hz to 22kHz		10		μV	
I _N	Input Noise Current			200		pA	
CMR	Common Mode Rejection	f = 1kHz	66	84		dB	
SVR	Supply Voltage Rejection	f = 100Hz R _G = 10kΩ V _R = 0.5V	V _s = 24V V _s = ±12V V _s = ±6V	60	70 75 80	dB	
V _{DROP(HIGH)}		V _s = ±2.5V to ±12V	I _p = 100mA I _p = 500mA		0.7 1	1.5	V
V _{DROP(LOW)}		V _s = ±2.5V to ±12V	I _p = 100mA I _p = 500mA		0.3 0.5	1	V
C _s	Channel Separation	f = 1KHz R _L = 10Ω G _v = 30dB	V _s = 24V V _s = 6V		60 60		dB
T _{sd}	Thermal Shutdown Junction Temperature			145		°C	

Figure 1 : Quiescent Current vs. Supply Voltage

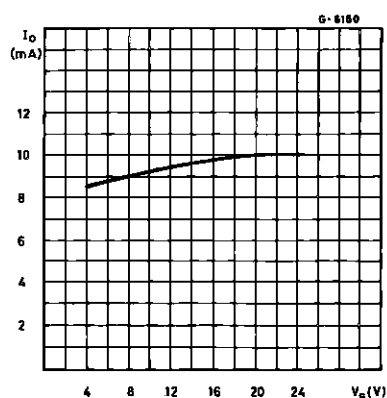

Figure 2 : Open Loop Gain vs. Frequency

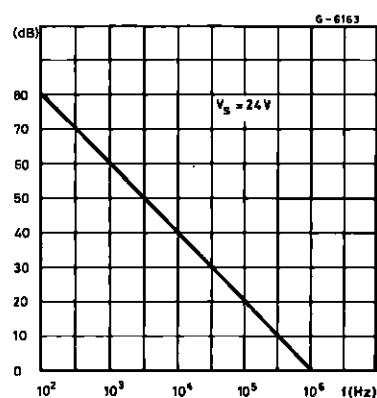

Figure 3 : Common Mode Rejection vs. Frequency

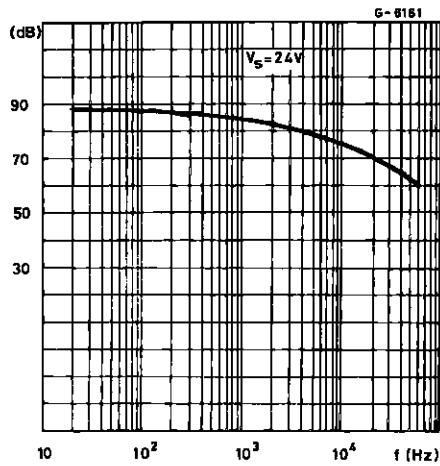

Figure 4 : Output Swing vs. Load Current ($V_S = \pm 5V$).

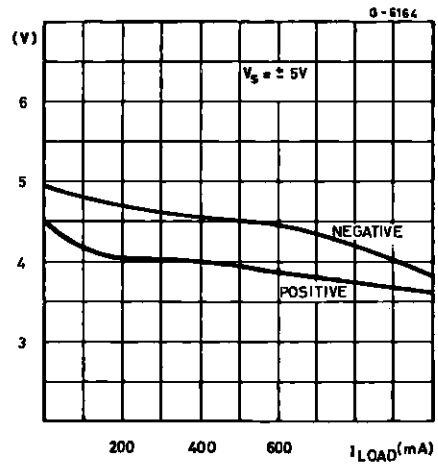

Figure 5 : Output Swing vs. Load Current ($V_S = \pm 12V$).

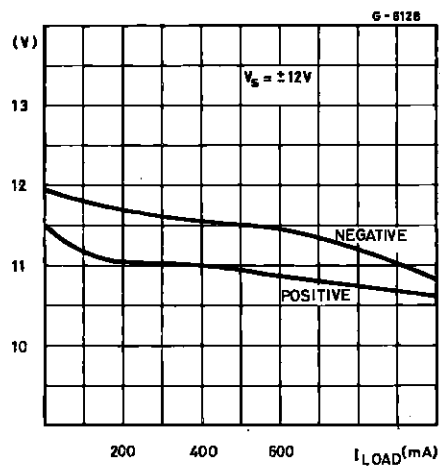

Figure 6 : Supply Voltage rejection vs. Frequency

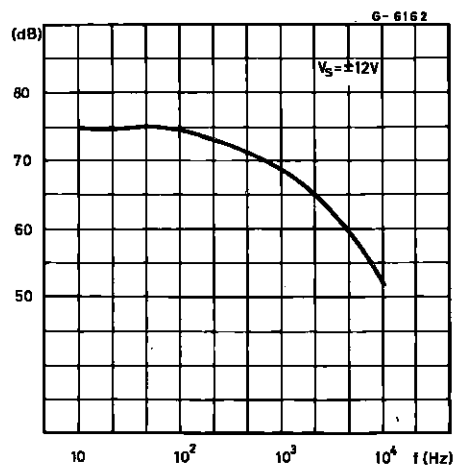
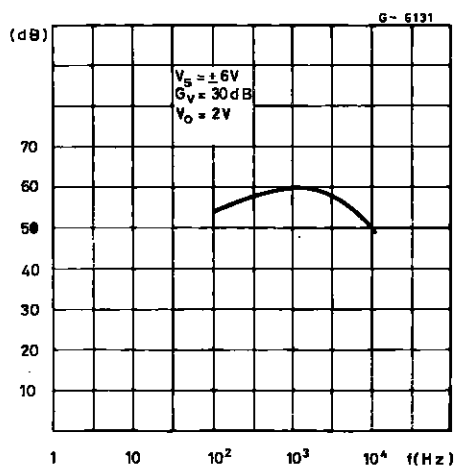

Figure 7 : Channel Separation vs. Frequency



APPLICATION SUGGESTION

In order to avoid possible instability occurring into final stage the usual suggestions for the linear power stages are useful, as for instance :

- layout accuracy ;
- A 100nF capacitor connected between supply pins and ground ;

- boucherot cell (0.1 to 0.2 μ F + 1 Ω series) between outputs and ground or across the load. With single supply operation, a resistor (1k Ω) between the output and supply pin can be necessary for stability.

Figure 8 : Bidirectional DC Motor Control with μ P Compatible Inputs

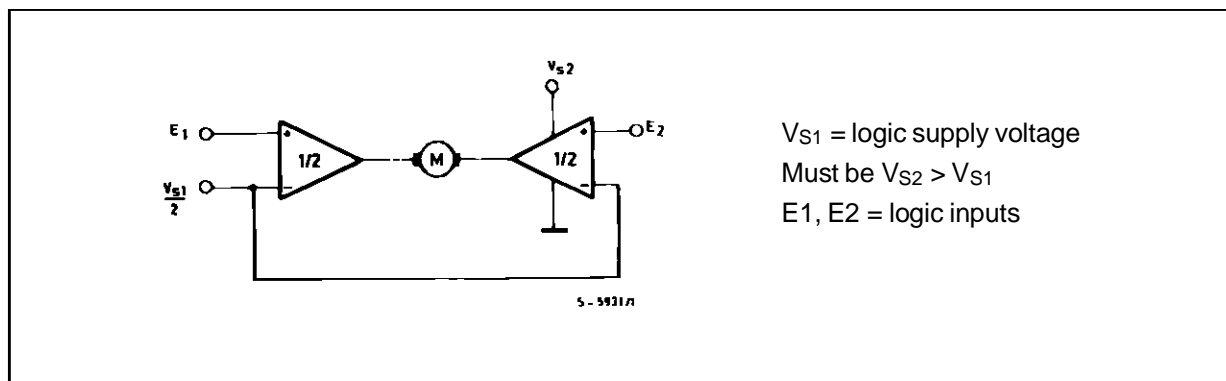

Figure 9 : Servocontrol for Compact-disc

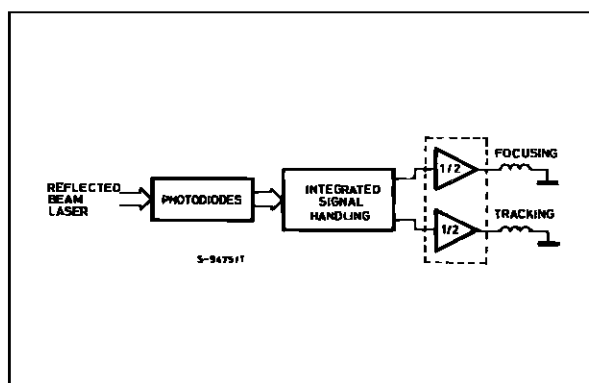

Figure 10 : Capstan Motor Control in Video Recorders

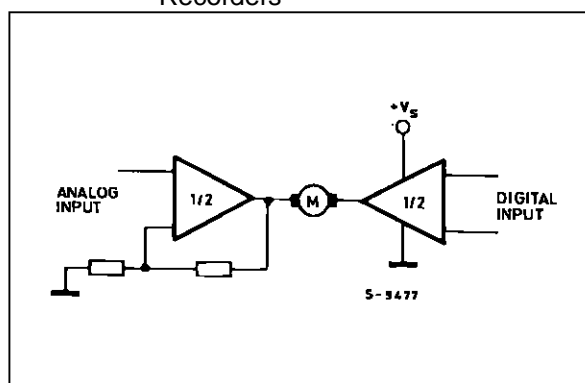

Figure 11 : Motor Current Control Circuit

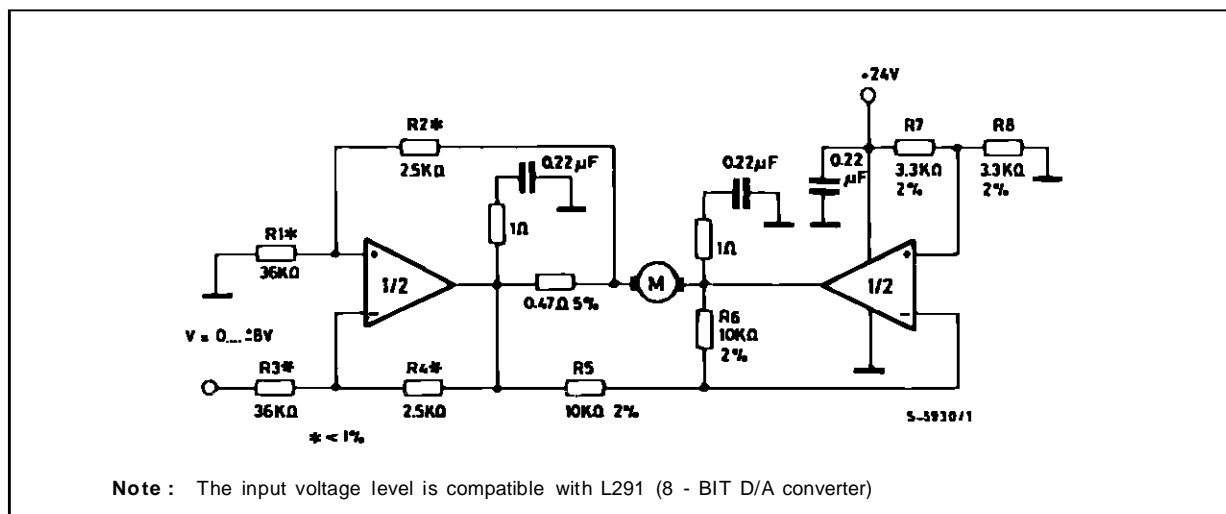

Figure 12 : Bidirectional Speed Control of DC Motors

For circuit stability ensure that $R_x > \frac{2R_3 \cdot R_1}{R_M}$ where R_M = internal resistance of motor.

The voltage available at the terminals of the motor is $V_M = 2 \left(V_i - \frac{V_s}{2} \right) + |R_o| \cdot I_M$ where $|R_o| = \frac{2R_3 \cdot R_1}{R_x}$ and I_M is the motor current.

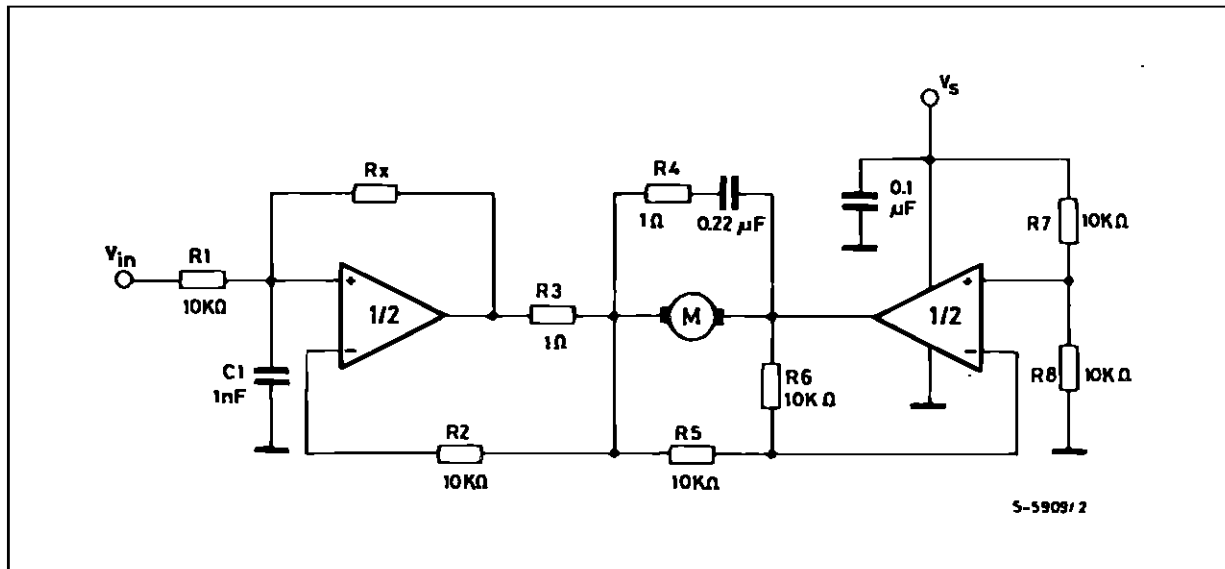
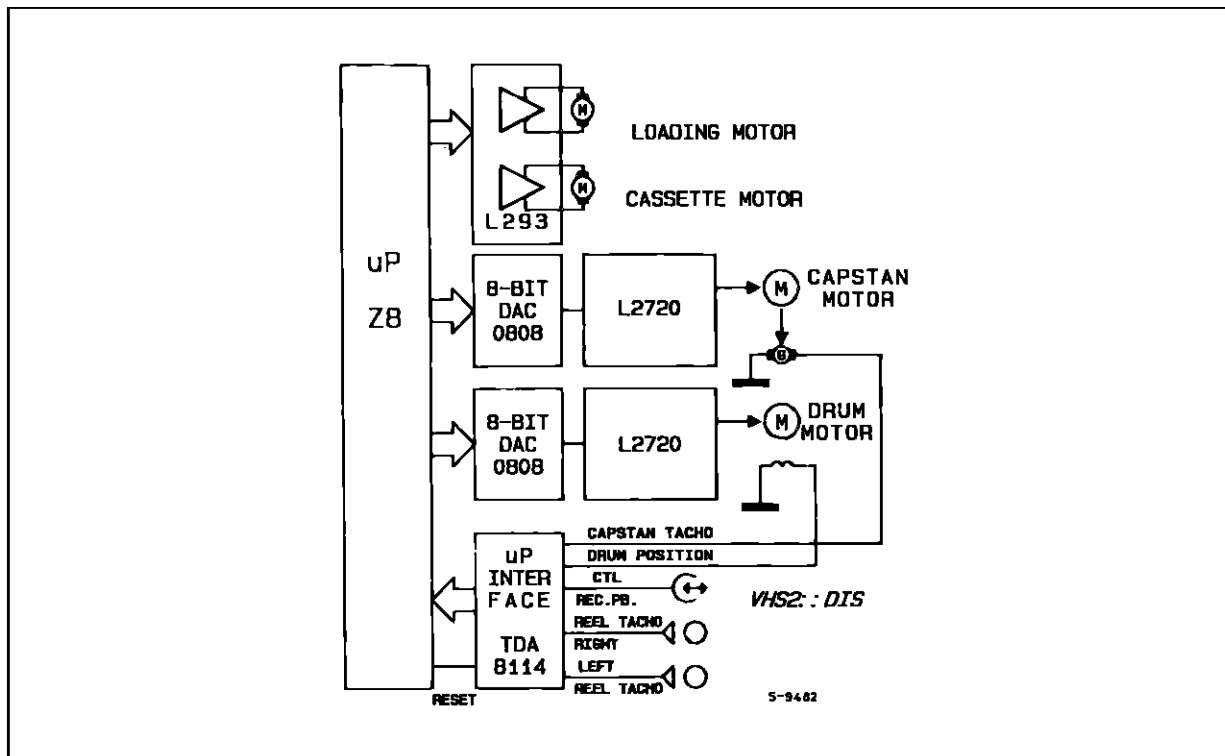
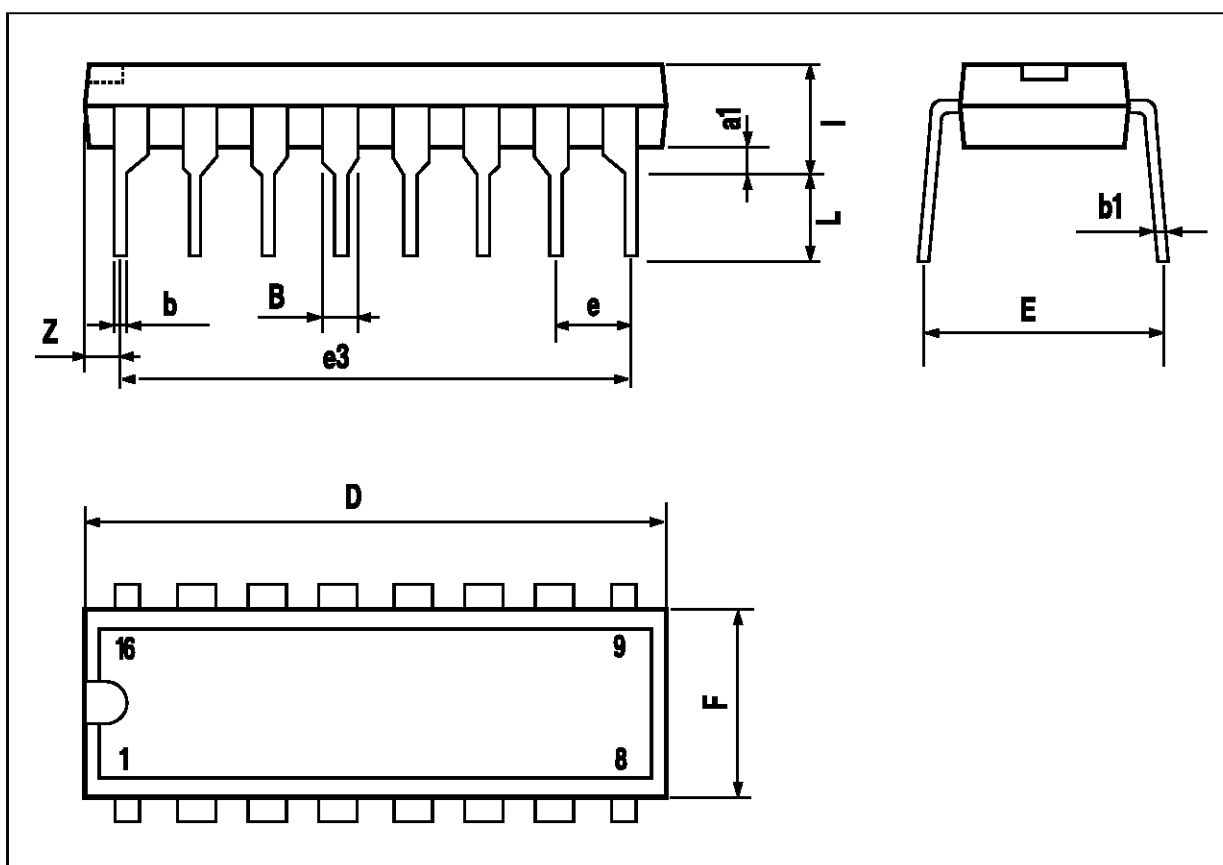

Figure 13 : VHS-VCR Motor Control Circuit



POWERDIP 16 PACKAGE MECHANICAL DATA

DIM.	mm			inch		
	MIN.	TYP.	MAX.	MIN.	TYP.	MAX.
a1	0.51			0.020		
B	0.85		1.40	0.033		0.055
b		0.50			0.020	
b1	0.38		0.50	0.015		0.020
D			20.0			0.787
E		8.80			0.346	
e		2.54			0.100	
e3		17.78			0.700	
F			7.10			0.280
l			5.10			0.201
L		3.30			0.130	
Z			1.27			0.050



MINIDIP PACKAGE MECHANICAL DATA

DIM.	mm			inch		
	MIN.	TYP.	MAX.	MIN.	TYP.	MAX.
A		3.3			0.130	
a1	0.7			0.028		
B	1.39		1.65	0.055		0.065
B1	0.91		1.04	0.036		0.041
b		0.5			0.020	
b1	0.38		0.5	0.015		0.020
D			9.8			0.386
E		8.8			0.346	
e		2.54			0.100	
e3		7.62			0.300	
e4		7.62			0.300	
F			7.1			0.280
l			4.8			0.189
L		3.3			0.130	
Z	0.44		1.6	0.017		0.063

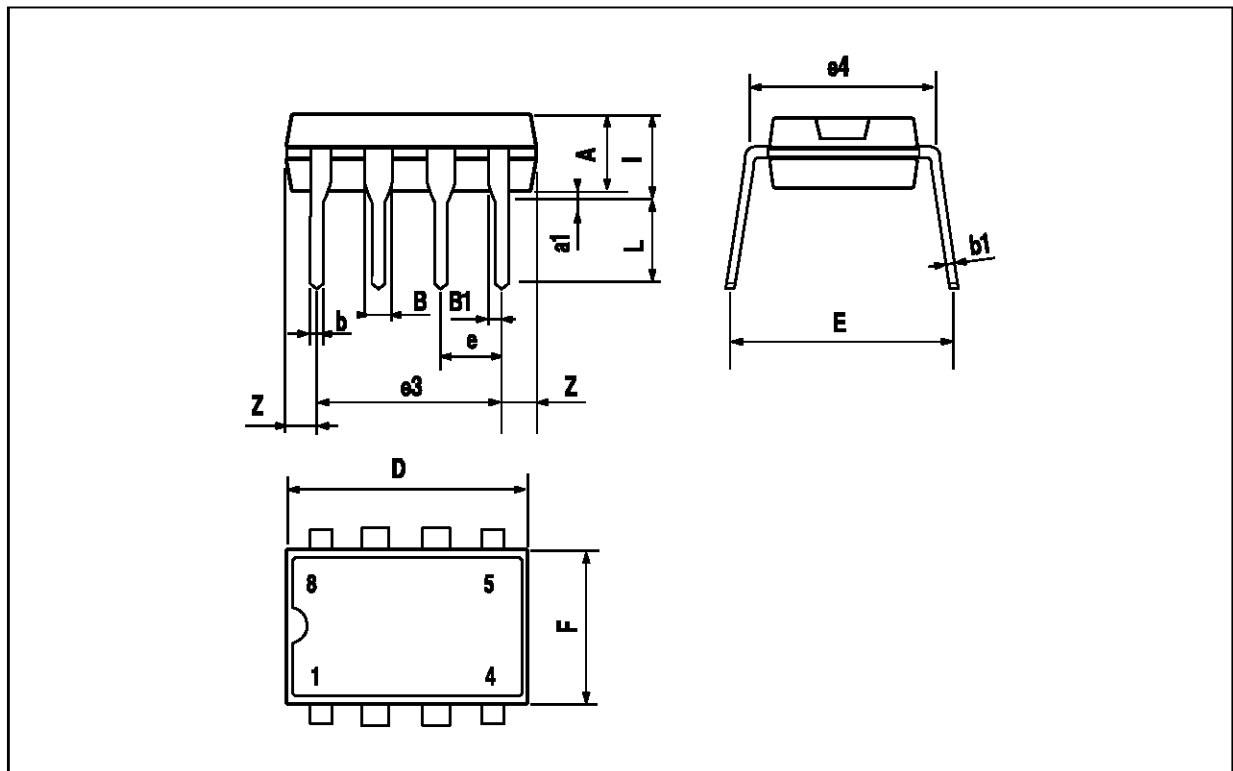

SIP9 PACKAGE MECHANICAL DATA

DIM.	mm			inch		
	MIN.	TYP.	MAX.	MIN.	TYP.	MAX.
A			7.1			0.280
a1	2.7		3	0.106		0.118
B			23			0.90
B3			24.8			0.976
b1		0.5			0.020	
b3	0.85		1.6	0.033		0.063
C		3.3			0.130	
c1		0.43			0.017	
c2		1.32			0.052	
D			21.2			0.835
d1		14.5			0.571	
e		2.54			0.100	
e3		20.32			0.800	
L	3.1			0.122		
L1		3			0.118	
L2		17.6			0.693	
L3			0.25			0.010
L4	17.4		17.85	0.685		0.702
M		3.2			0.126	
N		1			0.039	
P			0.15			0.006

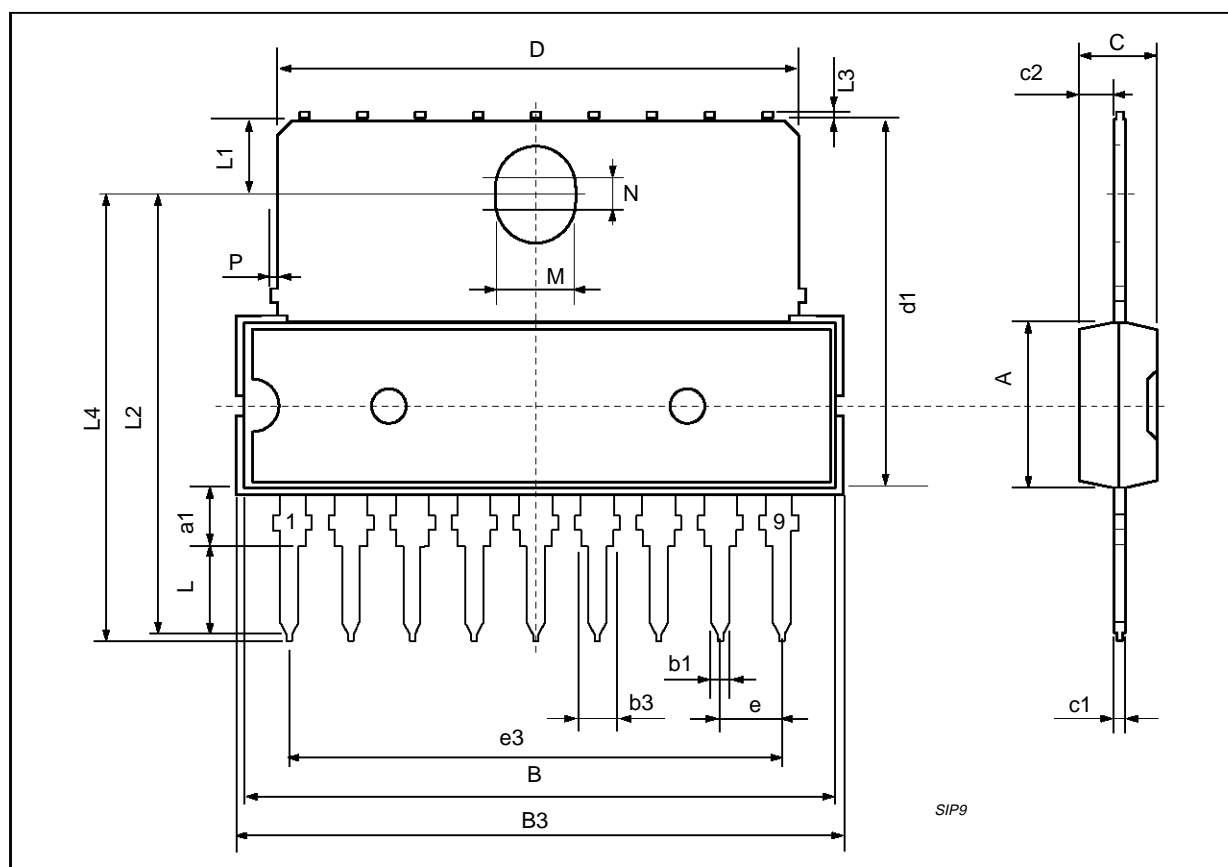

Information furnished is believed to be accurate and reliable. However, SGS-THOMSON Microelectronics assumes no responsibility for the consequences of use of such information nor for any infringement of patents or other rights of third parties which may result from its use. No license is granted by implication or otherwise under any patent or patent rights of SGS-THOMSON Microelectronics. Specification mentioned in this publication are subject to change without notice. This publication supersedes and replaces all information previously supplied. SGS-THOMSON Microelectronics products are not authorized for use as critical components in life support devices or systems without express written approval of SGS-THOMSON Microelectronics.

© 1996 SGS-THOMSON Microelectronics – Printed in Italy – All Rights Reserved

SGS-THOMSON Microelectronics GROUP OF COMPANIES

Australia - Brazil - Canada - China - France - Germany - Hong Kong - Italy - Japan - Korea - Malaysia - Malta - Morocco -
The Netherlands - Singapore - Spain - Sweden - Switzerland - Taiwan - Thailand - United Kingdom - U.S.A.