



M48Z129Y* M48Z129V

5.0V OR 3.3V, 1 Mbit (128 Kb x 8) ZEROPOWER® SRAM

FEATURES SUMMARY

- INTEGRATED, ULTRA LOW POWER SRAM, POWER-FAIL CONTROL CIRCUIT, and BATTERY
- CONVENTIONAL SRAM OPERATION; UNLIMITED WRITE CYCLES
- 10 YEARS OF DATA RETENTION IN THE ABSENCE OF POWER
- MICROPROCESSOR POWER-ON RESET (RESET VALID EVEN DURING BATTERY BACK-UP MODE)
- BATTERY LOW PIN - PROVIDES WARNING OF BATTERY END-OF-LIFE
- AUTOMATIC POWER-FAIL CHIP DESELECT and WRITE PROTECTION
- WRITE PROTECT VOLTAGES (V_{PFD} = Power-fail Deselect Voltage):
 - M48Z129Y: $V_{CC} = 4.5$ to $5.5V$
 $4.2V \leq V_{PFD} \leq 4.5V$
 - M48Z129V: $V_{CC} = 3.0$ to $3.6V$
 $2.7V \leq V_{PFD} \leq 3.0V$
- SELF-CONTAINED BATTERY IN THE CAPHAT™ DIP PACKAGE
- PIN and FUNCTION COMPATIBLE WITH JEDEC STANDARD 128K x 8 SRAMs

Figure 1. 32-pin PMDIP Module

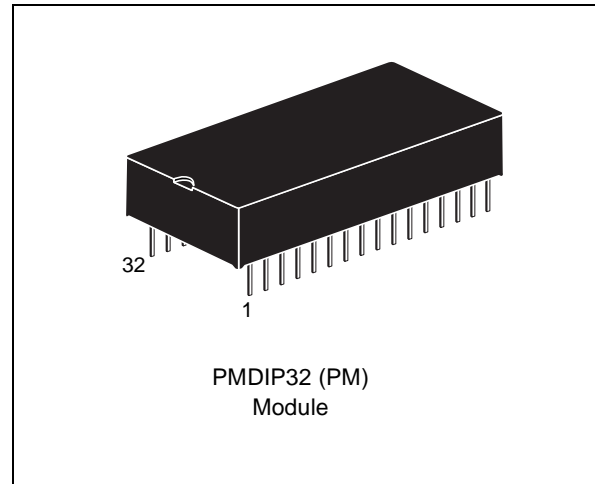

* Contact Local Sales Office

TABLE OF CONTENTS

SUMMARY DESCRIPTION **3**

 Logic Diagram (Figure 2.) 3

 Signal Names (Table 1.) 3

 DIP Connections (Figure 3.) 3

 Block Diagram (Figure 4.) 4

MAXIMUM RATING **4**

 Absolute Maximum Ratings (Table 2.) 4

DC AND AC PARAMETERS **5**

 Operating and AC Measurement Conditions (Table 3.) 5

 AC Testing Load Circuit (Figure 5.) 5

 Capacitance (Table 4.) 5

 DC Characteristics (Table 5.) 6

OPERATION MODES **6**

 Operating Modes (Table 6.) 6

 READ Mode 7

 Address Controlled, READ Mode AC Waveforms (Figure 6.) 7

 Chip Enable or Output Enable Controlled, READ Mode AC Waveforms (Figure 7.) 7

 READ Mode AC Characteristics (Table 7.) 8

 WRITE Mode 9

 WRITE Enable Controlled, WRITE Mode AC Waveform (Figure 8.) 9

 Chip Enable Controlled, WRITE Mode AC Waveforms (Figure 9.) 9

 WRITE Mode AC Characteristics (Table 8.) 10

 Data Retention Mode 11

 Power Down/Up Mode AC Waveforms (Figure 10.) 11

 Power Down/Up AC Characteristics (Table 9.) 12

 Power Down/Up Trip Points DC Characteristics (Table 10.) 12

 V_{CC} Noise And Negative Going Transients 13

 Supply Voltage Protection (Figure 11.) 13

PART NUMBERING **14**

PACKAGE MECHANICAL INFORMATION **15**

REVISION HISTORY **16**

SUMMARY DESCRIPTION

The M48Z129Y/V ZEROPOWER® SRAM is a 1,048,576 bit non-volatile static RAM organized as 131,072 words by 8 bits. The device combines an internal lithium battery, a CMOS SRAM and a control circuit in a plastic 32-pin DIP Module. The

M48Z129Y/V directly replaces industry standard 128K x 8 SRAM. It also provides the non-volatility of FLASH without any requirement for special WRITE timing or limitations on the number of WRITES that can be performed.

Figure 2. Logic Diagram

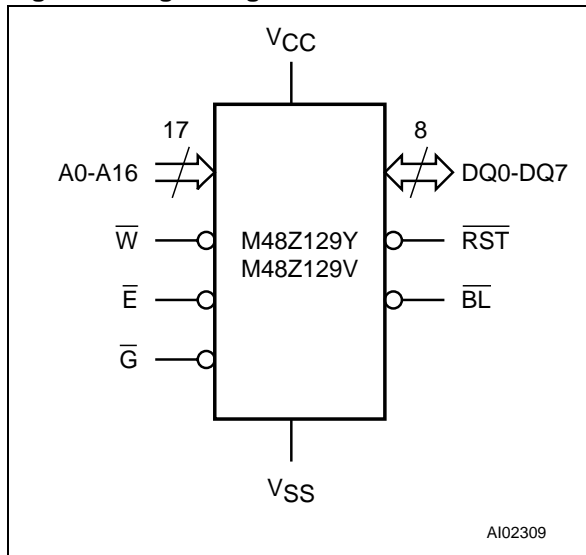

Table 1. Signal Names

A0-A16	Address Inputs
DQ0-DQ7	Data Inputs / Outputs
\bar{E}	Chip Enable
\bar{G}	Output Enable
\bar{W}	WRITE Enable
\bar{RST}	Reset Output (Open Drain)
\bar{BL}	Battery Low Output (Open Drain)
VCC	Supply Voltage
VSS	Ground

Figure 3. DIP Connections

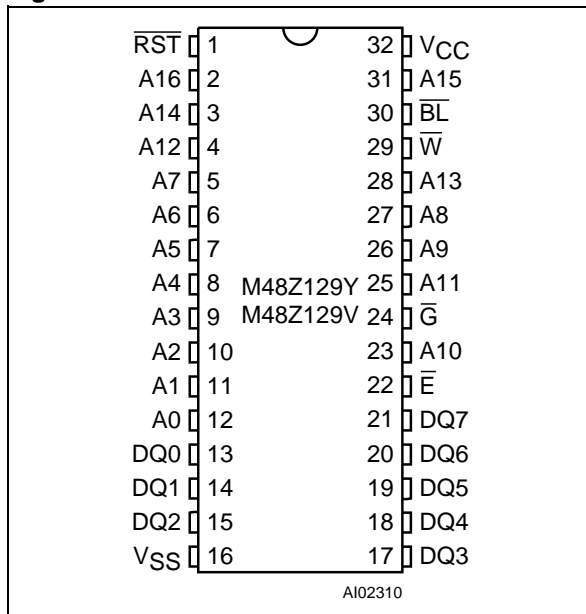
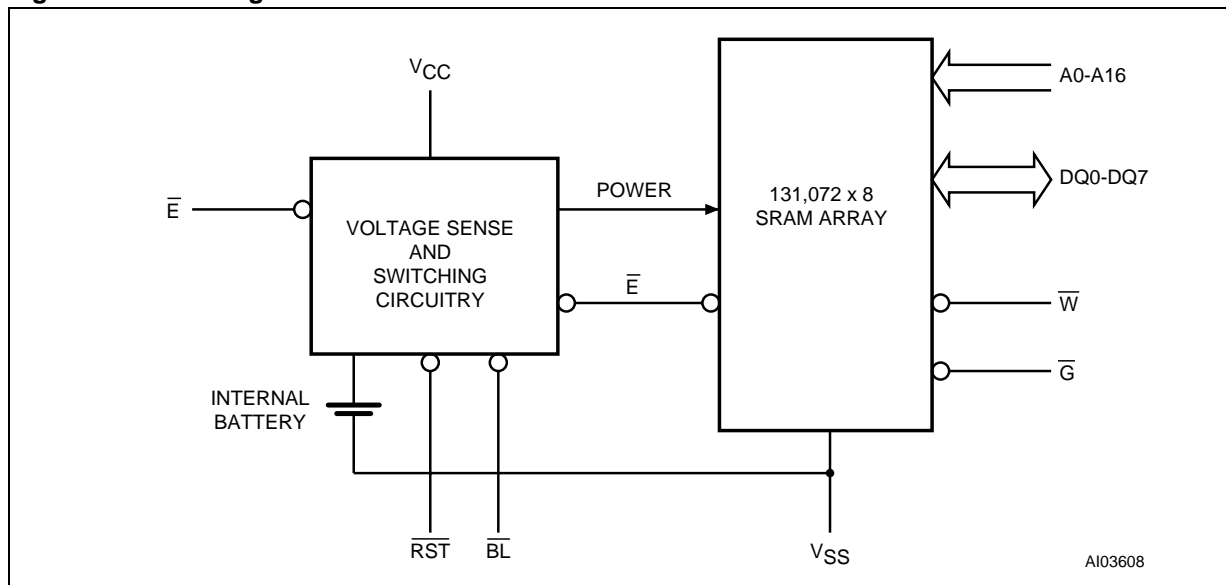

Figure 4. Block Diagram



MAXIMUM RATING

Stressing the device above the rating listed in the “Absolute Maximum Ratings” table may cause permanent damage to the device. These are stress ratings only and operation of the device at these or any other conditions above those indicated in the Operating sections of this specification is

not implied. Exposure to Absolute Maximum Rating conditions for extended periods may affect device reliability. Refer also to the STMicroelectronics SURE Program and other relevant quality documents.

Table 2. Absolute Maximum Ratings

Symbol	Parameter	Value	Unit
T _A	Ambient Operating Temperature	0 to 70	°C
T _{STG}	Storage Temperature (V _{CC} Off, Oscillator Off)	-40 to 85	°C
T _{SLD} ⁽¹⁾	Lead Solder Temperature for 10 seconds	260	°C
V _{IO}	Input or Output Voltages	-0.3 to 7	V
V _{CC}	Supply Voltage	-0.3 to 7	V
I _O	Output Current	20	mA
P _D	Power Dissipation	1	W

Note: 1. Soldering temperature not to exceed 260°C for 10 seconds (total thermal budget not to exceed 150°C for longer than 30 seconds).

CAUTION: Negative undershoots below -0.3V are not allowed on any pin while in the Battery Back-up mode.

DC AND AC PARAMETERS

This section summarizes the operating and measurement conditions, as well as the DC and AC characteristics of the device. The parameters in the following DC and AC Characteristic tables are derived from tests performed under the Measure-

ment Conditions listed in the relevant tables. Designers should check that the operating conditions in their projects match the measurement conditions when using the quoted parameters.

Table 3. Operating and AC Measurement Conditions

Parameter	M48Z129Y	M48Z129V	Unit
Supply Voltage (V _{CC})	4.5 to 5.5	3.0 to 3.6	V
Ambient Operating Temperature (T _A)	0 to 70	0 to 70	°C
Load Capacitance (C _L)	100	50	pF
Input Rise and Fall Times	≤ 5	≤ 5	ns
Input Pulse Voltages	0 to 3	0 to 3	V
Input and Output Timing Ref. Voltages	1.5	1.5	V

Note: Output Hi-Z is defined as the point where data is no longer driven.

Figure 5. AC Testing Load Circuit

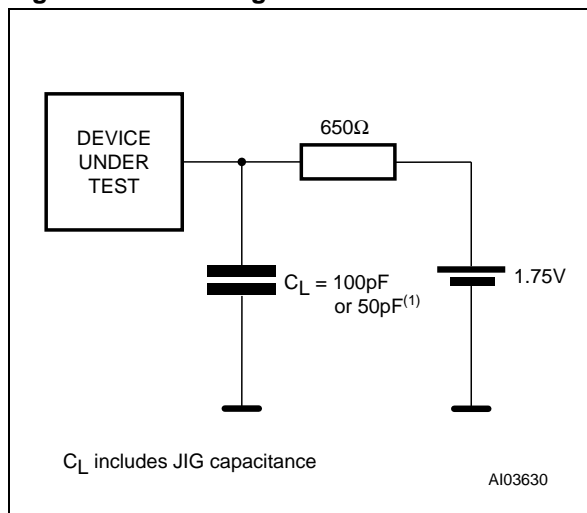

Note: 1. 50pF for M48Z129V (3.3V).

Table 4. Capacitance

Symbol	Parameter ^(1,2)	Min	Max	Unit
C _{IN}	Input Capacitance		10	pF
C _{IO} ⁽³⁾	Input / Output Capacitance		10	pF

Note: 1. Effective capacitance measured with power supply at 5V; sampled only, not 100% tested.
 2. At 25°C, f = 1MHz.
 3. Outputs deselected.

Table 5. DC Characteristics

Sym	Parameter	Test Condition ⁽¹⁾	M48Z129Y		M48Z129V		Unit
			-70		-85		
			Min	Max	Min	Max	
I _{LI}	Input Leakage Current	0V ≤ V _{IN} ≤ V _{CC}		±1		±1	µA
I _{LO} ⁽²⁾	Output Leakage Current	0V ≤ V _{OUT} ≤ V _{CC}		±1		±1	µA
I _{CC}	Supply Current	Outputs open		95		50	mA
I _{CC1}	Supply Current (Standby) TTL	$\bar{E} = V_{IH}$		7		4	mA
I _{CC2}	Supply Current (Standby) CMOS	$\bar{E} = V_{CC} - 0.2V$		4		3	mA
V _{IL}	Input Low Voltage		-0.3	0.8	-0.3	0.6	V
V _{IH}	Input High Voltage		2.2	V _{CC} + 0.3	2.2	V _{CC} + 0.3	V
V _{OL}	Output Low Voltage	I _{OL} = 2.1mA		0.4		0.4	V
V _{OH}	Output High Voltage	I _{OH} = -1mA	2.4		2.2		V

Note: 1. Valid for Ambient Operating Temperature: T_A = 0 to 70°C; V_{CC} = 4.5 to 5.5V or 3.0 to 3.6V (except where noted).
 2. Outputs deselected.

OPERATION MODES

The M48Z129Y/V also has its own Power-Fail Detect circuit. This control circuitry constantly monitors the supply voltage for an out of tolerance condition. When V_{CC} is out of tolerance, the circuit write protects the SRAM, providing data security in

the midst of unpredictable system operation. As V_{CC} falls, the control circuitry automatically switches to the battery, maintaining data until valid power is restored.

Table 6. Operating Modes

Mode	V _{CC}	\bar{E}	\bar{G}	\bar{W}	DQ0-DQ7	Power
Deselect	4.5 to 5.5V or 3.0 to 3.6V	V _{IH}	X	X	High Z	Standby
WRITE		V _{IL}	X	V _{IL}	D _{IN}	Active
READ		V _{IL}	V _{IL}	V _{IH}	D _{OUT}	Active
READ		V _{IL}	V _{IH}	V _{IH}	High Z	Active
Deselect	V _{SO} to V _{PFD} (min) ⁽¹⁾	X	X	X	High Z	CMOS Standby
Deselect	≤ V _{SO} ⁽¹⁾	X	X	X	High Z	Battery Back-up Mode

Note: X = V_{IH} or V_{IL}; V_{SO} = Battery Back-up Switchover Voltage.
 1. See Table 10, page 12 for details.

READ Mode

The M48Z129Y/V is in the READ Mode whenever \overline{W} (WRITE Enable) is high and \overline{E} (Chip Enable) is low. The unique address specified by the 17 address inputs defines which one of the 131,072 bytes of data is to be accessed. Valid data will be available at the Data I/O pins within t_{AVQV} (Address Access Time) after the last address input signal is stable, providing the \overline{E} and \overline{G} access times are also satisfied. If the \overline{E} and \overline{G} access times are not met, valid data will be available after

the latter of the Chip Enable Access Times (t_{ELQV}) or Output Enable Access Time (t_{GLQV}).

The state of the eight three-state Data I/O signals is controlled by \overline{E} and \overline{G} . If the outputs are activated before t_{AVQV} , the data lines will be driven to an indeterminate state until t_{AVQV} . If the Address Inputs are changed while \overline{E} and \overline{G} remain active, output data will remain valid for t_{AXQX} (Output Data Hold Time) but will go indeterminate until the next Address Access.

Figure 6. Address Controlled, READ Mode AC Waveforms

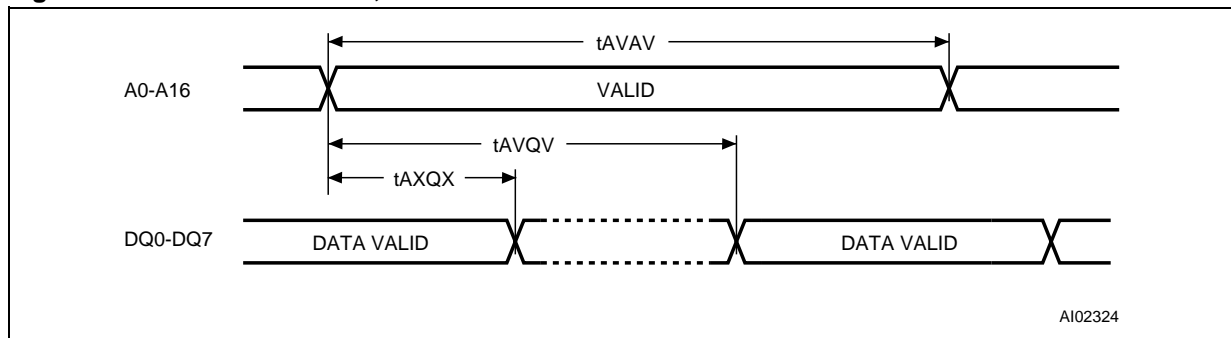

Note: Chip Enable (\overline{E}) and Output Enable (\overline{G}) = Low, WRITE Enable (\overline{W}) = High.

Figure 7. Chip Enable or Output Enable Controlled, READ Mode AC Waveforms

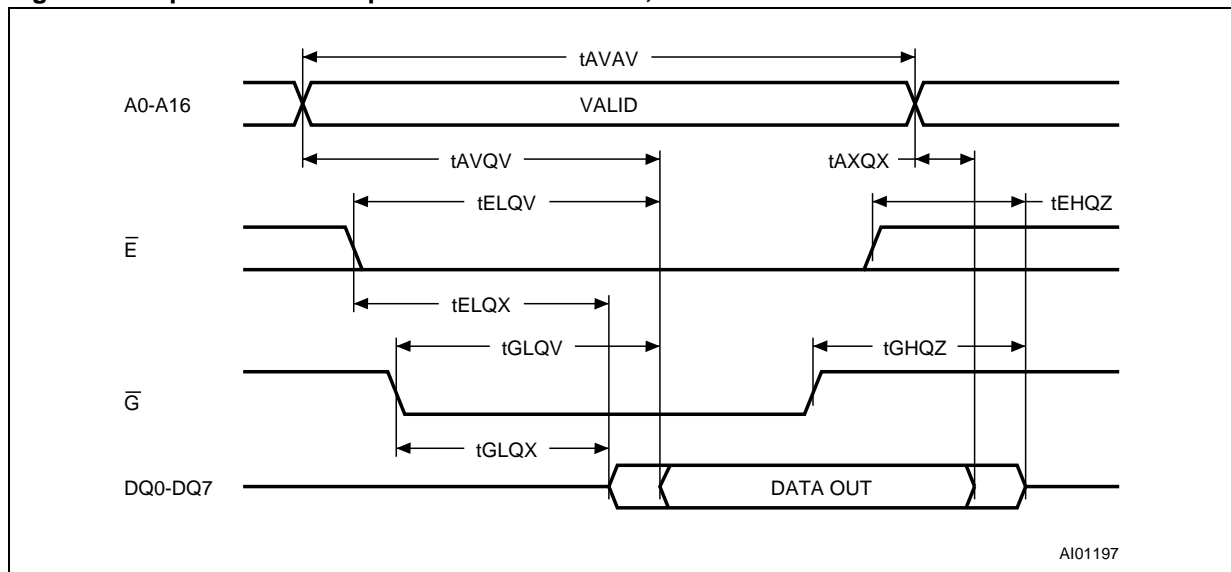

Table 7. READ Mode AC Characteristics

Symbol	Parameter ⁽¹⁾	M48Z129Y		M48Z129V		Unit
		-70		-85		
		Min	Max	Min	Max	
t _{AVAV}	READ Cycle Time	70		85		ns
t _{AVQV}	Address Valid to Output Valid		70		85	ns
t _{ELQV}	Chip Enable Low to Output Valid		70		85	ns
t _{GLQV}	Output Enable Low to Output Valid		35		45	ns
t _{ELQX} ⁽²⁾	Chip Enable Low to Output Transition	5		5		ns
t _{GLQX} ⁽²⁾	Output Enable Low to Output Transition	3		5		ns
t _{EHQZ} ⁽²⁾	Chip Enable High to Output Hi-Z		30		40	ns
t _{GHQZ} ⁽²⁾	Output Enable High to Output Hi-Z		20		25	ns
t _{AXQX}	Address Transition to Output Transition	5		5		ns

Note: 1. Valid for Ambient Operating Temperature: T_A = 0 to 70°C; V_{CC} = 4.5 to 5.5V or 3.0 to 3.6V (except where noted).

2. C_L = 5pF (see Figure 5, page 5).

WRITE Mode

The M48Z129Y/V is in the WRITE Mode whenever \overline{W} (WRITE Enable) and \overline{E} (Chip Enable) are active. The start of a WRITE is referenced from the latter occurring falling edge of \overline{W} or \overline{E} . A WRITE is terminated by the earlier rising edge of \overline{W} or \overline{E} . The addresses must be held valid throughout the cycle. \overline{E} or \overline{W} must return high for a minimum of t_{EHAX} from Chip Enable or t_{WHAX} from WRITE En-

able prior to the initiation of another READ or WRITE cycle. Data-in must be valid t_{DVWH} prior to the end of WRITE and remain valid for t_{WHDX} afterward. \overline{G} should be kept high during WRITE cycles to avoid bus contention; although, if the output bus has been activated by a low on \overline{E} and \overline{G} a low on \overline{W} will disable the outputs t_{WLQZ} after \overline{W} falls.

Figure 8. WRITE Enable Controlled, WRITE Mode AC Waveform

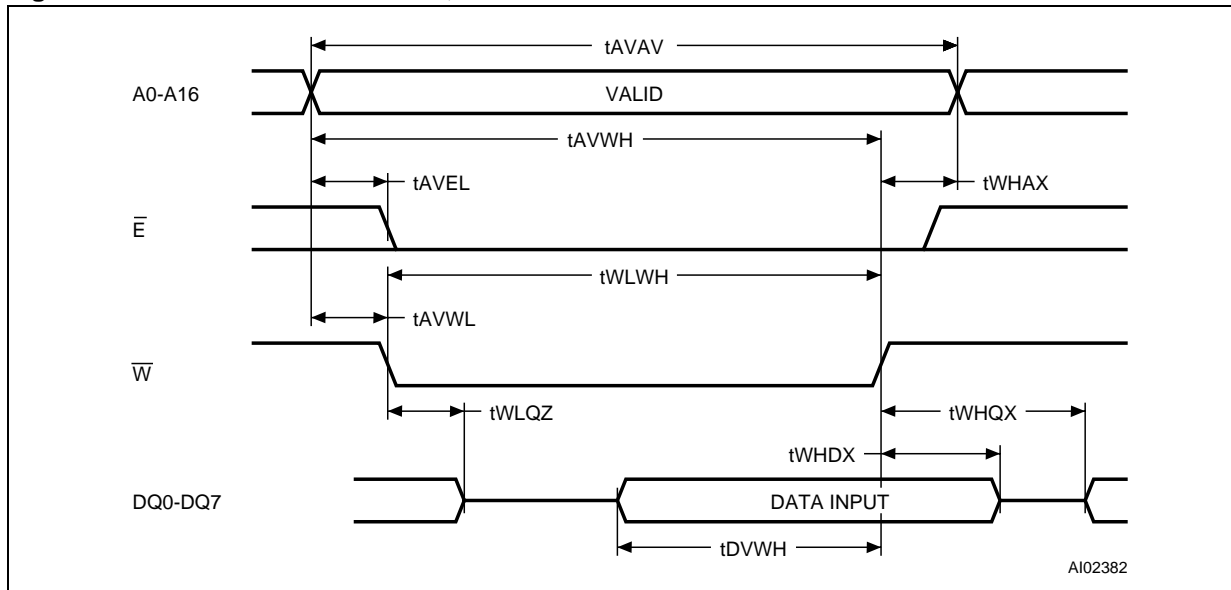

Figure 9. Chip Enable Controlled, WRITE Mode AC Waveforms

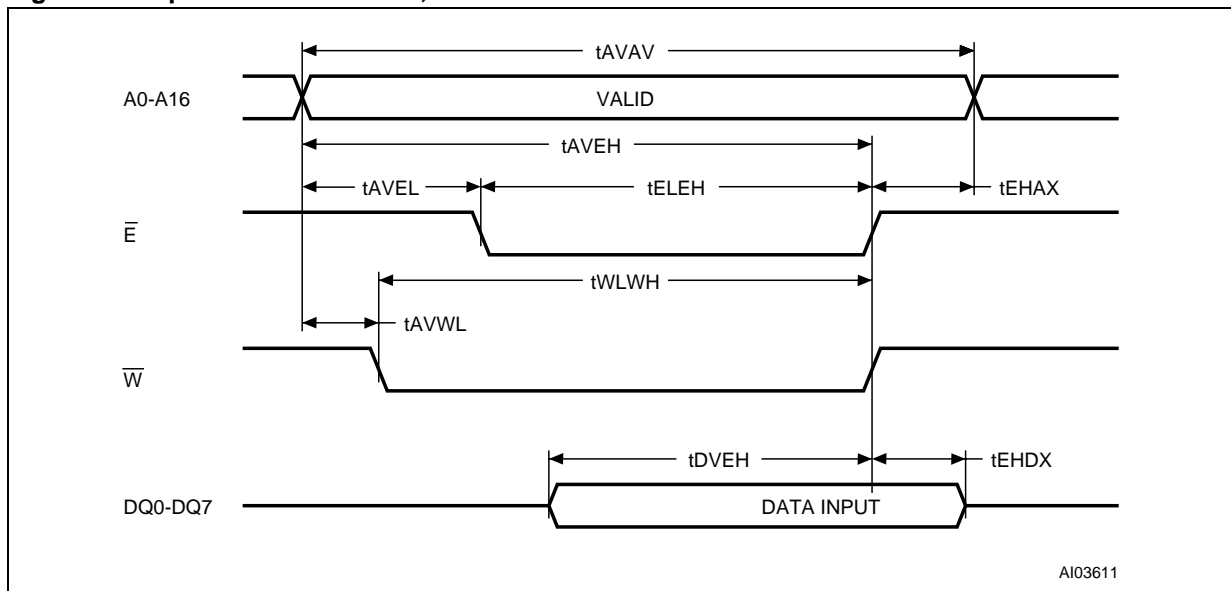

Table 8. WRITE Mode AC Characteristics

Symbol	Parameter ⁽¹⁾	M48Z129Y		M48Z129V		Unit
		-70		-85		
		Min	Max	Min	Max	
t _{AVAV}	WRITE Cycle Time	70		85		ns
t _{AVWL}	Address Valid to WRITE Enable Low	0		0		ns
t _{AVEL}	Address Valid to Chip Enable Low	0		0		ns
t _{WLWH}	WRITE Enable Pulse Width	55		65		ns
t _{LEH}	Chip Enable Low to Chip Enable High	55		75		ns
t _{WHAX}	WRITE Enable High to Address Transition	5		5		ns
t _{EHAX}	Chip Enable High to Address Transition	15		15		ns
t _{DVWH}	Input Valid to WRITE Enable High	30		35		ns
t _{DVEH}	Input Valid to Chip Enable High	30		35		ns
t _{WHDX}	WRITE Enable High to Input Transition	0		0		ns
t _{EHDX}	Chip Enable High to Input Transition	10		15		ns
t _{WLQZ} ^(2,3)	WRITE Enable Low to Output Hi-Z		25		30	ns
t _{AVWH}	Address Valid to WRITE Enable High	65		75		ns
t _{AVEH}	Address Valid to Chip Enable High	65		75		ns
t _{WHQX} ^(2,3)	WRITE Enable High to Output Transition	5		5		ns

Note: 1. Valid for Ambient Operating Temperature: T_A = 0 to 70°C; V_{CC} = 4.5 to 5.5V or 3.0 to 3.6V (except where noted).

2. C_L = 5pF (see Figure 5, page 5).

3. If \overline{E} goes low simultaneously with \overline{W} going low, the outputs remain in the high impedance state.

Data Retention Mode

With valid V_{CC} applied, the M48Z129Y/V operates as a conventional BYTEWIDE™ static RAM. Should the supply voltage decay, the RAM will automatically deselect, write protecting itself when V_{CC} falls between $V_{PFD} (max)$, $V_{PFD} (min)$ window. All outputs become high impedance and all inputs are treated as “Don’t care”.

Note: A power failure during a WRITE cycle may corrupt data at the current addressed location, but does not jeopardize the rest of the RAM’s content. At voltages below $V_{PFD}(min)$, the memory will be in a write protected state, provided the V_{CC} fall time is not less than t_F . The M48Z129Y/V may respond to transient noise spikes on V_{CC} that cross into the deselect window during the time the de-

vice is sampling V_{CC} . Therefore, decoupling of the power supply lines is recommended.

When V_{CC} drops below V_{SO} , the control circuit switches power to the internal battery, preserving data. The internal energy source will maintain data in the M48Z129Y/V for an accumulated period of at least 10 years at room temperature. As system power rises above V_{SO} , the battery is disconnected, and the power supply is switched to external V_{CC} . Deselect continues for t_{REC} after V_{CC} reaches $V_{PFD}(max)$.

For more information on Battery Storage Life refer to the Application Note AN1012.

Figure 10. Power Down/Up Mode AC Waveforms

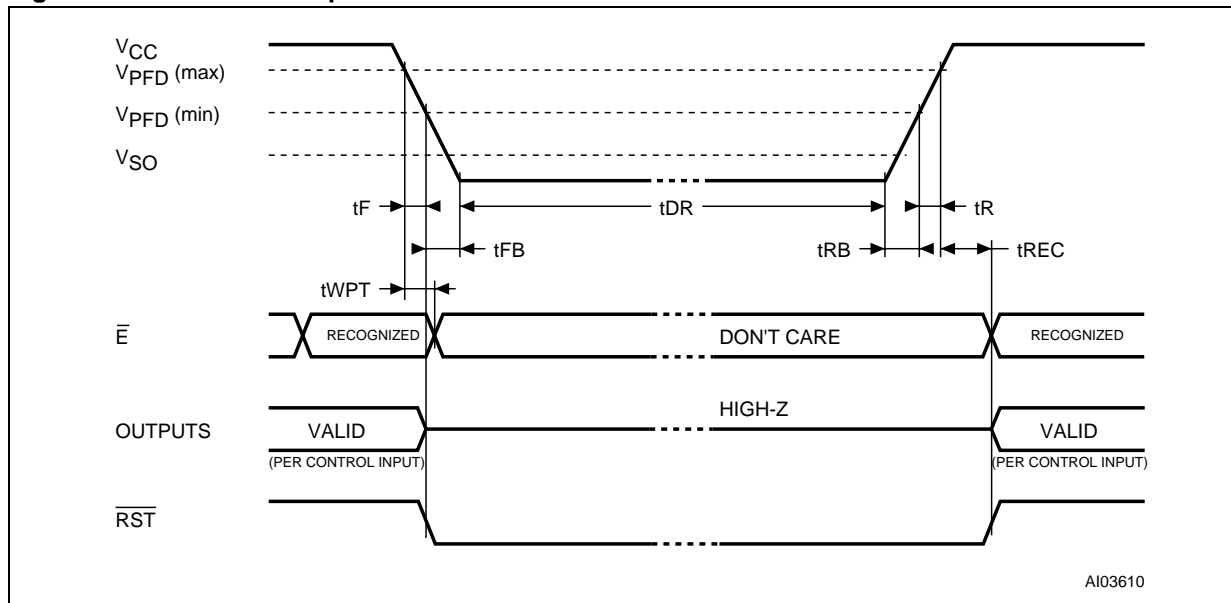

M48Z129Y*, M48Z129V

Table 9. Power Down/Up AC Characteristics

Symbol	Parameter ⁽¹⁾	Min	Max	Unit	
$t_F^{(2)}$	$V_{PFD}(\text{max})$ to $V_{PFD}(\text{min})$ V_{CC} Fall Time	300		μs	
$t_{FB}^{(3)}$	$V_{PFD}(\text{min})$ to V_{SS} V_{CC} Fall Time	M48Z129Y	10	μs	
		M48Z129V	150		
t_R	$V_{PFD}(\text{min})$ to $V_{PFD}(\text{max})$ V_{CC} Rise Time	10		μs	
t_{RB}	V_{SS} to $V_{PFD}(\text{min})$ V_{CC} Rise Time	1		μs	
t_{WPT}	Write Protect Time	M48Z129Y	40	150	μs
		M48Z129V	40	250	
t_{REC}	$V_{PFD}(\text{max})$ to $\overline{\text{RST}}$ High	40	200	ms	

Note: 1. Valid for Ambient Operating Temperature: $T_A = 0$ to 70°C ; $V_{CC} = 4.5$ to 5.5V or 3.0 to 3.6V (except where noted).
 2. $V_{PFD}(\text{max})$ to $V_{PFD}(\text{min})$ fall time of less than t_F may result in deselection/write protection not occurring until $200\mu\text{s}$ after V_{CC} passes $V_{PFD}(\text{min})$.
 3. $V_{PFD}(\text{min})$ to V_{SS} fall time of less than t_{FB} may cause corruption of RAM data.

Table 10. Power Down/Up Trip Points DC Characteristics

Symbol	Parameter ^(1,2)	Min	Typ	Max	Unit	
V_{PFD}	Power-fail Deselect Voltage	M48Z129Y	4.2	4.35	4.5	V
		M48Z129V	2.7	2.9	3.0	V
V_{SO}	Battery Back-up Switchover Voltage	M48Z129Y		3.0		V
		M48Z129V		2.45		V
$t_{DR}^{(3)}$	Expected Data Retention Time	10			YEARS	

Note: 1. All voltages referenced to V_{SS} .
 2. Valid for Ambient Operating Temperature: $T_A = 0$ to 70°C ; $V_{CC} = 4.5$ to 5.5V or 3.0 to 3.6V (except where noted).
 3. At 25°C

V_{CC} Noise And Negative Going Transients

I_{CC} transients, including those produced by output switching, can produce voltage fluctuations, resulting in spikes on the V_{CC} bus. These transients can be reduced if capacitors are used to store energy which stabilizes the V_{CC} bus. The energy stored in the bypass capacitors will be released as low going spikes are generated or energy will be absorbed when overshoots occur. A ceramic bypass capacitor value of 0.1μF (as shown in Figure 11) is recommended in order to provide the needed filtering.

In addition to transients that are caused by normal SRAM operation, power cycling can generate negative voltage spikes on V_{CC} that drive it to values below V_{SS} by as much as one volt. These negative spikes can cause data corruption in the SRAM while in battery backup mode. To protect from these voltage spikes, it is recommended to connect a schottky diode from V_{CC} to V_{SS} (cathode connected to V_{CC}, anode to V_{SS}). Schottky diode 1N5817 is recommended for through hole and MBRS120T3 is recommended for surface mount.

Figure 11. Supply Voltage Protection

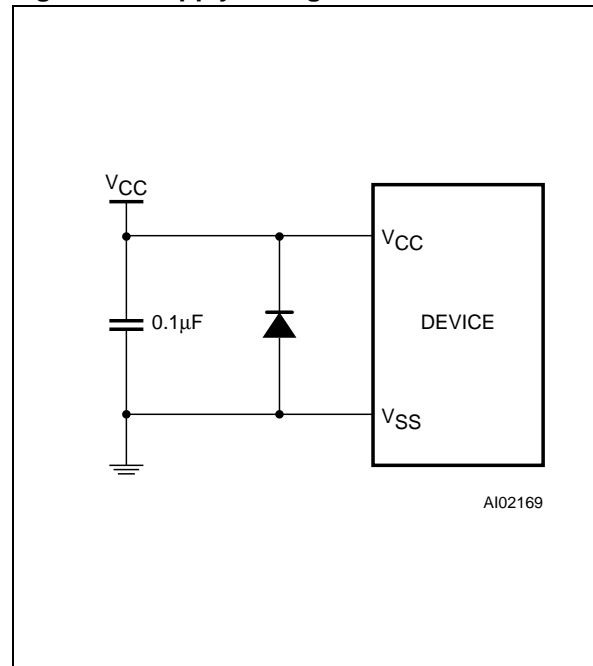

M48Z129Y*, M48Z129V

PART NUMBERING

Table 11. Ordering Information Scheme

Example:	M48Z	129Y	-70	PM	1	TR
Device Type	M48Z					
Supply Voltage and Write Protect Voltage		129Y ⁽¹⁾ = V _{CC} = 4.5 to 5.5V; 4.2V ≤ V _{PFD} ≤ 4.5V 129V = V _{CC} = 3.0 to 3.6V; 2.7V ≤ V _{PFD} ≤ 3.0V				
Speed			-70 = 70ns (M48Z129Y) -85 = 85ns (M48Z129V)			
Package				PM = PMDIP32		
Temperature Range					1 = 0 to 70°C	
Shipping Method						blank = Tubes TR = Tape & Reel

Note: 1. Contact Local Sales Office

For a list of available options (e.g., Speed, Package) or for further information on any aspect of this device, please contact the ST Sales Office nearest you.

PACKAGE MECHANICAL INFORMATION

Figure 12. PMDIP32 – 32-pin Plastic Module DIP, Package Outline

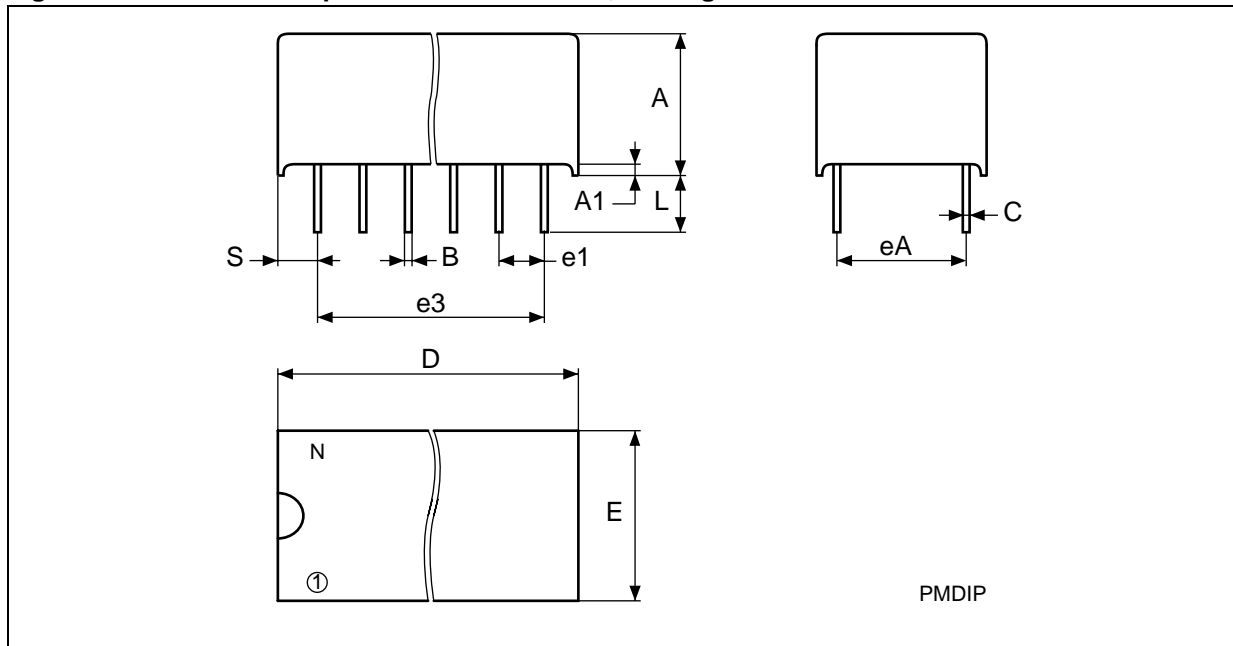

Note: Drawing is not to scale.

Table 12. PMDIP32 – 32-pin Plastic DIP, Package Mechanical Data

Symb	mm			inches			
	Typ	Min	Max	Typ	Min	Max	
A		9.27	9.52		0.365	0.375	
A1		0.38	–		0.015	–	
B		0.43	0.59		0.017	0.023	
C		0.20	0.33		0.008	0.013	
D		42.42	43.18		1.670	1.700	
E		18.03	18.80		0.710	0.740	
e1		2.29	2.79		0.090	0.110	
e3		34.29	41.91		1.350	1.650	
eA		14.99	16.00		0.590	0.630	
L		3.05	3.81		0.120	0.150	
S		1.91	2.79		0.075	0.110	
N		32			32		

REVISION HISTORY

Table 13. Document Revision History

Date	Revision Details
December 1999	First Issue
03/30/00	From Preliminary Data to Data Sheet
06/20/00	t _{GLQX} changed for M48Z129Y (Table 7)
09/14/01	Reformatted; Temperature information added to tables (Table 4, 5, 7, 8, 9, 10)
05/29/02	Add countries to disclaimer

Information furnished is believed to be accurate and reliable. However, STMicroelectronics assumes no responsibility for the consequences of use of such information nor for any infringement of patents or other rights of third parties which may result from its use. No license is granted by implication or otherwise under any patent or patent rights of STMicroelectronics. Specifications mentioned in this publication are subject to change without notice. This publication supersedes and replaces all information previously supplied. STMicroelectronics products are not authorized for use as critical components in life support devices or systems without express written approval of STMicroelectronics.

The ST logo is registered trademark of STMicroelectronics
All other names are the property of their respective owners.

© 2002 STMicroelectronics - All Rights Reserved

STMicroelectronics GROUP OF COMPANIES
Australia - Brazil - Canada - China - Finland - France - Germany - Hong Kong - India - Israel - Italy - Japan - Malaysia -
Malta - Morocco - Singapore - Spain - Sweden - Switzerland - United Kingdom - U.S.A.

www.st.com