

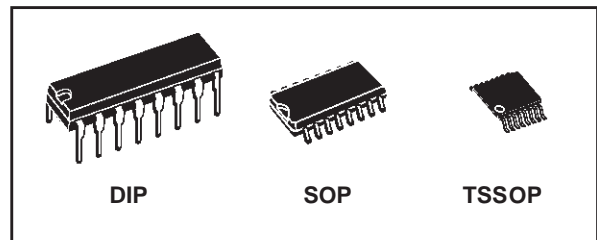

M74HC112

DUAL J-K FLIP FLOP WITH PRESET AND CLEAR

- HIGH SPEED :
 $f_{MAX} = 79\text{MHz}$ (TYP.) at $V_{CC} = 6\text{V}$
- LOW POWER DISSIPATION:
 $I_{CC} = 2\mu\text{A}$ (MAX.) at $T_A = 25^\circ\text{C}$
- HIGH NOISE IMMUNITY:
 $V_{NIH} = V_{NIL} = 28\% V_{CC}$ (MIN.)
- SYMMETRICAL OUTPUT IMPEDANCE:
 $|I_{OH}| = I_{OL} = 4\text{mA}$ (MIN)
- BALANCED PROPAGATION DELAYS:
 $t_{PLH} \approx t_{PHL}$
- WIDE OPERATING VOLTAGE RANGE:
 V_{CC} (OPR) = 2V to 6V
- PIN AND FUNCTION COMPATIBLE WITH
 74 SERIES 112



ORDER CODES

PACKAGE	TUBE	T & R
DIP	M74HC112B1R	
SOP	M74HC112M1R	M74HC112RM13TR
TSSOP		M74HC112TTR

DESCRIPTION

The M74HC112 is a high speed CMOS DUAL J-K FLIP-FLOP WITH PRESET AND CLEAR fabricated with silicon gate C²MOS technology. The M74HC112 dual JK flip-flop features individual J, K, clock, and asynchronous set and clear inputs for each flip-flop. When the clock goes high, the inputs are enabled and data will be accepted. The logic level of the J and K inputs

may be allowed to change when the clock pulse is high and the bistable will function as shown in the truth table. Input data is transferred to the input on the negative going edge of the clock pulse. All inputs are equipped with protection circuits against static discharge and transient excess voltage.

PIN CONNECTION AND IEC LOGIC SYMBOLS

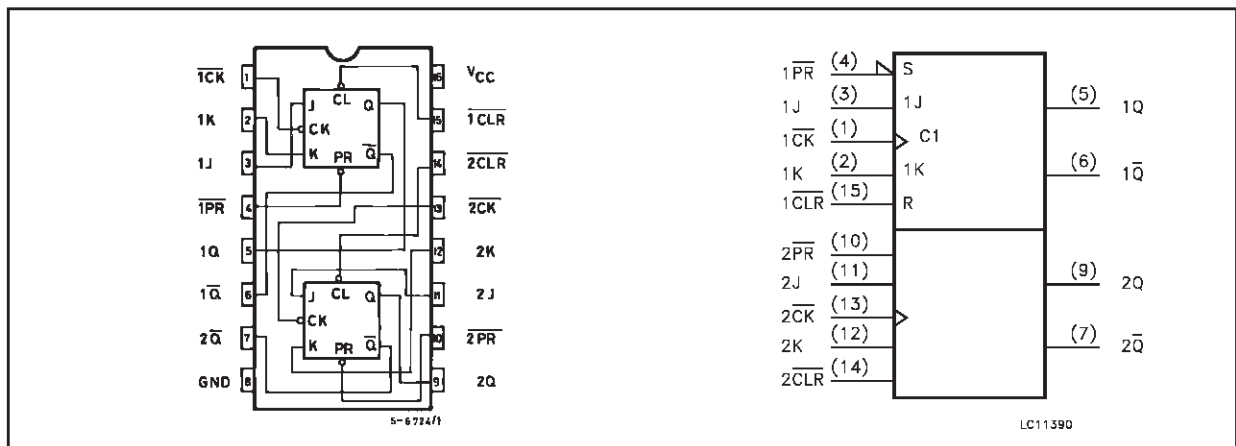

INPUT AND OUTPUT EQUIVALENT CIRCUIT

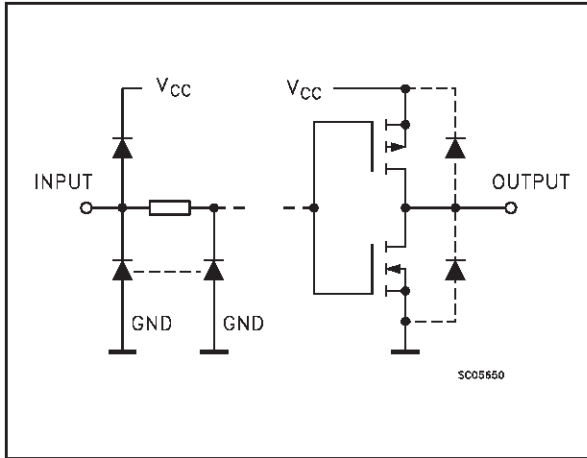

PIN DESCRIPTION

PIN No	SYMBOL	NAME AND FUNCTION
1, 13	$1\overline{CK}, 2\overline{CK}$	Clock Input(HIGH to LOW edge triggered)
2, 12	1K, 2K	Data Inputs: Flip-Flop 1 and 2
3, 11	1J, 2J	Data Inputs: Flip-Flop 1 and 2
4, 10	1PR, 2PR	Set Inputs
5, 9	1Q, 2Q	True Flip-Flop Outputs
6, 7	$1\overline{Q}, 2\overline{Q}$	Complement Flip-Flop Outputs
15, 14	$1\overline{CLR}, 2\overline{CLR}$	Reset Inputs
8	GND	Ground (0V)
16	Vcc	Positive Supply Voltage

TRUTH TABLE

INPUTS					OUTPUTS		FUNCTION
\overline{CLR}	\overline{PR}	J	K	CK	Q	\overline{Q}	
L	H	X	X	X	L	H	CLEAR
H	L	X	X	X	H	L	PRESET
L	L	X	X	X	H	H	----
H	H	L	L		Qn	\overline{Qn}	NO CHANGE
H	H	H	L		H	L	----
H	H	L	H		L	H	----
H	H	H	H		\overline{Qn}	Qn	TOGGLE
H	H	X	X		Qn	\overline{Qn}	NO CHANGE

X : Don't Care

LOGIC DIAGRAM

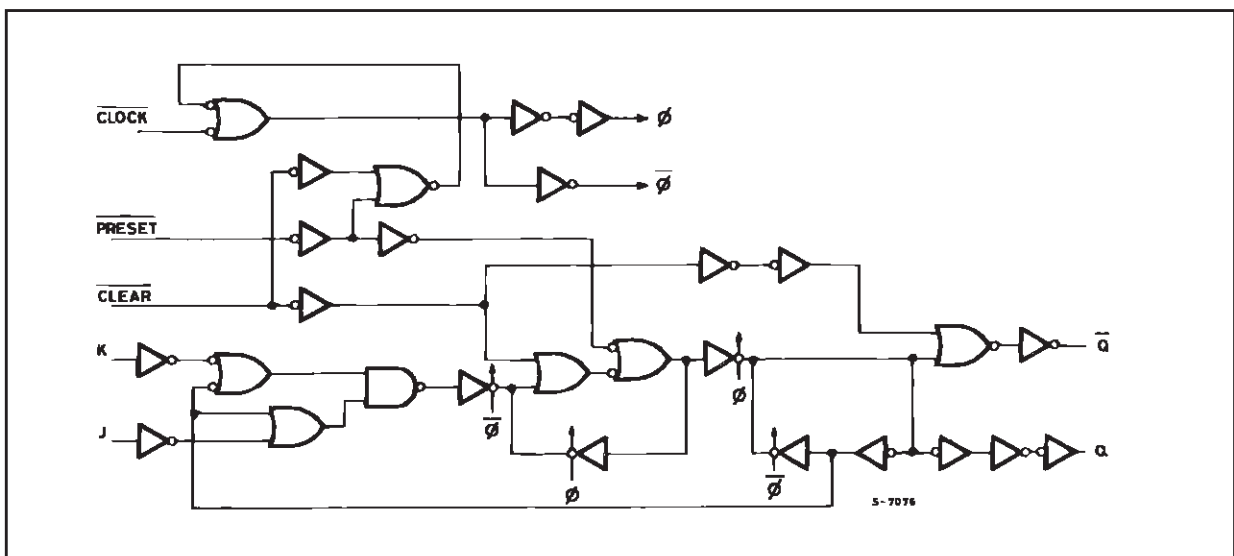

This logic diagram has not been used to estimate propagation delays

ABSOLUTE MAXIMUM RATINGS

Symbol	Parameter	Value	Unit
V_{CC}	Supply Voltage	-0.5 to +7	V
V_I	DC Input Voltage	-0.5 to $V_{CC} + 0.5$	V
V_O	DC Output Voltage	-0.5 to $V_{CC} + 0.5$	V
I_{IK}	DC Input Diode Current	± 20	mA
I_{OK}	DC Output Diode Current	± 20	mA
I_O	DC Output Current	± 25	mA
I_{CC} or I_{GND}	DC V_{CC} or Ground Current	± 50	mA
P_D	Power Dissipation	500(*)	mW
T_{stg}	Storage Temperature	-65 to +150	°C
T_L	Lead Temperature (10 sec)	300	°C

Absolute Maximum Ratings are those values beyond which damage to the device may occur. Functional operation under these conditions is not implied

(*) 500mW at 65 °C; derate to 300mW by 10mW/°C from 65°C to 85°C

RECOMMENDED OPERATING CONDITIONS

Symbol	Parameter	Value	Unit	
V_{CC}	Supply Voltage	2 to 6	V	
V_I	Input Voltage	0 to V_{CC}	V	
V_O	Output Voltage	0 to V_{CC}	V	
T_{op}	Operating Temperature	-55 to 125	°C	
t_r, t_f	Input Rise and Fall Time	$V_{CC} = 2.0V$	0 to 1000	ns
		$V_{CC} = 4.5V$	0 to 500	ns
		$V_{CC} = 6.0V$	0 to 400	ns

DC SPECIFICATIONS

Symbol	Parameter	Test Condition		Value						Unit	
		V _{CC} (V)		T _A = 25°C			-40 to 85°C		-55 to 125°C		
				Min.	Typ.	Max.	Min.	Max.	Min.		Max.
V _{IH}	High Level Input Voltage	2.0		1.5			1.5		1.5		V
		4.5		3.15			3.15		3.15		
		6.0		4.2			4.2		4.2		
V _{IL}	Low Level Input Voltage	2.0				0.5		0.5		0.5	V
		4.5				1.35		1.35		1.35	
		6.0				1.8		1.8		1.8	
V _{OH}	High Level Output Voltage	2.0	I _O =-20 μA	1.9	2.0		1.9		1.9		V
		4.5	I _O =-20 μA	4.4	4.5		4.4		4.4		
		6.0	I _O =-20 μA	5.9	6.0		5.9		5.9		
		4.5	I _O =-4.0 mA	4.18	4.31		4.13		4.10		
		6.0	I _O =-5.2 mA	5.68	5.8		5.63		5.60		
V _{OL}	Low Level Output Voltage	2.0	I _O =20 μA		0.0	0.1		0.1		0.1	V
		4.5	I _O =20 μA		0.0	0.1		0.1		0.1	
		6.0	I _O =20 μA		0.0	0.1		0.1		0.1	
		4.5	I _O =4.0 mA		0.17	0.26		0.33		0.40	
		6.0	I _O =5.2 mA		0.18	0.26		0.33		0.40	
I _I	Input Leakage Current	6.0	V _I = V _{CC} or GND			± 0.1		± 1		± 1	μA
I _{CC}	Quiescent Supply Current	6.0	V _I = V _{CC} or GND			2		20		40	μA

AC ELECTRICAL CHARACTERISTICS ($C_L = 50$ pF, Input $t_r = t_f = 6$ ns)

Symbol	Parameter	Test Condition		Value						Unit	
				$T_A = 25^\circ\text{C}$			-40 to 85°C		-55 to 125°C		
				V_{CC} (V)	Min.	Typ.	Max.	Min.	Max.		Min.
t_{TLH} t_{THL}	Output Transition Time	2.0		30	75		95		110	ns	
		4.5		8	15		19		22		
		6.0		7	13		16		19		
t_{PLH} t_{PHL}	Propagation Delay Time (CK - Q, \bar{Q})	2.0		52	125		155		190	ns	
		4.5		16	25		31		38		
		6.0		14	21		26		32		
t_{PLH} t_{PHL}	Propagation Delay Time (CLR, PR - Q, \bar{Q})	2.0		68	135		170		205	ns	
		4.5		17	27		34		41		
		6.0		14	23		29		35		
f_{MAX}	Maximum Clock Frequency	2.0		8	16		6.4		5.4	MHz	
		4.5		40	68		32		27		
		6.0		47	79		38		32		
$t_{W(H)}$ $t_{W(L)}$	Minimum Pulse Width (CLOCK)	2.0		20	75		95		110	ns	
		4.5		5	15		19		22		
		6.0		4	13		16		19		
$t_{W(L)}$	Minimum Pulse Width (CLR, PR)	2.0		20	75		95		110	ns	
		4.5		5	15		19		22		
		6.0		4	13		16		19		
t_s	Minimum Set-up Time	2.0		28	75		95		110	ns	
		4.5		7	15		19		22		
		6.0		6	13		16		19		
t_h	Minimum Hold Time	2.0			0		0		0	ns	
		4.5			0		0		0		
		6.0			0		0		0		
t_{REM}	Minimum Removal Time (CLR, PR)	2.0		24	50		60		70	ns	
		4.5		4	10		12		14		
		6.0		3	9		10		12		

CAPACITIVE CHARACTERISTICS

Symbol	Parameter	Test Condition		Value						Unit	
				$T_A = 25^\circ\text{C}$			-40 to 85°C		-55 to 125°C		
				V_{CC} (V)	Min.	Typ.	Max.	Min.	Max.		Min.
C_{IN}	Input Capacitance	5.0		5	10		10		10	pF	
C_{PD}	Power Dissipation Capacitance (note 1)	5.0		33						pF	

1) C_{PD} is defined as the value of the IC's internal equivalent capacitance which is calculated from the operating current consumption without load. (Refer to Test Circuit). Average operating current can be obtained by the following equation. $I_{CC(opr)} = C_{PD} \times V_{CC} \times f_{IN} + I_{CC}/2$ (per FLIP/FLOP)

TEST CIRCUIT

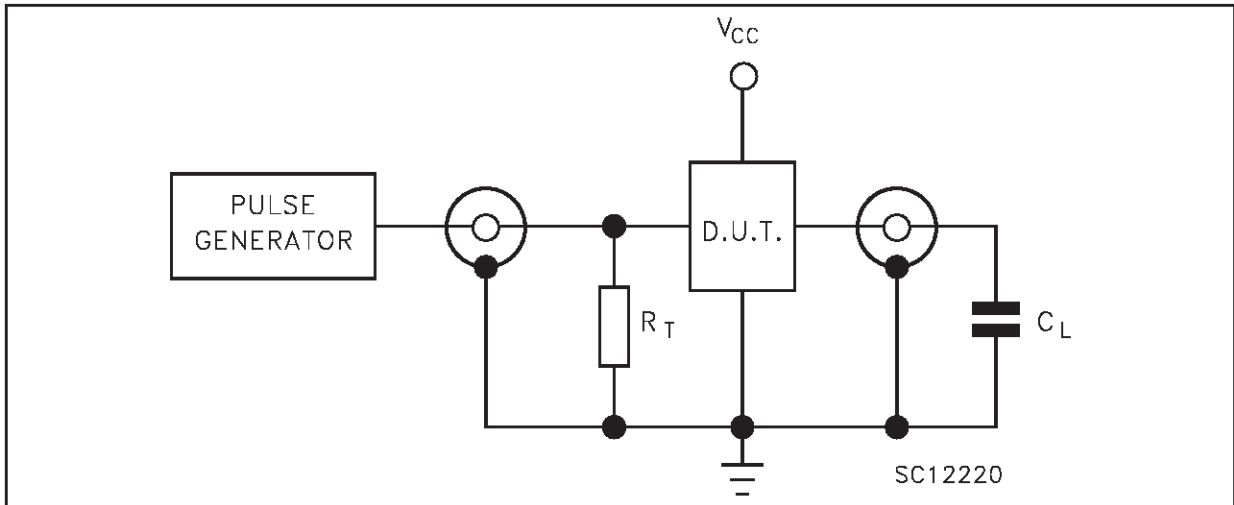

$C_L = 50\text{pF}$ or equivalent (includes jig and probe capacitance)
 $R_T = Z_{OUT}$ of pulse generator (typically 50Ω)

WAVEFORM 1: PROPAGATION DELAY TIMES, MINIMUM PULSE WIDTH (CK), SETUP AND HOLD TIME (J to CK) ($f=1\text{MHz}$; 50% duty cycle)

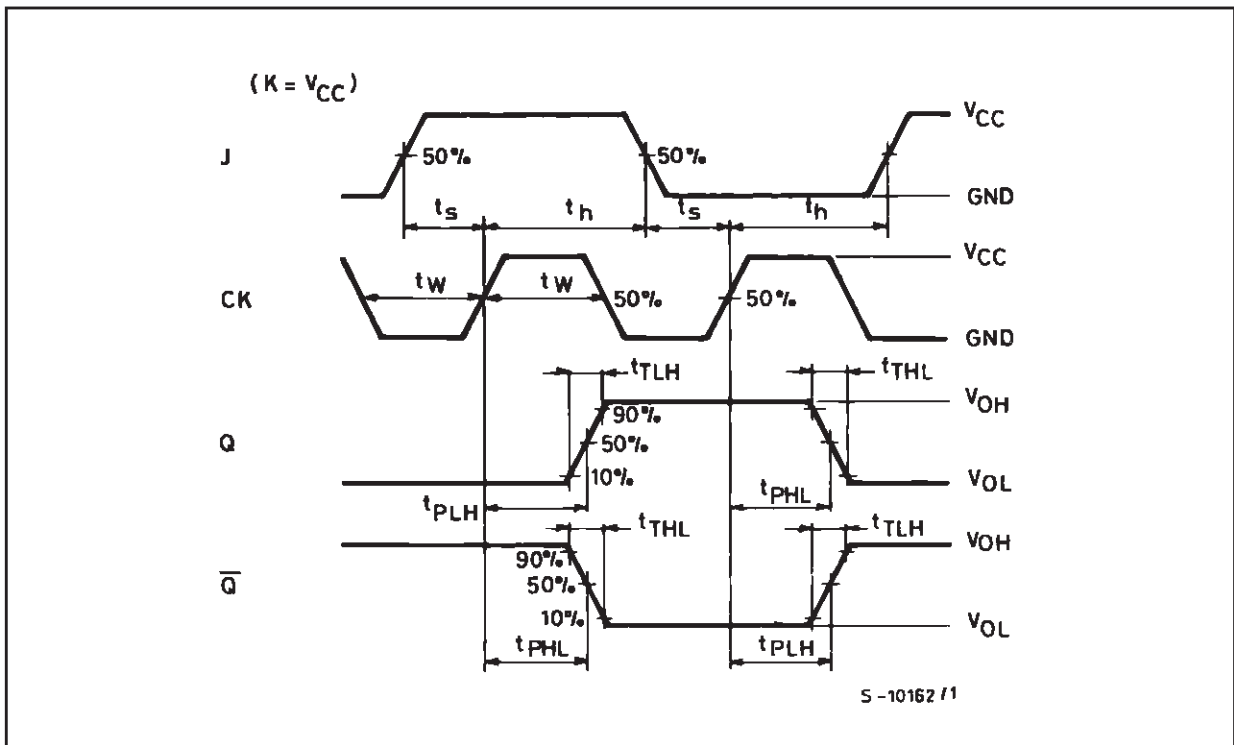

WAVEFORM 2 : PROPAGATIONS DELAY TIME, MINIMUM PULSE WIDTH ($\overline{\text{CLR}}$, $\overline{\text{PR}}$)

(f=1MHz; 50% duty cycle)

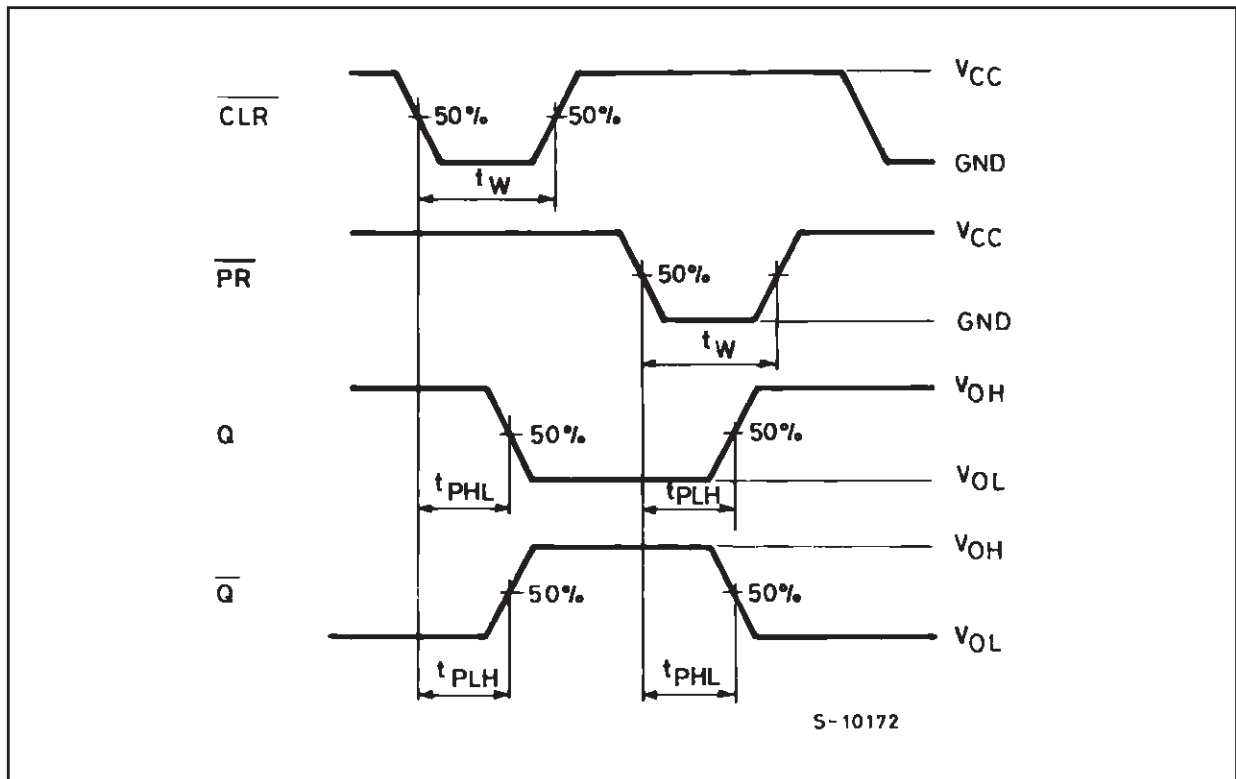

WAVEFORM 3 : MINIMUM REMOVAL TIME ($\overline{\text{CLR}}$ to $\overline{\text{CK}}$) (f=1MHz; 50% duty cycle)

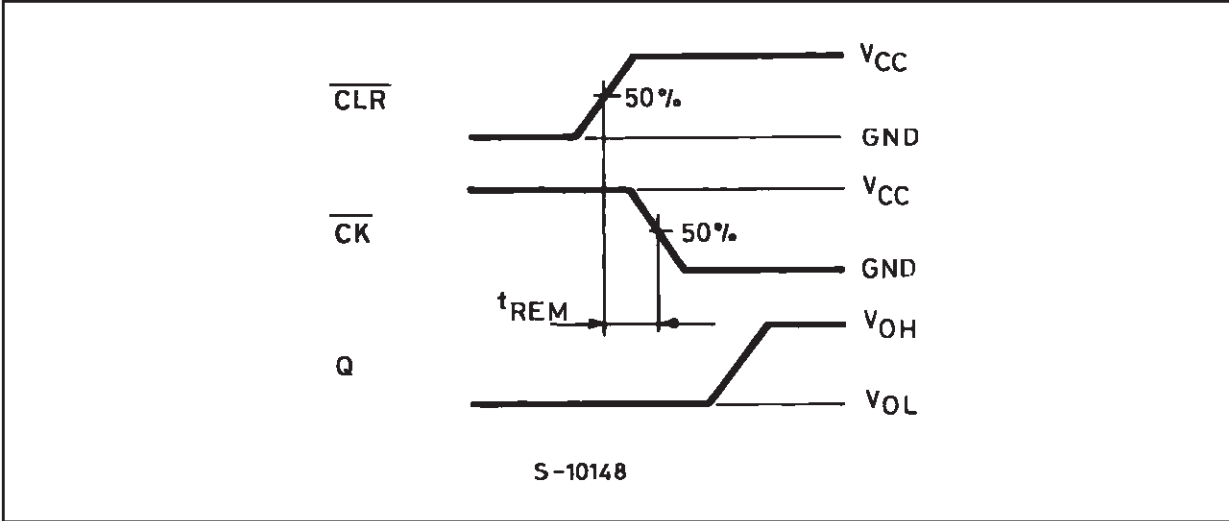

WAVEFORM 4 : MINIMUM REMOVAL TIME ($\overline{\text{PR}}$ to CK) (f=1MHz; 50% duty cycle)

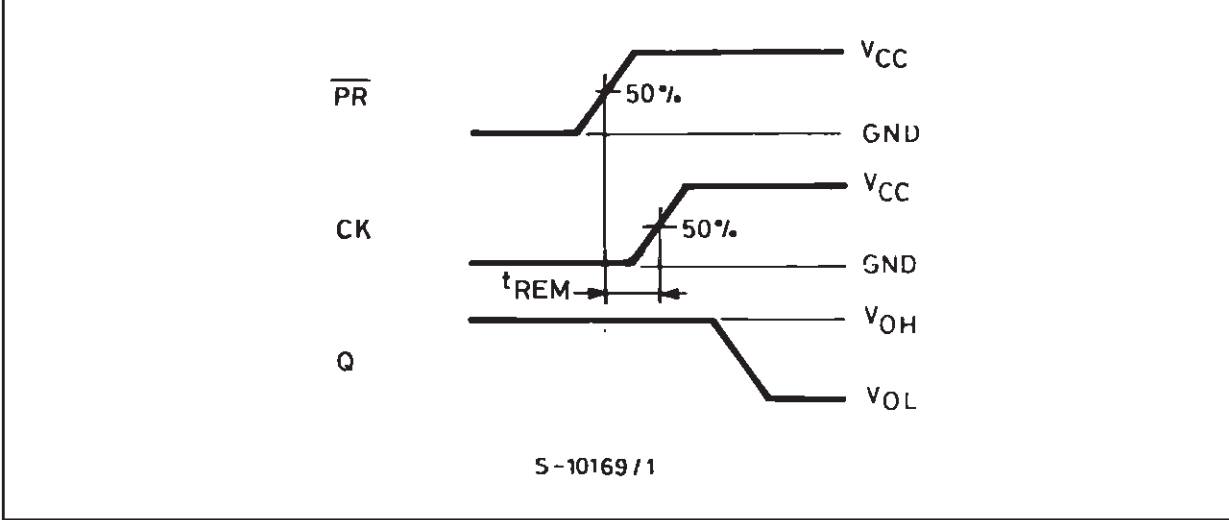

Plastic DIP-16 (0.25) MECHANICAL DATA

DIM.	mm.			inch		
	MIN.	TYP	MAX.	MIN.	TYP.	MAX.
a1	0.51			0.020		
B	0.77		1.65	0.030		0.065
b		0.5			0.020	
b1		0.25			0.010	
D			20			0.787
E		8.5			0.335	
e		2.54			0.100	
e3		17.78			0.700	
F			7.1			0.280
I			5.1			0.201
L		3.3			0.130	
Z			1.27			0.050

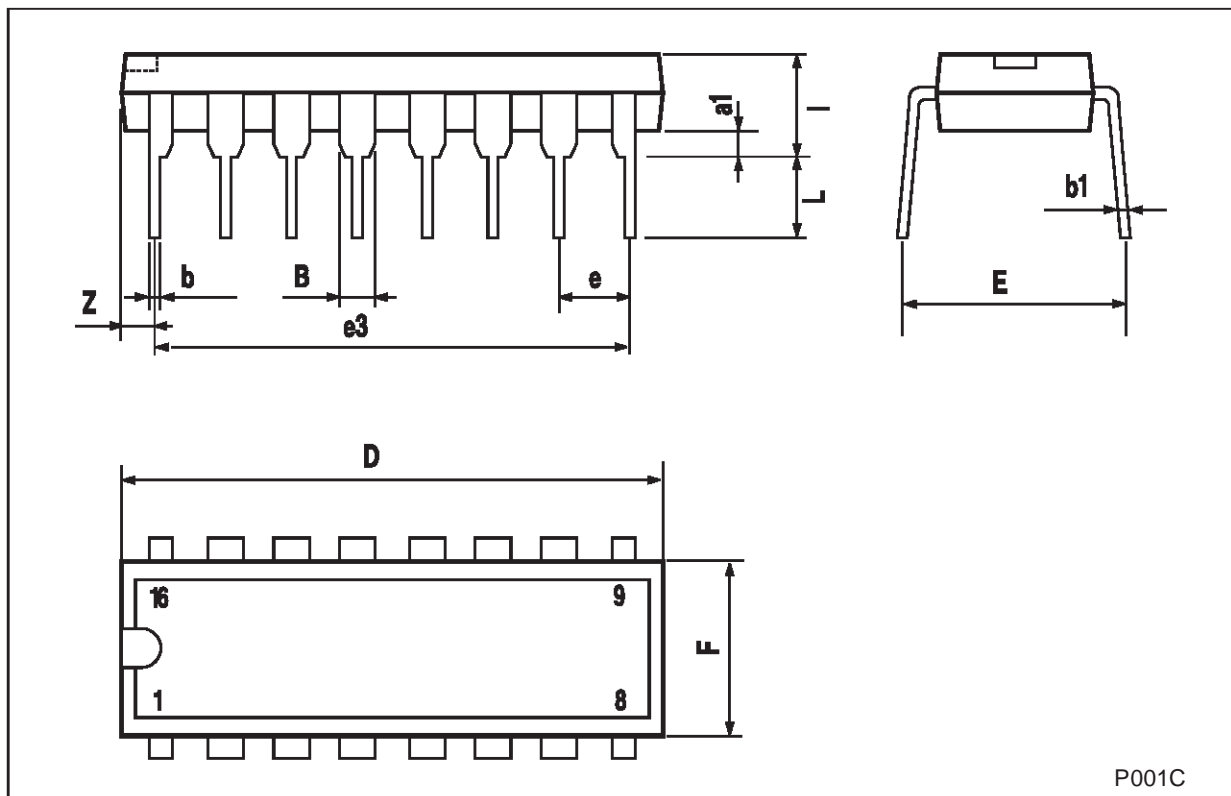

SO-16 MECHANICAL DATA

DIM.	mm.			inch		
	MIN.	TYP.	MAX.	MIN.	TYP.	MAX.
A			1.75			0.068
a1	0.1		0.2	0.003		0.007
a2			1.65			0.064
b	0.35		0.46	0.013		0.018
b1	0.19		0.25	0.007		0.010
C		0.5			0.019	
c1	45° (typ.)					
D	9.8		10	0.385		0.393
E	5.8		6.2	0.228		0.244
e		1.27			0.050	
e3		8.89			0.350	
F	3.8		4.0	0.149		0.157
G	4.6		5.3	0.181		0.208
L	0.5		1.27	0.019		0.050
M			0.62			0.024
S	8° (max.)					

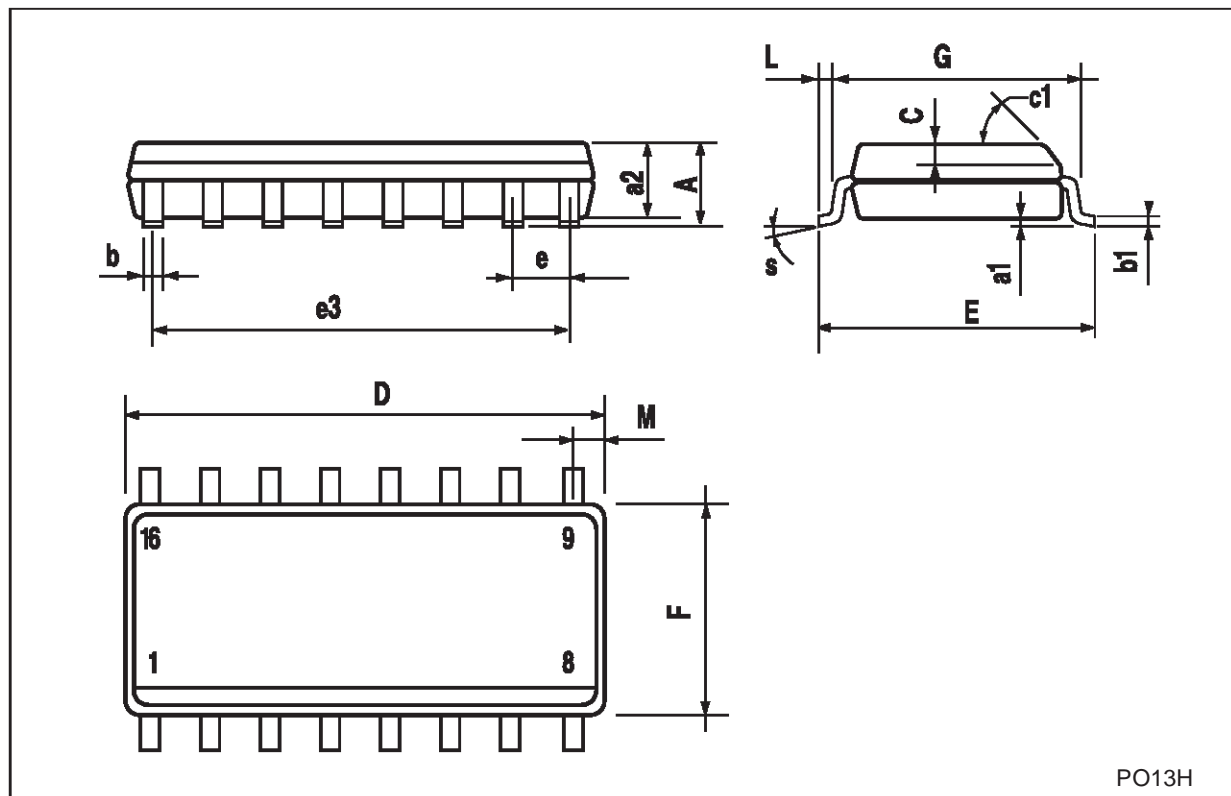

PO13H

TSSOP16 MECHANICAL DATA

DIM.	mm.			inch		
	MIN.	TYP	MAX.	MIN.	TYP.	MAX.
A			1.2			0.047
A1	0.05		0.15	0.002	0.004	0.006
A2	0.8	1	1.05	0.031	0.039	0.041
b	0.19		0.30	0.007		0.012
c	0.09		0.20	0.004		0.0089
D	4.9	5	5.1	0.193	0.197	0.201
E	6.2	6.4	6.6	0.244	0.252	0.260
E1	4.3	4.4	4.48	0.169	0.173	0.176
e		0.65 BSC			0.0256 BSC	
K	0°		8°	0°		8°
L	0.45	0.60	0.75	0.018	0.024	0.030

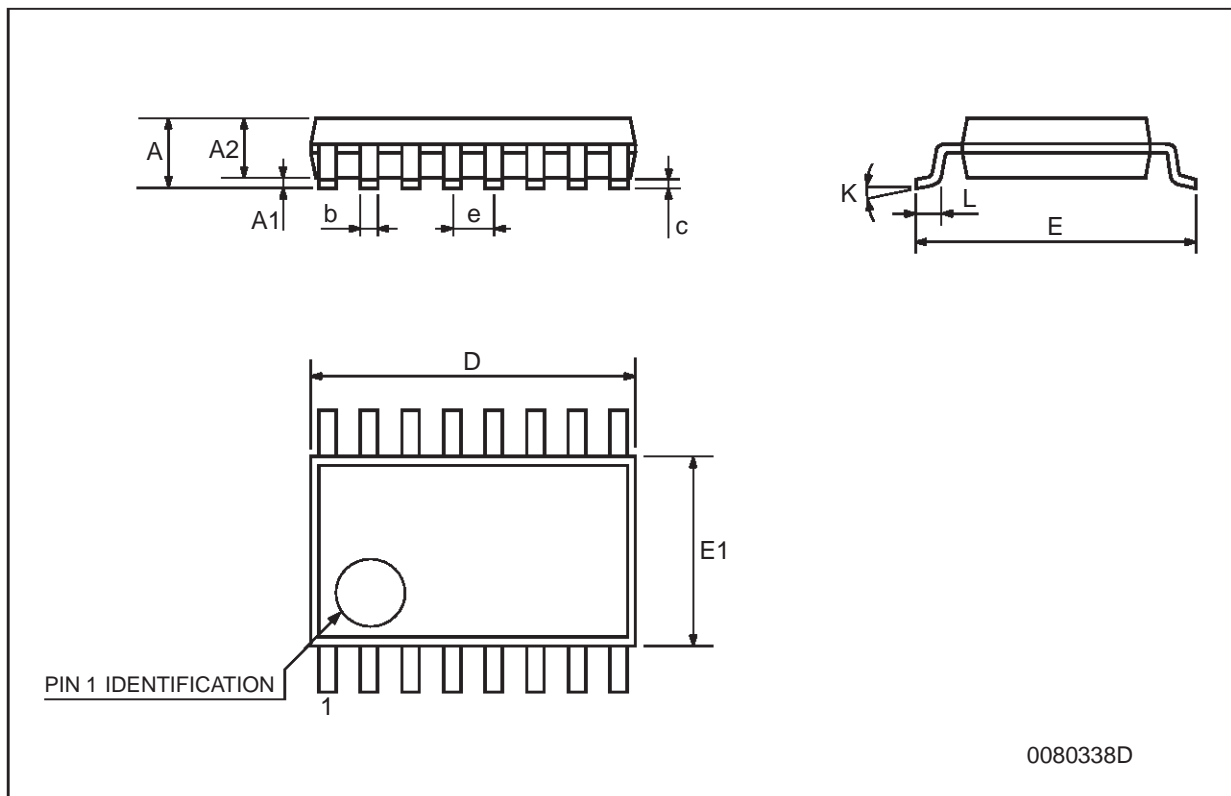

Information furnished is believed to be accurate and reliable. However, STMicroelectronics assumes no responsibility for the consequences of use of such information nor for any infringement of patents or other rights of third parties which may result from its use. No license is granted by implication or otherwise under any patent or patent rights of STMicroelectronics. Specifications mentioned in this publication are subject to change without notice. This publication supersedes and replaces all information previously supplied. STMicroelectronics products are not authorized for use as critical components in life support devices or systems without express written approval of STMicroelectronics.

© The ST logo is a registered trademark of STMicroelectronics

© 2001 STMicroelectronics - Printed in Italy - All Rights Reserved
STMicroelectronics GROUP OF COMPANIES

Australia - Brazil - China - Finland - France - Germany - Hong Kong - India - Italy - Japan - Malaysia - Malta - Morocco
Singapore - Spain - Sweden - Switzerland - United Kingdom

© <http://www.st.com>