

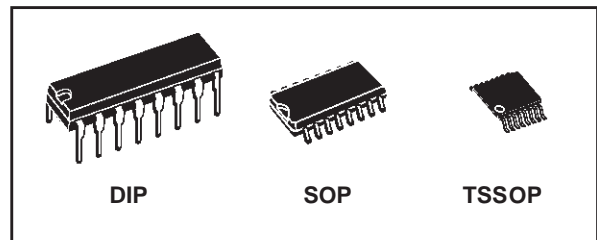

# M74HC190

## 4 BIT SYNCHRONOUS UP/DOWN COUNTERS

- HIGH SPEED :  
 $f_{MAX} = 44 \text{ MHz (TYP.) at } V_{CC} = 6V$
- LOW POWER DISSIPATION:  
 $I_{CC} = 4\mu\text{A (MAX.) at } T_A = 25^\circ\text{C}$
- HIGH NOISE IMMUNITY:  
 $V_{NIH} = V_{NIL} = 28 \% V_{CC} \text{ (MIN.)}$
- SYMMETRICAL OUTPUT IMPEDANCE:  
 $|I_{OH}| = I_{OL} = 4\text{mA (MIN)}$
- BALANCED PROPAGATION DELAYS:  
 $t_{PLH} \approx t_{PHL}$
- WIDE OPERATING VOLTAGE RANGE:  
 $V_{CC} \text{ (OPR)} = 2V \text{ to } 6V$
- PIN AND FUNCTION COMPATIBLE WITH  
 74 SERIES 190



### ORDER CODES

PACKAGE	TUBE	T & R
DIP	M74HC190B1R	
SOP	M74HC190M1R	M74HC190RM13TR
TSSOP		M74HC190TTR

### DESCRIPTION

The M74HC190 is an high speed CMOS 4-BIT SYNCHRONOUS UP/DOWN COUNTER fabricated with silicon gate C<sup>2</sup>MOS technology. State changes of the counter are synchronous with the LOW-to-HIGH transition of the Clock Pulse Input.

An asynchronous parallel load input overrides counting and loads the data present on the DATA inputs into the flip-flops, which makes it possible to use the circuits as programmable counters. A count enable input serves as the carry/borrow

input in multi-stage counters. Control input, Down/Up, determines whether a circuit counts up or down. A MAX/MIN output and a Ripple Clock output provide overflow/underflow indication and make possible a variety of methods for generating carry/borrow signals in multi-stage counter applications.

All inputs are equipped with protection circuits against static discharge and transient excess voltage.

### PIN CONNECTION AND IEC LOGIC SYMBOLS

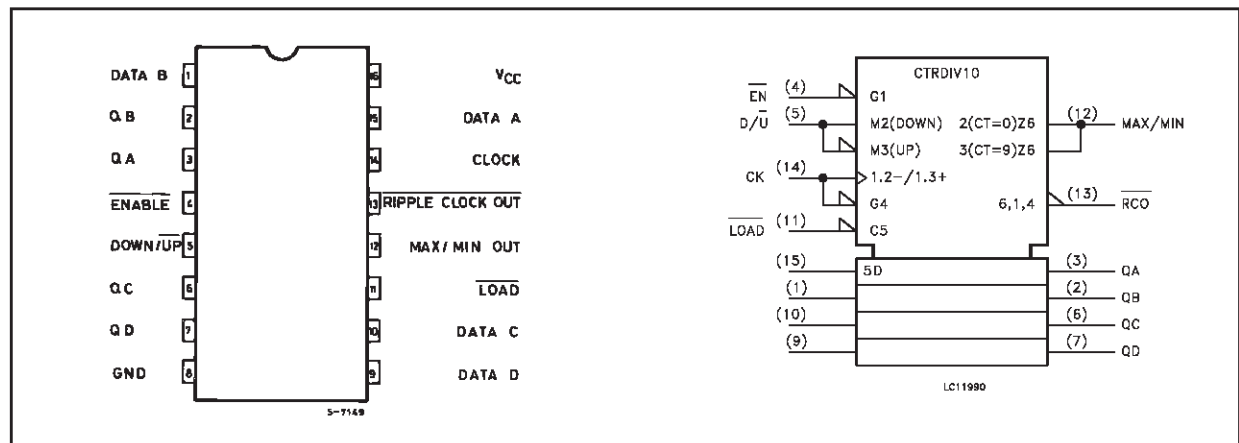

INPUT AND OUTPUT EQUIVALENT CIRCUIT

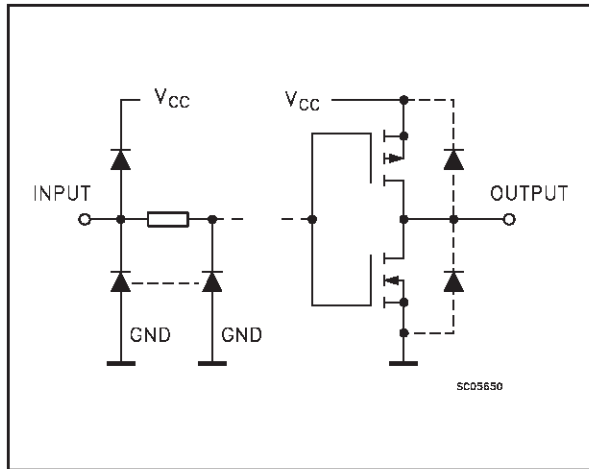

PIN DESCRIPTION

PIN No	SYMBOL	NAME AND FUNCTION
3, 2, 6, 7	QA to QD	Flip-Flop Outputs
4	$\overline{\text{ENABLE}}$	Count Enable Input (Active LOW)
5	$\overline{\text{D/U}}$	Parallel Data Input
11	$\overline{\text{LOAD}}$	Load Input (Active LOW)
12	MAX/MIN	Terminal Count Output
13	$\overline{\text{RCO}}$	Ripple Clock Output (Active LOW)
14	CLOCK	Clock Input (LOW to HIGH, edge triggered)
15, 1, 10, 9	DATA A to D	Data Inputs
8	GND	Ground (0V)
16	Vcc	Positive Supply Voltage

TRUTH TABLE

INPUTS				OUTPUTS				FUNCTION
$\overline{\text{LOAD}}$	$\overline{\text{ENABLE}}$	$\overline{\text{D/U}}$	CLOCK	QA	QB	QC	QD	
L	X	X	X	a	b	c	d	PRESET DATA
H	L	L	⌋	UP COUNT				UP COUNT
H	L	H	⌋	DOWN COUNT				DOWN COUNT
H	H	X	⌋	NO CHANGE				NO COUNT
H	X	X	⌋	NO CHANGE				NO COUNT

X : Don't Care  
a - d : The level of steady state inputs a through d respectively

LOGIC DIAGRAM

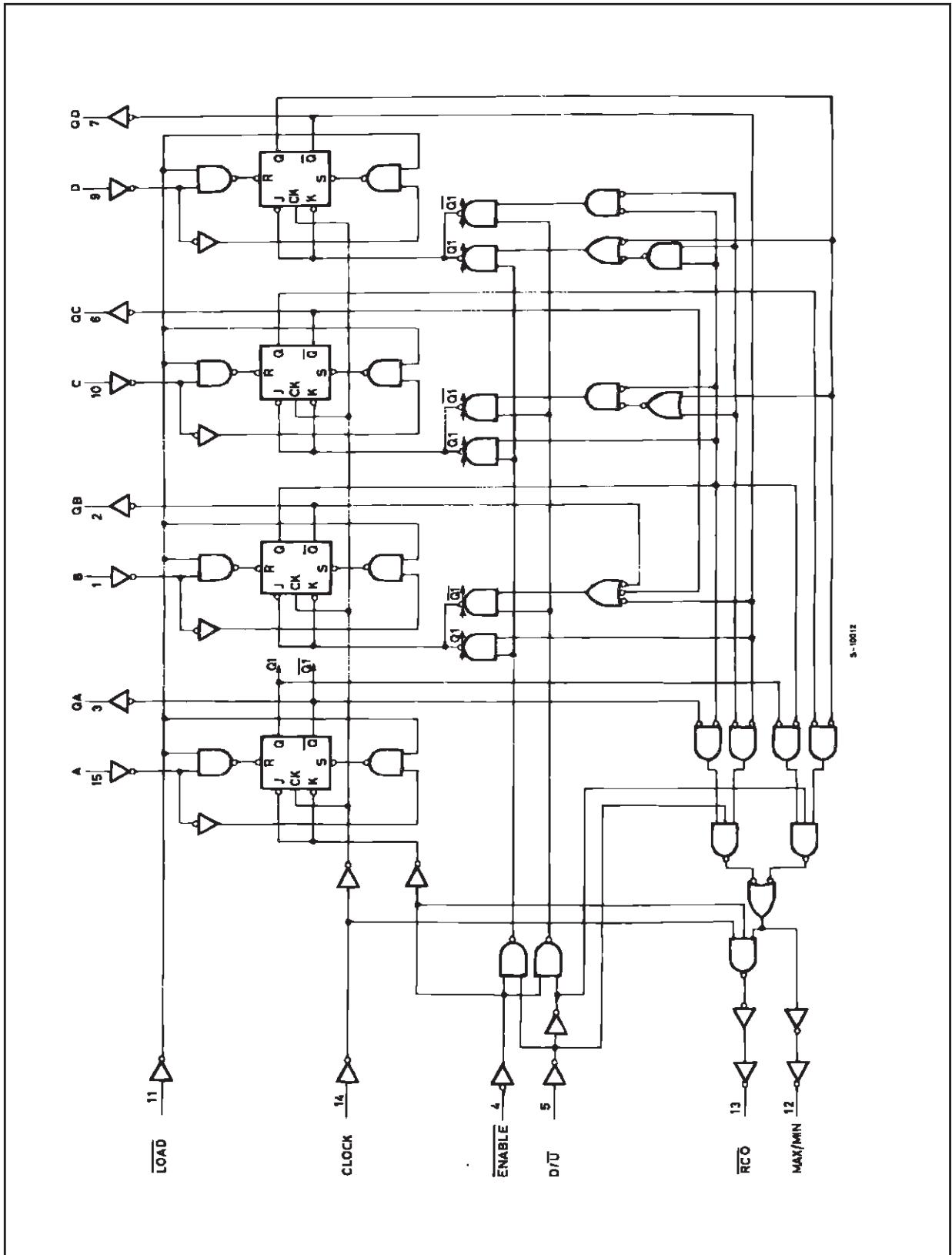

This logic diagram has not be used to estimate propagation delays



TIMING CHART

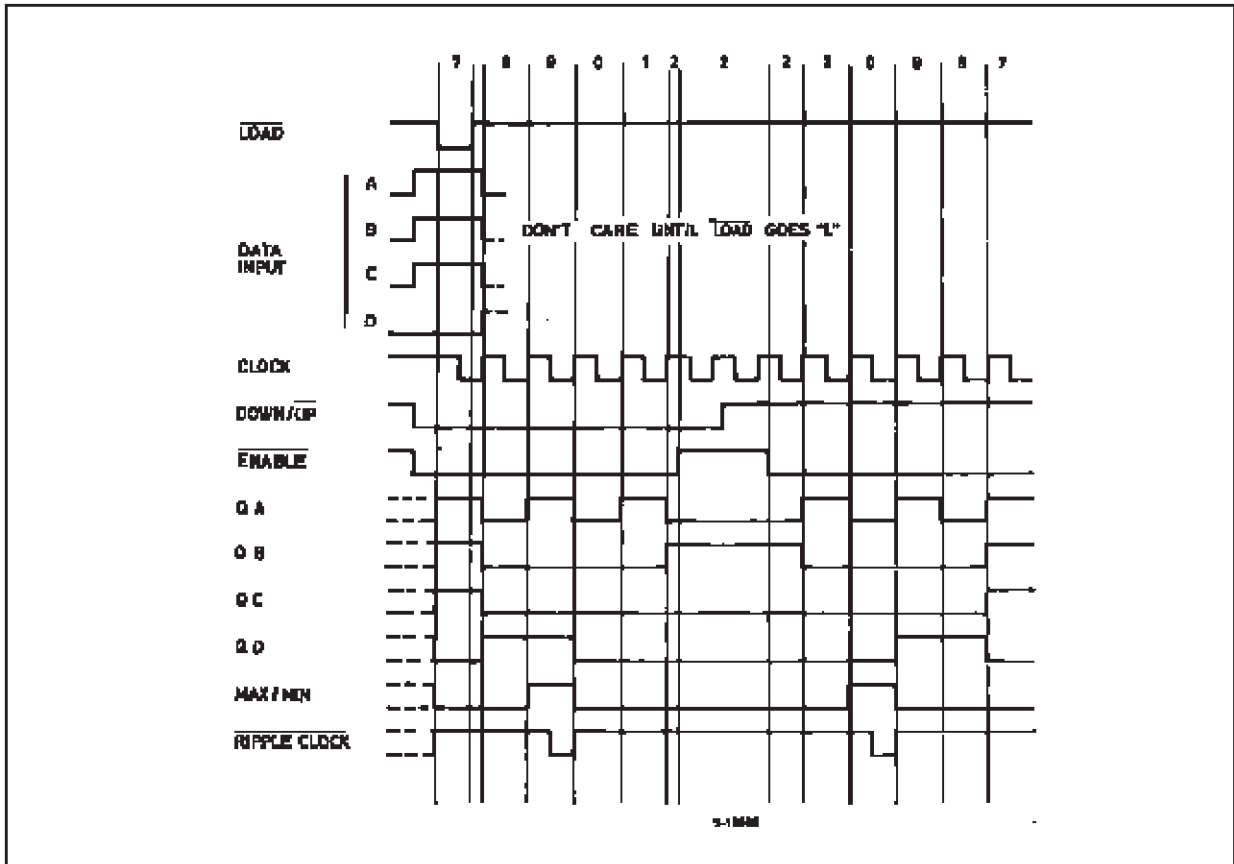

ABSOLUTE MAXIMUM RATINGS

Symbol	Parameter	Value	Unit
V <sub>CC</sub>	Supply Voltage	-0.5 to +7	V
V <sub>I</sub>	DC Input Voltage	-0.5 to V <sub>CC</sub> + 0.5	V
V <sub>O</sub>	DC Output Voltage	-0.5 to V <sub>CC</sub> + 0.5	V
I <sub>IK</sub>	DC Input Diode Current	± 20	mA
I <sub>OK</sub>	DC Output Diode Current	± 20	mA
I <sub>O</sub>	DC Output Current	± 25	mA
I <sub>CC</sub> or I <sub>GND</sub>	DC V <sub>CC</sub> or Ground Current	± 50	mA
P <sub>D</sub>	Power Dissipation	500(*)	mW
T <sub>stg</sub>	Storage Temperature	-65 to +150	°C
T <sub>L</sub>	Lead Temperature (10 sec)	300	°C

Absolute Maximum Ratings are those values beyond which damage to the device may occur. Functional operation under these conditions is not implied  
 (\*) 500mW at 65 °C; derate to 300mW by 10mW/°C from 65°C to 85°C

## RECOMMENDED OPERATING CONDITIONS

Symbol	Parameter	Value	Unit	
$V_{CC}$	Supply Voltage	2 to 6	V	
$V_I$	Input Voltage	0 to $V_{CC}$	V	
$V_O$	Output Voltage	0 to $V_{CC}$	V	
$T_{op}$	Operating Temperature	-55 to 125	°C	
$t_r, t_f$	Input Rise and Fall Time	$V_{CC} = 2.0V$	0 to 1000	ns
		$V_{CC} = 4.5V$	0 to 500	ns
		$V_{CC} = 6.0V$	0 to 400	ns

## DC SPECIFICATIONS

Symbol	Parameter	Test Condition		Value						Unit	
		$V_{CC}$ (V)		$T_A = 25^\circ C$			-40 to 85°C		-55 to 125°C		
				Min.	Typ.	Max.	Min.	Max.	Min.		Max.
$V_{IH}$	High Level Input Voltage	2.0		1.5			1.5		1.5		V
		4.5		3.15			3.15		3.15		
		6.0		4.2			4.2		4.2		
$V_{IL}$	Low Level Input Voltage	2.0				0.5		0.5		0.5	V
		4.5				1.35		1.35		1.35	
		6.0				1.8		1.8		1.8	
$V_{OH}$	High Level Output Voltage	2.0	$I_O = -20 \mu A$	1.9	2.0		1.9		1.9		V
		4.5	$I_O = -20 \mu A$	4.4	4.5		4.4		4.4		
		6.0	$I_O = -20 \mu A$	5.9	6.0		5.9		5.9		
		4.5	$I_O = -4.0 mA$	4.18	4.31		4.13		4.10		
		6.0	$I_O = -5.2 mA$	5.68	5.8		5.63		5.60		
$V_{OL}$	Low Level Output Voltage	2.0	$I_O = 20 \mu A$		0.0	0.1		0.1		0.1	V
		4.5	$I_O = 20 \mu A$		0.0	0.1		0.1		0.1	
		6.0	$I_O = 20 \mu A$		0.0	0.1		0.1		0.1	
		4.5	$I_O = 4.0 mA$		0.17	0.26		0.33		0.40	
		6.0	$I_O = 5.2 mA$		0.18	0.26		0.33		0.40	
$I_I$	Input Leakage Current	6.0	$V_I = V_{CC}$ or GND			$\pm 0.1$		$\pm 1$		$\pm 1$	$\mu A$
$I_{CC}$	Quiescent Supply Current	6.0	$V_I = V_{CC}$ or GND			4		40		80	$\mu A$

AC ELECTRICAL CHARACTERISTICS ( $C_L = 50 \text{ pF}$ , Input  $t_r = t_f = 6 \text{ ns}$ )

Symbol	Parameter	Test Condition		Value						Unit	
		$V_{CC}$ (V)		$T_A = 25^\circ\text{C}$			$-40 \text{ to } 85^\circ\text{C}$		$-55 \text{ to } 125^\circ\text{C}$		
				Min.	Typ.	Max.	Min.	Max.	Min.		Max.
$t_{TLH}$ $t_{THL}$	Output Transition Time	2.0			30	75		95		110	ns
		4.5			8	15		19		22	
		6.0			7	13		16		19	
$t_{PLH}$ $t_{PHL}$	Propagation Delay Time (CLOCK - Q)	2.0			92	180		225		270	ns
		4.5			23	36		45		54	
		6.0			20	31		38		46	
$t_{PLH}$ $t_{PHL}$	Propagation Delay Time (CLOCK - $\overline{\text{RCO}}$ )	2.0			39	120		150		180	ns
		4.5			13	24		30		36	
		6.0			11	20		26		31	
$t_{PLH}$ $t_{PHL}$	Propagation Delay Time (CLOCK - MAX/MIN)	2.0			120	240		300		360	ns
		4.5			30	48		60		72	
		6.0			26	41		51		61	
$t_{PLH}$ $t_{PHL}$	Propagation Delay Time (LOAD - Q)	2.0			108	205		255		310	ns
		4.5			27	41		51		61	
		6.0			23	35		43		53	
$t_{PLH}$ $t_{PHL}$	Propagation Delay Time (DATA - Q)	2.0			84	175		220		265	ns
		4.5			21	35		44		53	
		6.0			18	30		37		45	
$t_{PLH}$ $t_{PHL}$	Propagation Delay Time (ENABLE - RCO)	2.0			39	105		130		160	ns
		4.5			13	21		26		32	
		6.0			11	18		22		27	
$t_{PLH}$ $t_{PHL}$	Propagation Delay Time (D/U - RCO)	2.0			63	180		225		270	ns
		4.5			21	36		45		54	
		6.0			18	31		38		46	
$t_{PLH}$ $t_{PHL}$	Propagation Delay Time (D/U - MAX/MIN)	2.0			64	160		200		240	ns
		4.5			18	32		40		48	
		6.0			15	27		34		41	
$f_{MAX}$	Maximum Clock Frequency	2.0			5	9		4		3.4	MHz
		4.5			25	37		20		17	
		6.0			30	44		24		20	
$t_{W(H)}$ $t_{W(L)}$	Minimum Pulse Width (CLOCK)	2.0			40	100		125		150	ns
		4.5			10	20		25		30	
		6.0			9	17		21		26	
$t_{W(L)}$	Minimum Pulse Width (LOAD)	2.0			36	75		95		110	ns
		4.5			9	15		19		22	
		6.0			8	13		16		19	
$t_s$	Minimum Set-up Time(SI, PI - CK)	2.0			80	175		220		265	ns
		4.5			20	35		44		53	
		6.0			17	30		37		45	
$t_s$	Minimum Set-up Time(S0, S1 - CLOCK)	2.0			16	50		60		75	ns
		4.5			4	10		12		15	
		6.0			3	9		11		13	

Symbol	Parameter	Test Condition		Value						Unit	
		V <sub>CC</sub> (V)		T <sub>A</sub> = 25°C			-40 to 85°C		-55 to 125°C		
				Min.	Typ.	Max.	Min.	Max.	Min.		Max.
t <sub>h</sub>	Minimum Hold Time	2.0				0		0		0	ns
		4.5				0		0		0	
		6.0					0		0		
t <sub>REM</sub>	Minimum Removal Time (CLEAR)	2.0			12	50		60		65	ns
		4.5			3	10		12		15	
		6.0			3	9		11		13	

### CAPACITIVE CHARACTERISTICS

Symbol	Parameter	Test Condition		Value						Unit	
		V <sub>CC</sub> (V)		T <sub>A</sub> = 25°C			-40 to 85°C		-55 to 125°C		
				Min.	Typ.	Max.	Min.	Max.	Min.		Max.
C <sub>IN</sub>	Input Capacitance	5.0			5	10		10		10	pF
C <sub>PD</sub>	Power Dissipation Capacitance (note 1)	5.0			111						pF

1) C<sub>PD</sub> is defined as the value of the IC's internal equivalent capacitance which is calculated from the operating current consumption without load. (Refer to Test Circuit). Average operating current can be obtained by the following equation.  $I_{CC(opr)} = C_{PD} \times V_{CC} \times f_{IN} + I_{CC}$

### TEST CIRCUIT

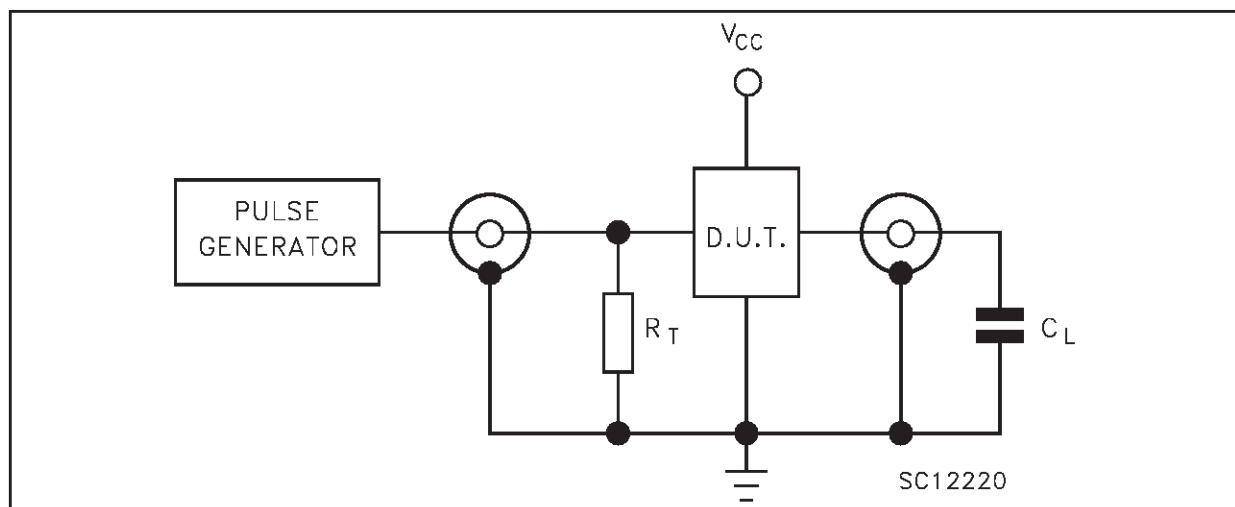

C<sub>L</sub> = 50pF or equivalent (includes jig and probe capacitance)  
R<sub>T</sub> = Z<sub>OUT</sub> of pulse generator (typically 50Ω)

WAVEFORM 1: PROPAGATION DELAY TIMES, MINIMUM PULSE WIDTH (CLOCK) (f=1MHz; 50% duty cycle)

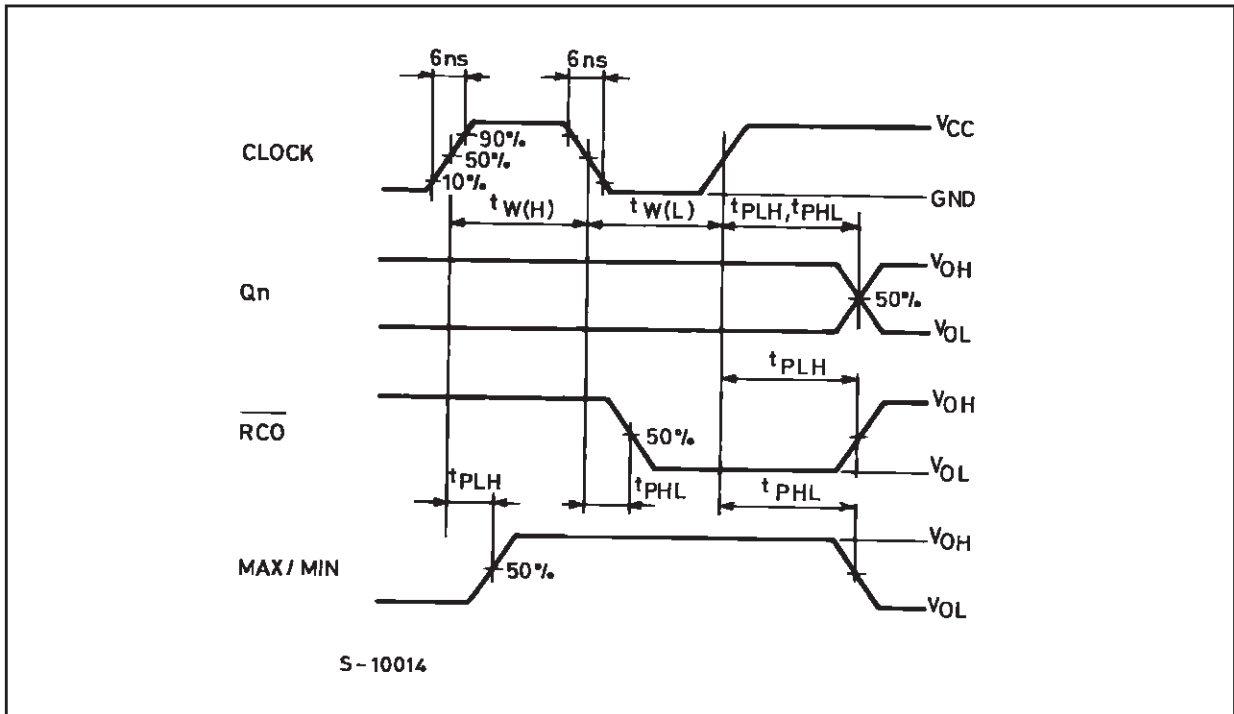

WAVEFORM 2 : PROPAGATION DELAY TIME, SETUP AND HOLD TIME (A-D TO  $\overline{\text{LOAD}}$ ) (f=1MHz; 50% duty cycle)

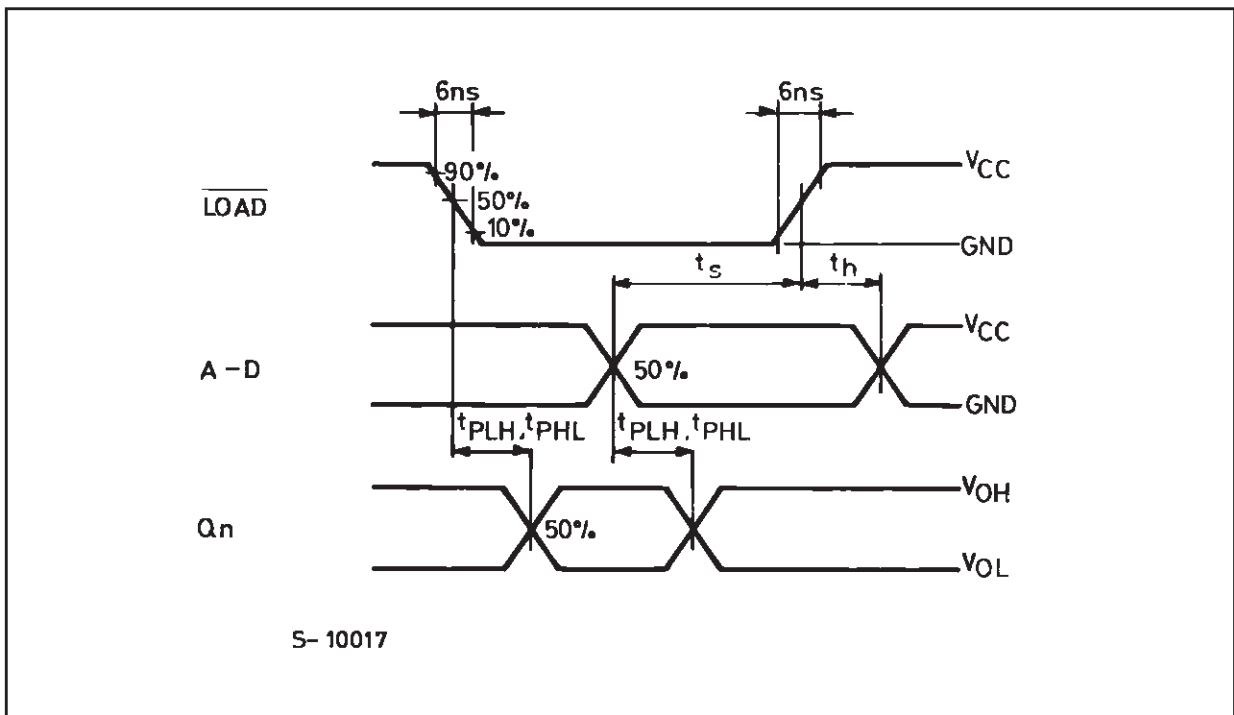

**WAVEFORM 3 : MINIMUM PULSE WIDTH ( $\overline{\text{LOAD}}$ ) AND REMOVAL TIME ( $\overline{\text{LOAD}}$  TO CLOCK) ( $f=1\text{MHz}$ ; 50% duty cycle)**

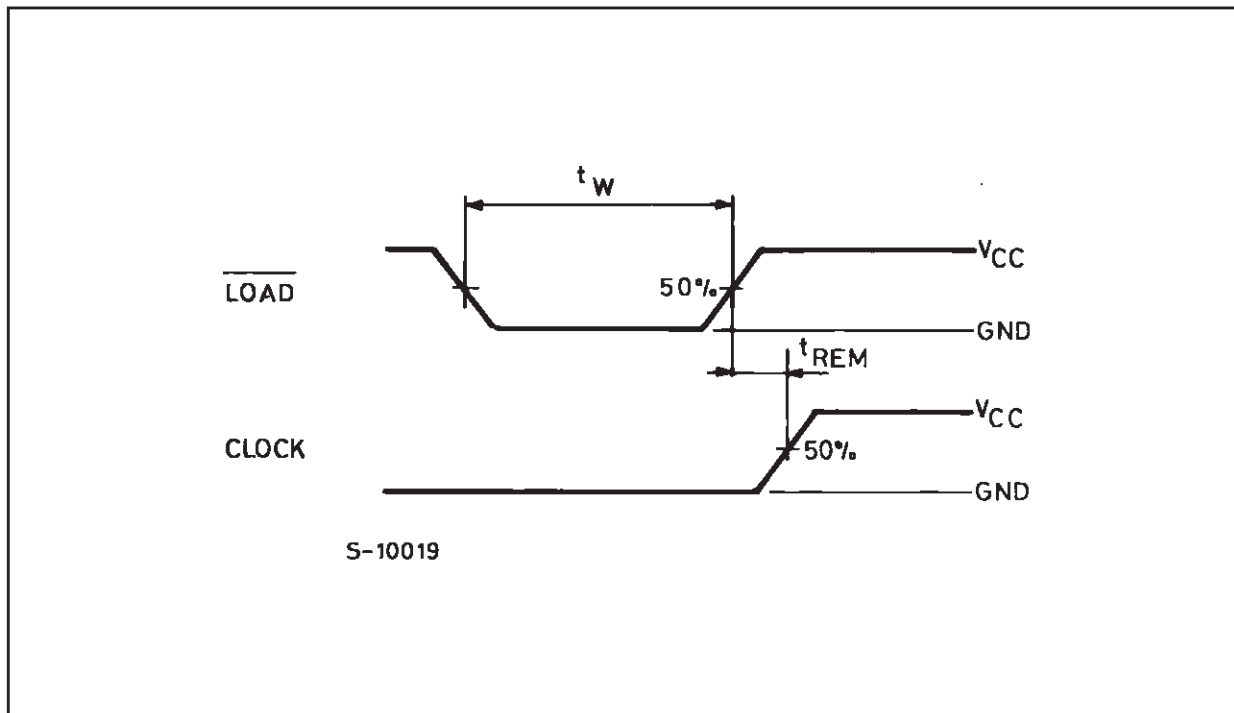

**WAVEFORM 4 : PROPAGATION DELAY TIME ( $f=1\text{MHz}$ ; 50% duty cycle)**

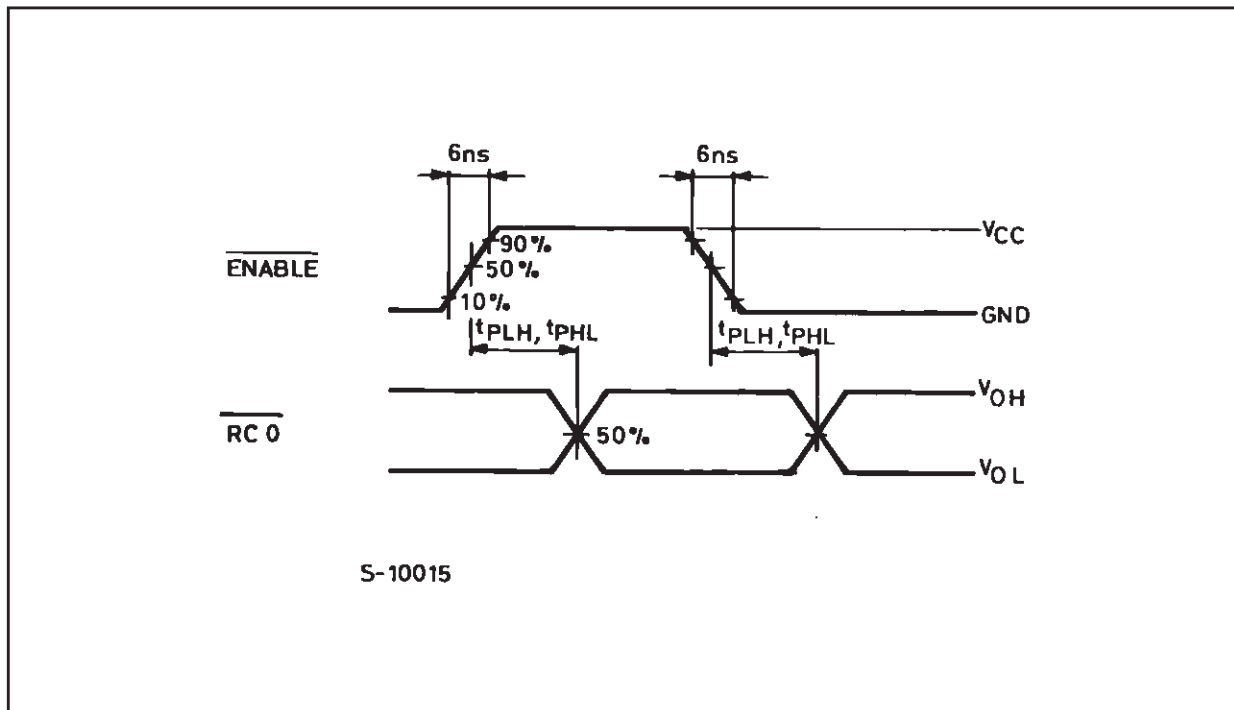

WAVEFORM 5 : PROPAGATION DELAY TIME (f=1MHz; 50% duty cycle)

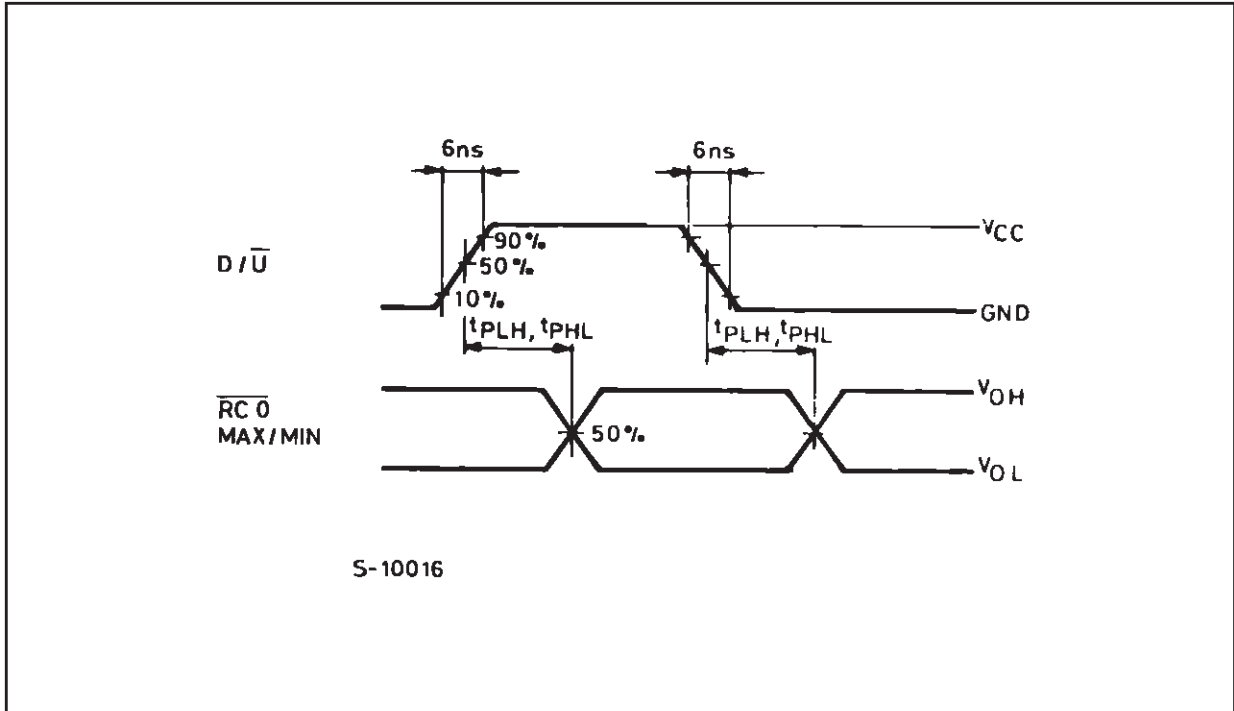

WAVEFORM 6 : SETUP AND HOLD TIME (f=1MHz; 50% duty cycle)

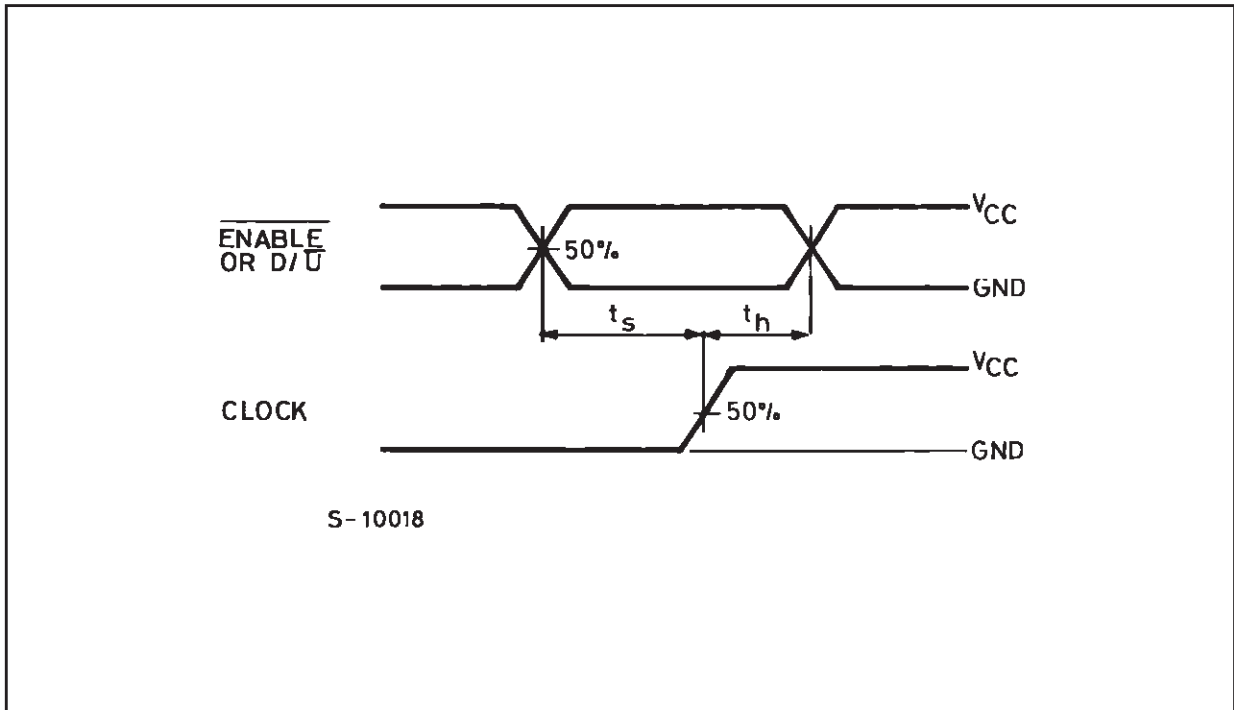

**Plastic DIP-16 (0.25) MECHANICAL DATA**

DIM.	mm.			inch		
	MIN.	TYP	MAX.	MIN.	TYP.	MAX.
a1	0.51			0.020		
B	0.77		1.65	0.030		0.065
b		0.5			0.020	
b1		0.25			0.010	
D			20			0.787
E		8.5			0.335	
e		2.54			0.100	
e3		17.78			0.700	
F			7.1			0.280
I			5.1			0.201
L		3.3			0.130	
Z			1.27			0.050

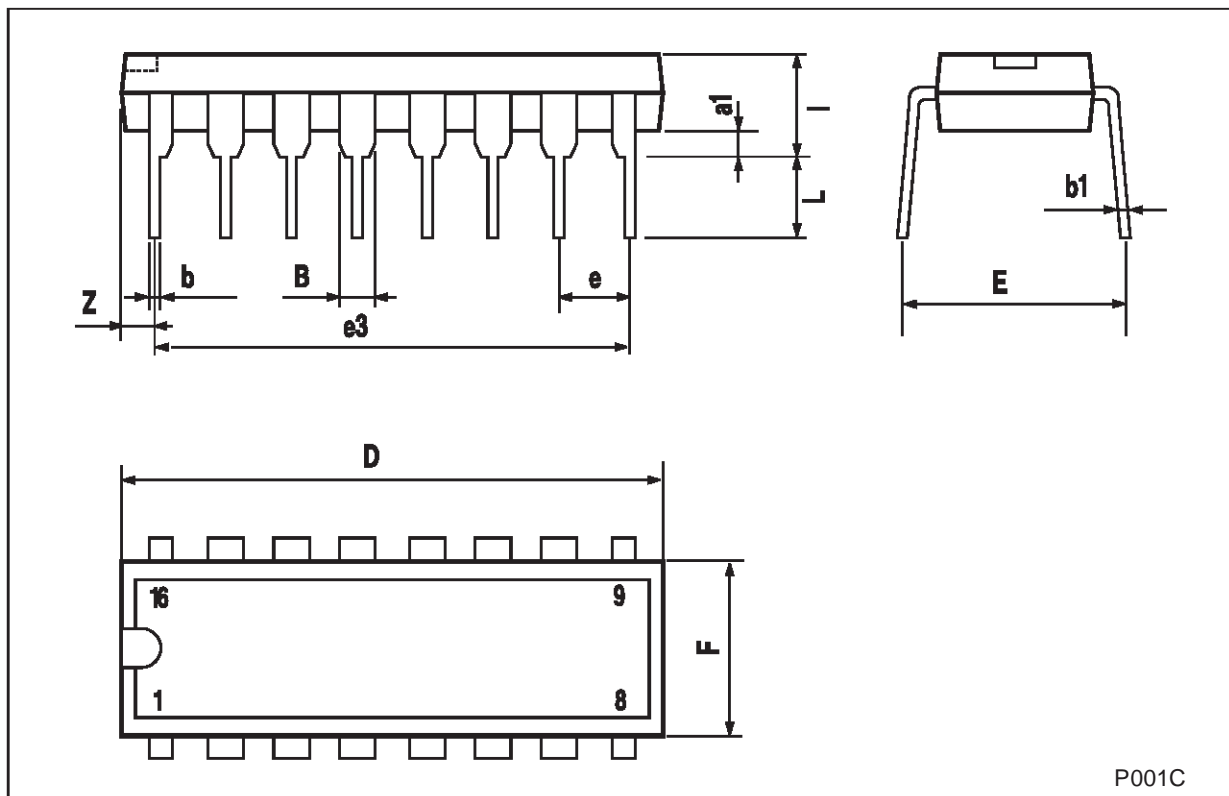

## SO-16 MECHANICAL DATA

DIM.	mm.			inch		
	MIN.	TYP.	MAX.	MIN.	TYP.	MAX.
A			1.75			0.068
a1	0.1		0.2	0.003		0.007
a2			1.65			0.064
b	0.35		0.46	0.013		0.018
b1	0.19		0.25	0.007		0.010
C		0.5			0.019	
c1	45° (typ.)					
D	9.8		10	0.385		0.393
E	5.8		6.2	0.228		0.244
e		1.27			0.050	
e3		8.89			0.350	
F	3.8		4.0	0.149		0.157
G	4.6		5.3	0.181		0.208
L	0.5		1.27	0.019		0.050
M			0.62			0.024
S	8° (max.)					

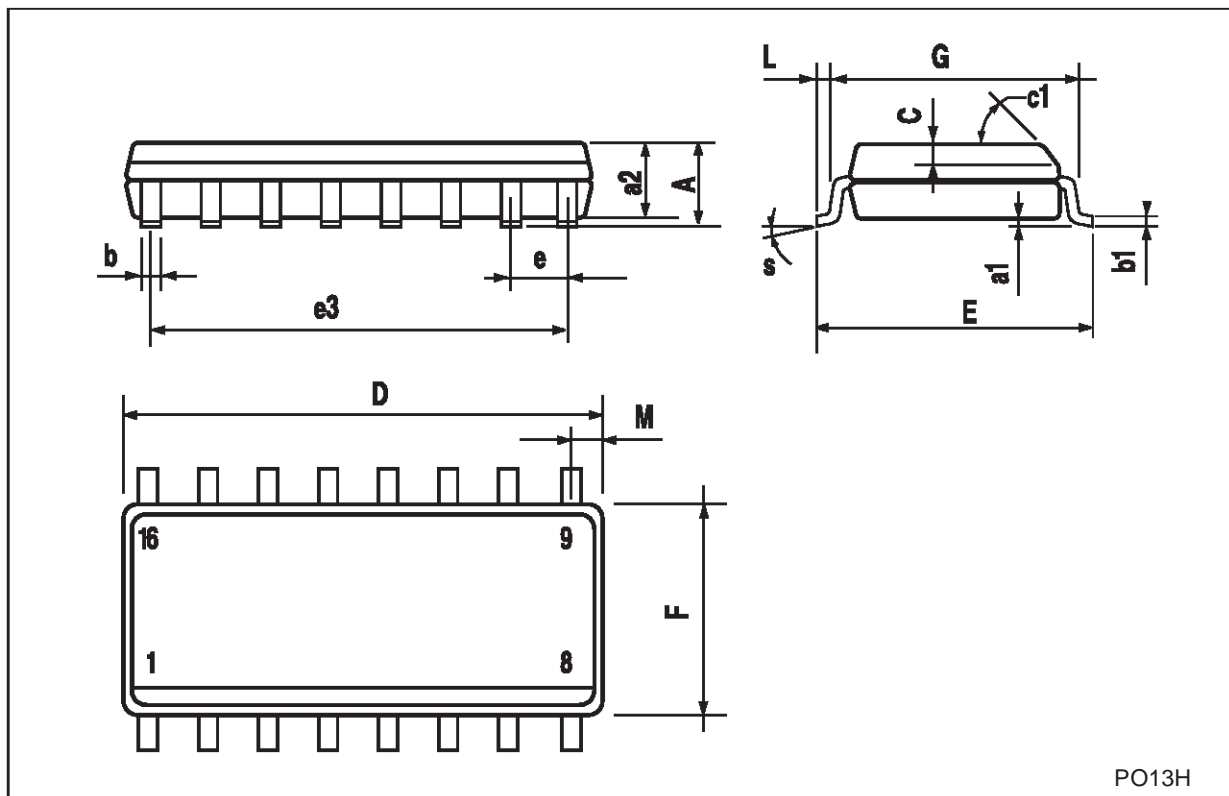

PO13H

## TSSOP16 MECHANICAL DATA

DIM.	mm.			inch		
	MIN.	TYP	MAX.	MIN.	TYP.	MAX.
A			1.2			0.047
A1	0.05		0.15	0.002	0.004	0.006
A2	0.8	1	1.05	0.031	0.039	0.041
b	0.19		0.30	0.007		0.012
c	0.09		0.20	0.004		0.0089
D	4.9	5	5.1	0.193	0.197	0.201
E	6.2	6.4	6.6	0.244	0.252	0.260
E1	4.3	4.4	4.48	0.169	0.173	0.176
e		0.65 BSC			0.0256 BSC	
K	0°		8°	0°		8°
L	0.45	0.60	0.75	0.018	0.024	0.030

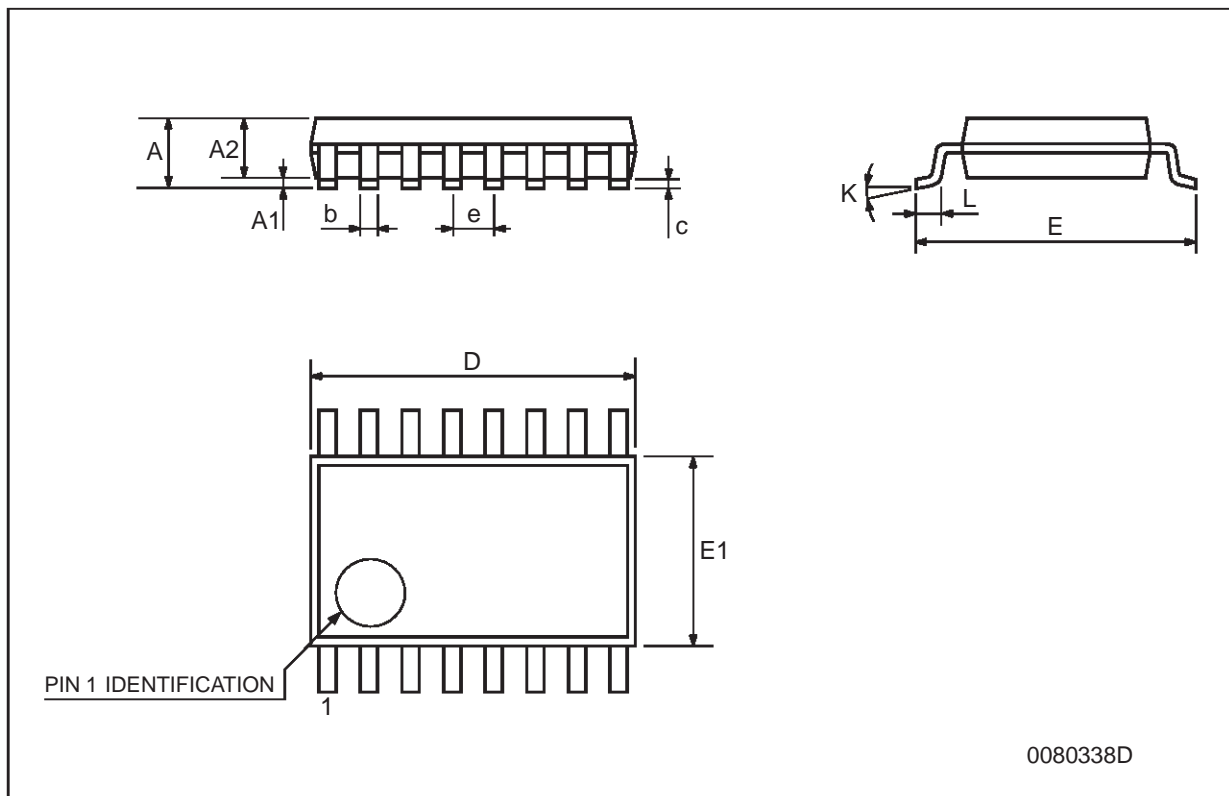

Information furnished is believed to be accurate and reliable. However, STMicroelectronics assumes no responsibility for the consequences of use of such information nor for any infringement of patents or other rights of third parties which may result from its use. No license is granted by implication or otherwise under any patent or patent rights of STMicroelectronics. Specifications mentioned in this publication are subject to change without notice. This publication supersedes and replaces all information previously supplied. STMicroelectronics products are not authorized for use as critical components in life support devices or systems without express written approval of STMicroelectronics.

© The ST logo is a registered trademark of STMicroelectronics

© 2001 STMicroelectronics - Printed in Italy - All Rights Reserved  
STMicroelectronics GROUP OF COMPANIES

Australia - Brazil - China - Finland - France - Germany - Hong Kong - India - Italy - Japan - Malaysia - Malta - Morocco  
Singapore - Spain - Sweden - Switzerland - United Kingdom

© <http://www.st.com>