

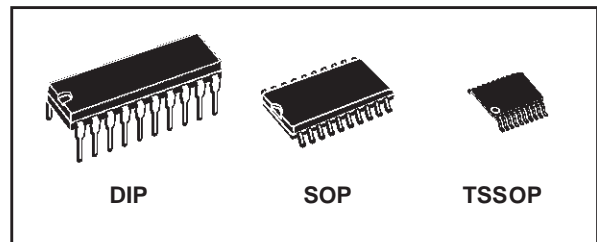

M74HC4351

ANALOG MULTIPLEXER/DEMULTIPLEXER WITH ADDRESS LATCH : SINGLE 8 CHANNEL

- LOGIC LEVEL TRANSLATION TO ENABLE 5V LOGIC SIGNAL TO COMMUNICATE WITH $\pm 5V$ ANALOG SIGNAL
- LOW POWER DISSIPATION:
 $I_{CC} = 4\mu A(\text{MAX.})$ at $T_A = 25^\circ C$
- LOW "ON" RESISTANCE:
 70Ω TYP. ($V_{CC} - V_{EE} = 4.5V$)
 50Ω TYP. ($V_{CC} - V_{EE} = 9V$)
- WIDE ANALOG INPUT VOLTAGE RANGE $\pm 6V$
- LOW CROSSTALK BETWEEN SWITCHES
- FAST SWITCHING
- SINE WAVE DISTORTION:
 0.02% (TYP.) at $V_{CC} - V_{EE} = 9V$
- HIGH NOISE IMMUNITY:
 $V_{NIH} = V_{NIL} = 28\% V_{CC}$ (MIN.)
- PIN AND FUNCTION COMPATIBLE WITH 74 SERIES 4351



ORDER CODES

PACKAGE	TUBE	T & R
DIP	M74HC4351B1R	
SOP	M74HC4351M1R	M74HC4351RM13TR
TSSOP		M74HC4351TTR

DESCRIPTION

The M74HC4351 is an high speed CMOS ANALOG MULTIPLEXER/DEMULTIPLEXER fabricated with silicon gate C²MOS technology. A built-in level shifting is included to allow an input range up to $\pm 6V$ (peak) for an analog signal with digital control signal of 0 to 6V.

V_{EE} supply pin is provided for analog input signals. It has two enable inputs to enable all the switches when high (EN2) or low ($\overline{EN1}$). For operation as a digital multiplexer/demultiplexer, V_{EE} is connected to GND.

The M74HC4351 is a single 8 channel multiplexer/demultiplexer having three binary control inputs A, B and C to select 1 of 8 to be turned on, and connected to the output.

PIN CONNECTION AND IEC LOGIC SYMBOLS

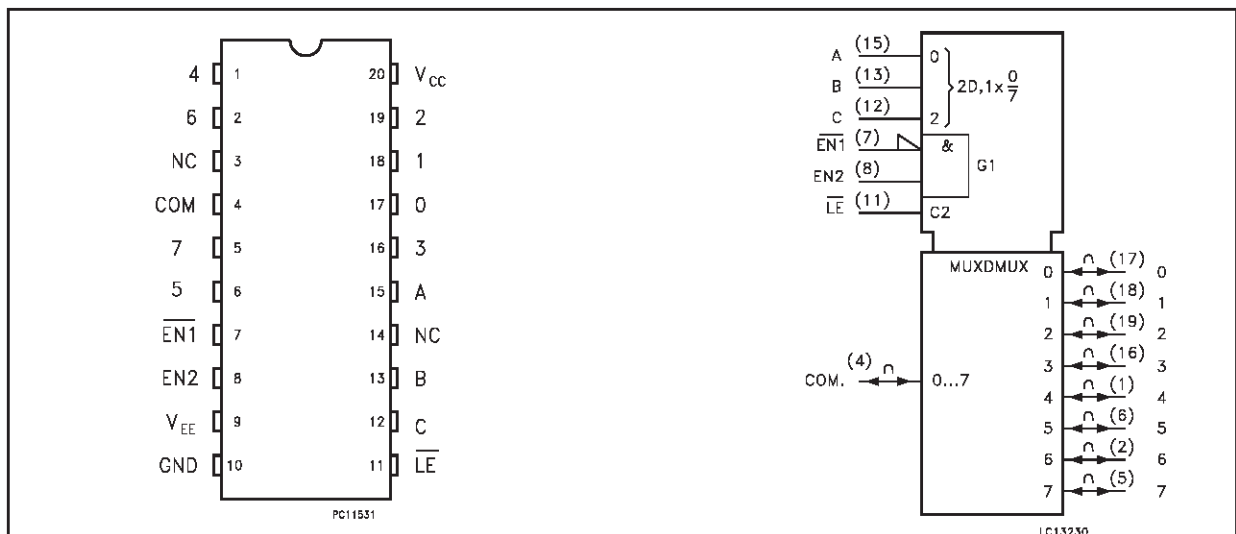

CONTROL INPUT EQUIVALENT CIRCUIT

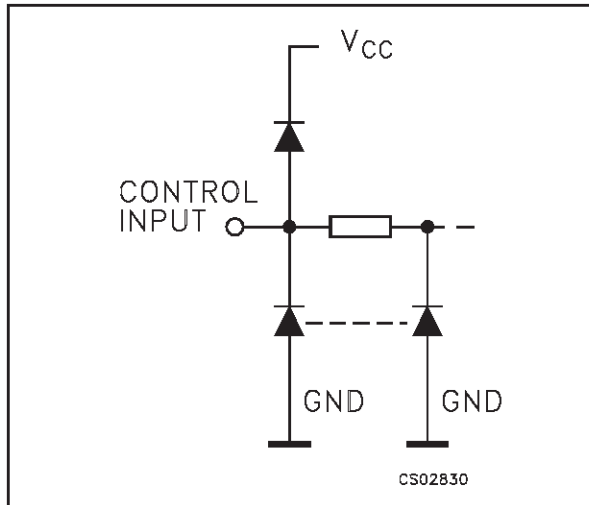

PIN DESCRIPTION

PIN No	SYMBOL	NAME AND FUNCTION
4	COM	Common
3, 14	NC	Not Connected
7	EN1	Enable Input (Active LOW)
8	EN2	Enable Input (Active HIGH)
9	V_{EE}	Negative Supply Voltage
11	LE	Latch Enable Input (Active LOW)
15, 13, 12	A, B, C	Select Inputs
17, 18, 19, 16, 1, 6, 2, 5	0 to 7	Independent Inputs/Outputs
10	GND	Ground (0V)
20	V_{CC}	Positive Supply Voltage

TRUTH TABLE

CONTROL INPUTS					"ON" CHANNEL ($\overline{LE} = H$)**
$\overline{EN1}$	EN2	C	B	A	
L	H	L	L	L	0
L	H	L	L	H	1
L	H	L	H	L	2
L	H	L	H	H	3
L	H	H	L	L	4
L	H	H	L	H	5
L	H	H	H	L	6
L	H	H	H	H	7
H	X	X	X	X	NONE
X	L	X	X	X	NONE

X : Don't Care

** : When latch Enable is low, the Channel Selection is latched and the Channel Address Latch does not change state.

ABSOLUTE MAXIMUM RATINGS

Symbol	Parameter	Value	Unit
V_{CC}	Supply Voltage	-0.5 to +7	V
$V_{CC} - V_{EE}$	Supply Voltage Range	-0.5 to +13	V
V_{IN}	DC Input Voltage	-0.5 to $V_{CC} + 0.5$	V
$V_{I/O}$	DC Switch Input/Output Voltage	$V_{EE} - 0.5$ to $V_{CC} + 0.5$	V
I_{IK}	Input Diode Current	± 20	mA
I_{OK}	I/O Diode Current	± 20	mA
I_{OUT}	DC Output Current	± 25	mA
I_{CC} or I_{GND}	DC V_{CC} or Ground Current	± 50	mA
P_D	Power Dissipation	500(*)	mW
T_{stg}	Storage Temperature	-65 to +150	$^{\circ}C$
T_L	Lead Temperature (10 sec)	300	$^{\circ}C$

Absolute Maximum Ratings are those values beyond which damage to the device may occur. Functional operation under these conditions is not implied

(*) 500mW at 65 $^{\circ}C$; derate to 300mW by 10mW/ $^{\circ}C$ from 65 $^{\circ}C$ to 85 $^{\circ}C$

RECOMMENDED OPERATING CONDITIONS

Symbol	Parameter	Value	Unit	
V_{CC}	Supply Voltage	2 to 12	V	
V_{EE}	Supply Voltage	2 to 12	V	
$V_{CC} - V_{EE}$	Supply Voltage	2 to 12	V	
V_I	Input Voltage	0 to V_{CC}	V	
$V_{I/O}$	Switch I/O Voltage	0 to V_{CC}	V	
T_{op}	Operating Temperature	-55 to 125	°C	
t_r, t_f	Input Rise and Fall Time	$V_{CC} = 2.0V$	0 to 1000	ns
		$V_{CC} = 4.5V$	0 to 500	
		$V_{CC} = 6.0V$	0 to 400	

DC SPECIFICATIONS

Symbol	Parameter	Test Condition			Value						Unit	
		V_{CC} (V)	V_{EE} (V)		$T_A = 25^\circ C$			$-40 \text{ to } 85^\circ C$		$-55 \text{ to } 125^\circ C$		
					Min.	Typ.	Max.	Min.	Max.	Min.		Max.
V_{IHC}	High Level Control Input Voltage	2.0			1.5			1.5		1.5		V
		4.5			3.15			3.15		3.15		
		6.0			4.2			4.2		4.2		
V_{ILC}	Low Level Control Input Voltage	2.0					0.5		0.5		0.5	V
		4.5					1.35		1.35		1.35	
		6.0					1.8		1.8		1.8	
R_{ON}	ON Resistance	4.5	GND	$V_I = V_{IHC} \text{ or } V_{ILC}$ $V_{I/O} = V_{CC} \text{ to } V_{EE}$ $I_{I/O} \leq 2 \text{ mA}$		85	180		225			Ω
		4.5	-4.5			55	120		150			
		6.0	-6.0			50	100		125			
		2.0	GND	$V_I = V_{IHC} \text{ or } V_{ILC}$ $V_{I/O} = V_{CC} \text{ or } V_{EE}$ $I_{I/O} \leq 2 \text{ mA}$		150						
		4.5	GND			70	150		190			
		4.5	-4.5			50	100		125			
6.0	-6.0		45	80		100						
ΔR_{ON}	Difference of ON Resistance between switches	4.5	GND	$V_I = V_{IHC} \text{ or } V_{ILC}$ $V_{I/O} = V_{CC} \text{ to } V_{EE}$ $I_{I/O} \leq 2 \text{ mA}$		10	30		35			Ω
		4.5	-4.5			5	12		15			
		6.0	-6.0			5	10		12			
I_{OFF}	Input/Output Leakage Current (SWITCH OFF)	6.0	-6.0	$V_{OS} = V_{CC} \text{ or } GND$ $V_{IS} = V_{CC} \text{ or } GND$ $V_{IN} = V_{ILC}$			± 100		± 1000		nA	
I_{IZ}	Switch Input Leakage Current (SWITCH ON, OUTPUT OPEN)	6.0	-6.0	$V_{OS} = V_{CC} \text{ or } GND$ $V_{INH} = V_{IHC}$			± 100		± 1000		nA	
I_{IN}	Control Input Current	6.0	GND	$V_{IN} = V_{CC} \text{ or } GND$			± 0.1		± 1		μA	
I_{CC}	Quiescent Supply Current	6.0	GND	$V_{IN} = V_{CC} \text{ or } GND$			4		40		80	μA
		6.0	-6.0				8		80		160	

AC ELECTRICAL CHARACTERISTICS ($C_L = 50$ pF, Input $t_r = t_f = 6$ ns, GND = 0)

Symbol	Parameter	Test Condition			Value						Unit	
		V_{CC} (V)	V_{EE} (V)		$T_A = 25^\circ\text{C}$			-40 to 85°C		-55 to 125°C		
					Min.	Typ.	Max.	Min.	Max.	Min.		Max.
$\Phi_{I/O}$	Phase Difference Between Input and Output	2.0	GND			25	60		75			ns
		4.5	GND			6	12		15			
		6.0	GND			5	10		13			
		4.5	-4.5			4						
t_{PZL} t_{PZH}	Output Enable Time (E1, E2 - O)	2.0	GND	$R_L = 1\text{K}\Omega$		80	200		250		300	ns
		4.5	GND			20	40		50		60	
		6.0	GND			16	34		43		51	
		4.5	-4.5			18						
t_{PZL} t_{PZH}	Output Enable Time (LE -I/O)	2.0	GND	$R_L = 1\text{K}\Omega$		80	225		280		340	ns
		4.5	GND			22	45		56		68	
		6.0	GND			17	38		48		57	
		4.5	-4.5			18						
t_{PZL} t_{PZH}	Output Enable Time (A, B, C - I/O)	2.0	GND	$R_L = 1\text{K}\Omega$		75	225		280		340	ns
		4.5	GND			22	45		56		68	
		6.0	GND			16	38		48		57	
		4.5	-4.5			17						
t_{PLZ} t_{PHZ}	Output Disable Time (E1, E2 - O)	2.0	GND	$R_L = 1\text{K}\Omega$		120	275		344		415	ns
		4.5	GND			38	55		69		83	
		6.0	GND			33	47		59		71	
		4.5	-4.5			30						
t_{PLZ} t_{PHZ}	Output Disable Time (LE -I/O)	2.0	GND	$R_L = 1\text{K}\Omega$		120	275		344		415	ns
		4.5	GND			40	55		69		83	
		6.0	GND			35	47		59		71	
		4.5	-4.5			34						
t_{PLZ} t_{PHZ}	Output Disable Time (A, B, C - I/O)	2.0	GND	$R_L = 1\text{K}\Omega$		120	290		363		433	ns
		4.5	GND			40	58		73		87	
		6.0	GND			35	49		61		74	
		4.5	-4.5			35						
$t_{W(H)}$	Minimum Pulse Width (LE)	2.0	GND			75		95		110	ns	
		4.5	GND			15		19		22		
		6.0	GND			13		16		19		
t_s	Minimum Set-Up Time	2.0	GND			50		60		75	ns	
		4.5	GND			10		12		15		
		6.0	GND			9		11		13		
t_h	Minimum Hold Time	2.0	GND			5		5		5	ns	
		4.5	GND			5		5		5		
		6.0	GND			5		5		5		

CAPACITIVE CHARACTERISTICS

Symbol	Parameter	Test Condition			Value						Unit	
		V _{CC} (V)	V _{EE} (V)		T _A = 25°C			-40 to 85°C		-55 to 125°C		
					Min.	Typ.	Max.	Min.	Max.	Min.		Max.
C _{IN}	Input Capacitance					5	10		10		10	pF
C _{IS}	Common Terminal Capacitance	5.0	-5.0			36	70		70		70	pF
C _{OS}	Switch Terminal Capacitance	5.0	-5.0			7	15		15		15	pF
C _{IOS}	Feed Through Capacitance	5.0	-5.0			0.95	2		2		2	pF
C _{PD}	Power Dissipation Capacitance (note 1)	5.0	GND			23						pF

1) C_{PD} is defined as the value of the IC's internal equivalent capacitance which is calculated from the operating current consumption without load. (Refer to Test Circuit). Average operating current can be obtained by the following equation. $I_{CC(oper)} = C_{PD} \times V_{CC} \times f_{IN} + I_{CC}$

ANALOG SWITCH CHARACTERISTICS (GND = 0V; T_A = 25°C)

Symbol	Parameter	Test Condition			Value	Unit	
		V _{CC} (V)	V _{EE} (V)	V _{IN} (V _{p-p})			
	Sine Wave Distortion (THD)	2.25	-2.25	4	f _{IN} = 1 KHz R _L = 10 KΩ, C _L = 50 pF	0.025	%
		4.5	-4.5	8		0.020	
f _{MAX}	Frequency Response (Switch ON)	4.5	-4.5	Adjust f _{IN} voltage to obtain 0 dBm at V _{OS} . Increase f _{IN} Frequency until dB meter reads -3dB R _L = 50Ω, C _L = 10 pF(*)		200	MHz
	Feed through Attenuation (Switch OFF)	2.25	-2.25	V _{IN} is centered at (V _{CC} - V _{EE}) / 2. Adjust input for 0 dBm R _L = 600Ω, C _L = 50 pF, f _{IN} = 1MHz sine wave		-50	dB
		4.5	-4.5			-50	
		6.0	-6.0			-50	
	Crosstalk Control to Switch	2.25	-2.25	t _r = t _f = 6ns R _L = 600Ω, C _L = 50 pF f _{IN} = 1MHz square wave		110	mV
		4.5	-4.5			225	
		6.0	-6.0			310	
	Crosstalk (Between Any Switches)	2.25	-2.25	Adjust V _{IN} to Obtain 0 dBm at input R _L = 600Ω, C _L = 50 pF, f _{IN} = 1MHz sine wave		-50	dB
		4.5	-4.5			-50	
		6.0	-6.0			-50	

(*) : Input COMMON Terminal, and measured at SWITCH Terminal.

NOTE : These Characteristics are determined by design of device.

SWITCHING CHARACTERISTICS TEST CIRCUIT

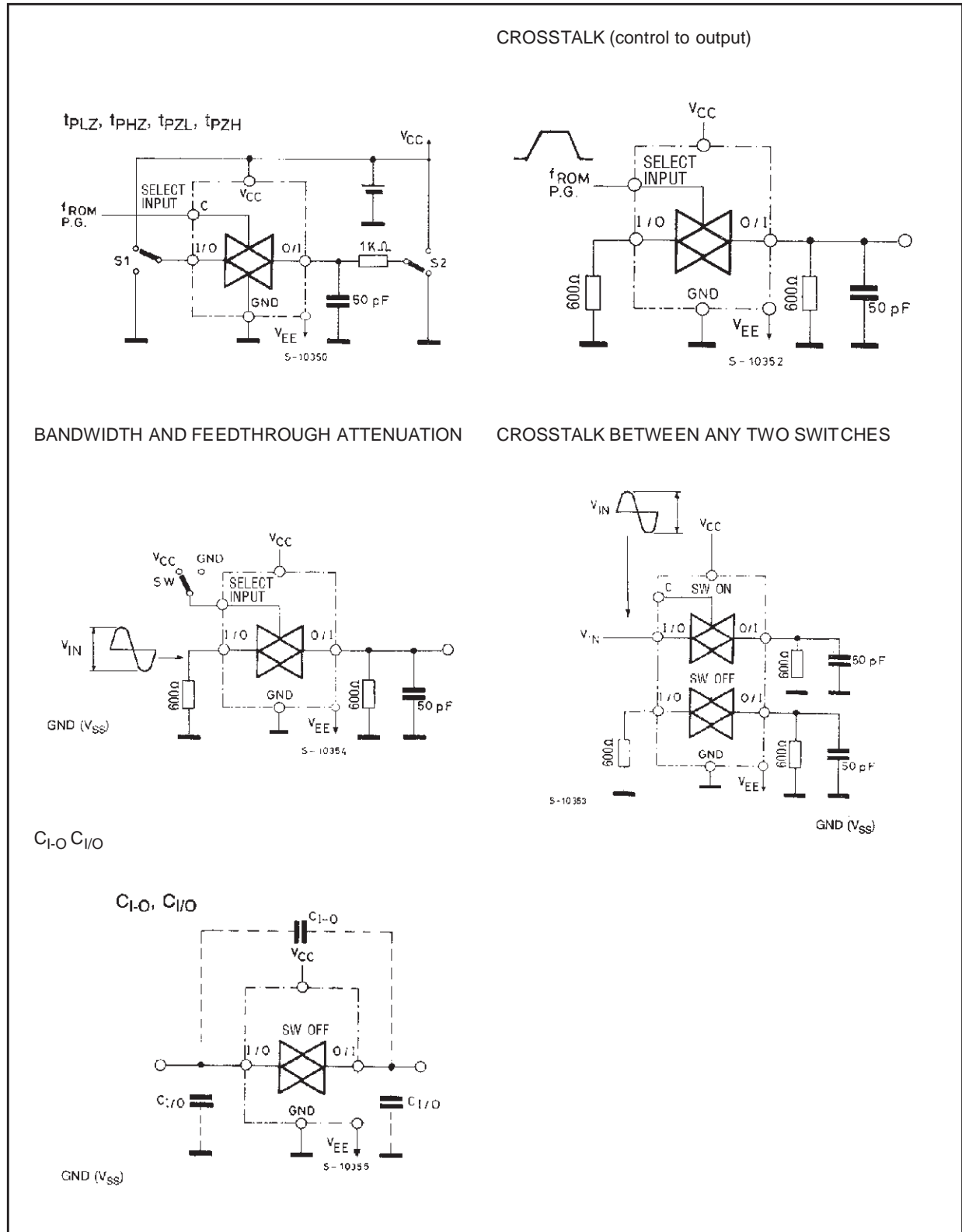

WAVEFORM 1 : OUTPUT ENABLE AND DISABLE TIME (f=1MHz; 50% duty cycle)

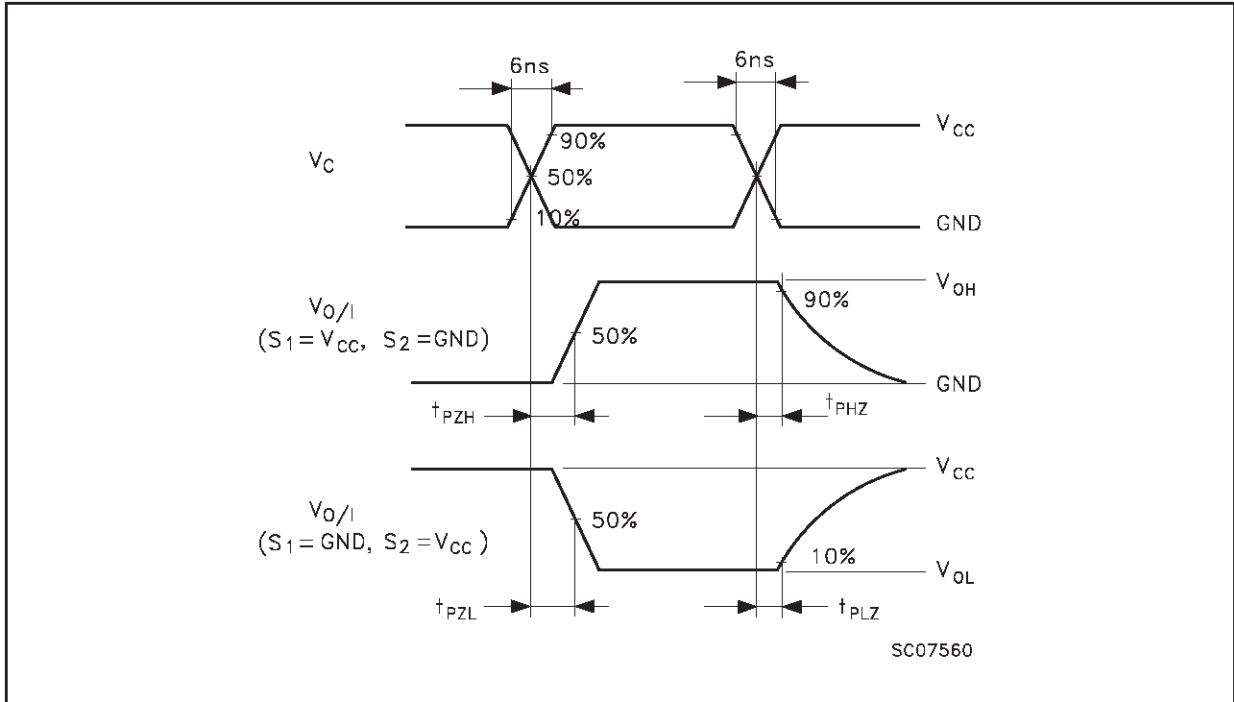

WAVEFORM 2 : MINIMUM PULSE WIDTH, SETUP AND HOLD TIME (f=1MHz; 50% duty cycle)

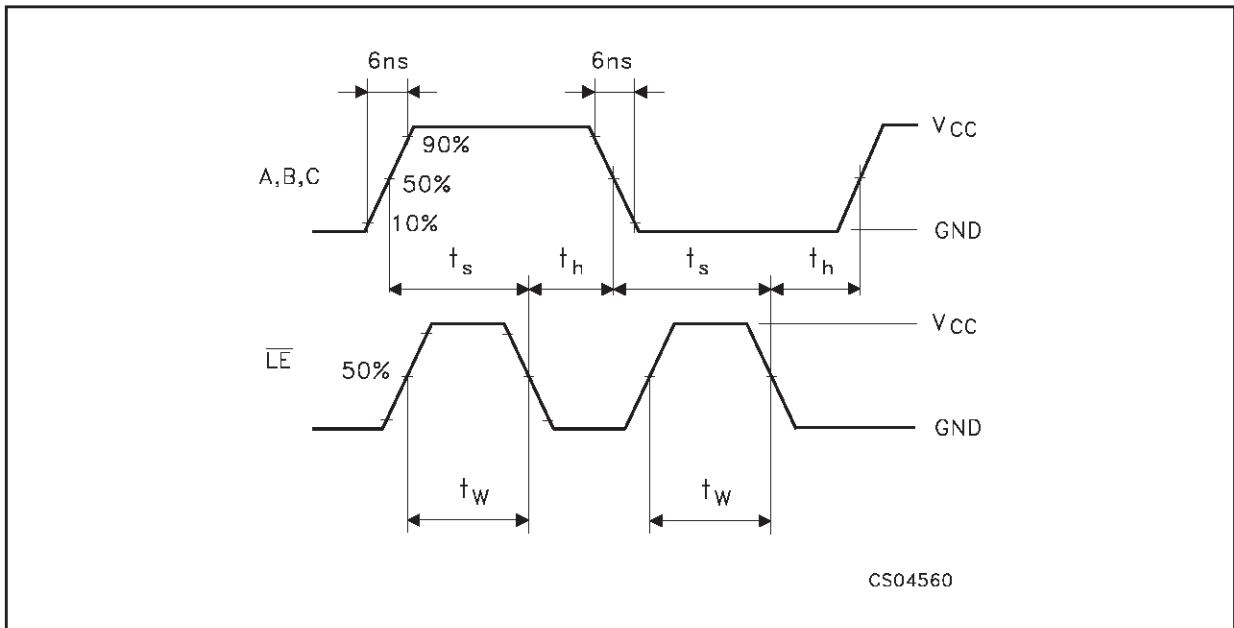

CHANNEL RESISTANCE (R_{ON})

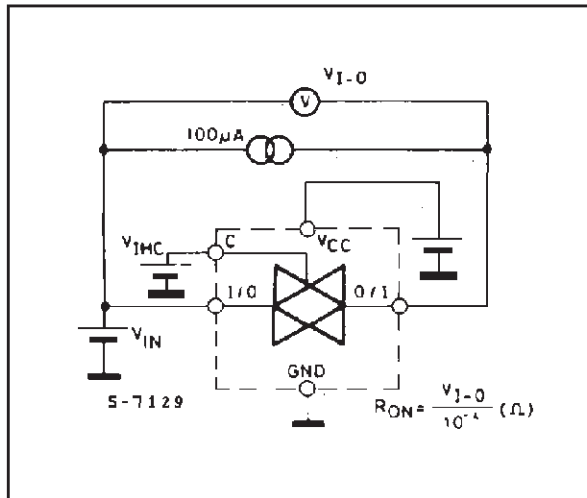

I_{CC} (Opr.)

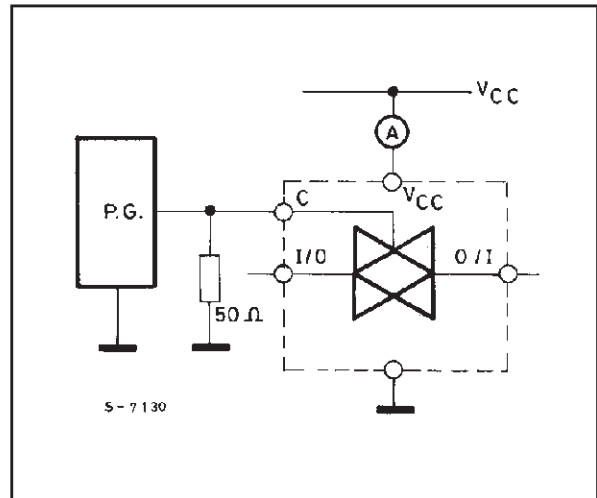

Plastic DIP-20 (0.25) MECHANICAL DATA

DIM.	mm.			inch		
	MIN.	TYP.	MAX.	MIN.	TYP.	MAX.
a1	0.254			0.010		
B	1.39		1.65	0.055		0.065
b		0.45			0.018	
b1		0.25			0.010	
D			25.4			1.000
E		8.5			0.335	
e		2.54			0.100	
e3		22.86			0.900	
F			7.1			0.280
I			3.93			0.155
L		3.3			0.130	
Z			1.34			0.053

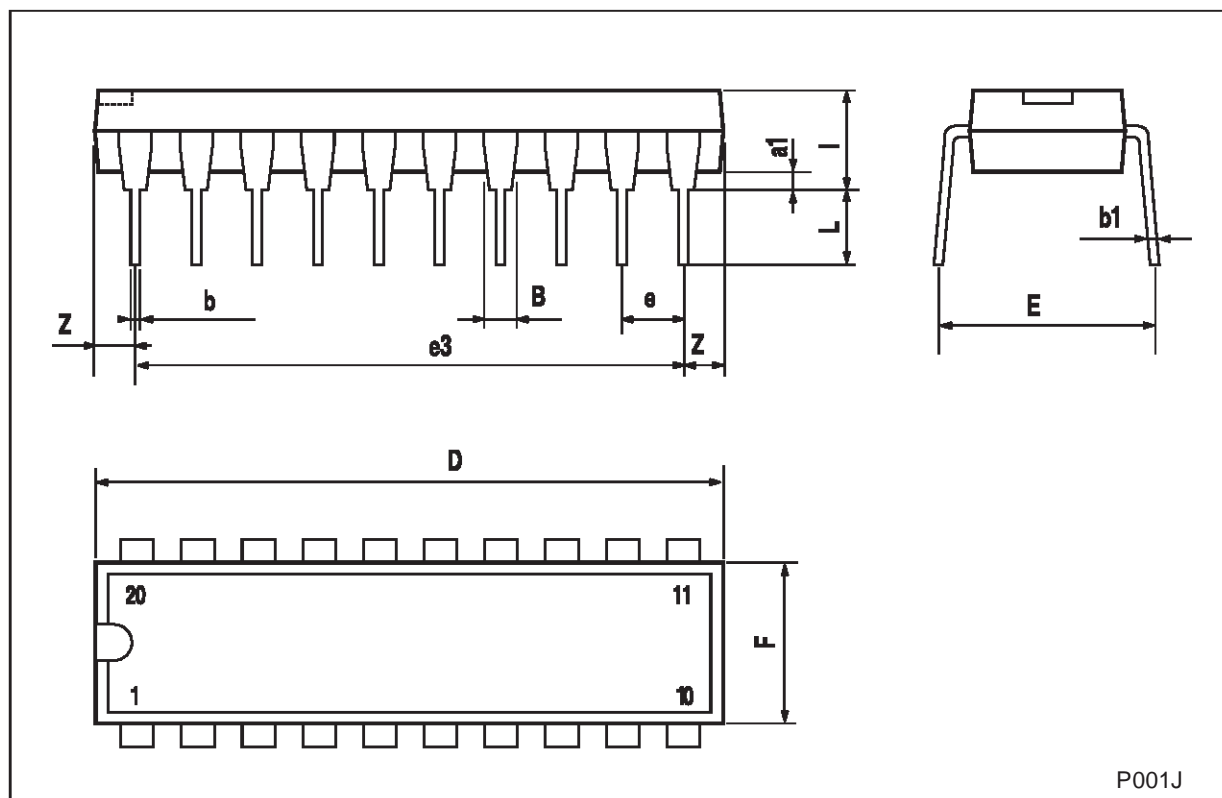

SO-20 MECHANICAL DATA

DIM.	mm.			inch		
	MIN.	TYP.	MAX.	MIN.	TYP.	MAX.
A			2.65			0.104
a1	0.1		0.2	0.004		0.008
a2			2.45			0.096
b	0.35		0.49	0.014		0.019
b1	0.23		0.32	0.009		0.012
C		0.5			0.020	
c1	45° (typ.)					
D	12.60		13.00	0.496		0.512
E	10.00		10.65	0.393		0.419
e		1.27			0.050	
e3		11.43			0.450	
F	7.40		7.60	0.291		0.300
L	0.50		1.27	0.020		0.050
M			0.75			0.029
S	8° (max.)					

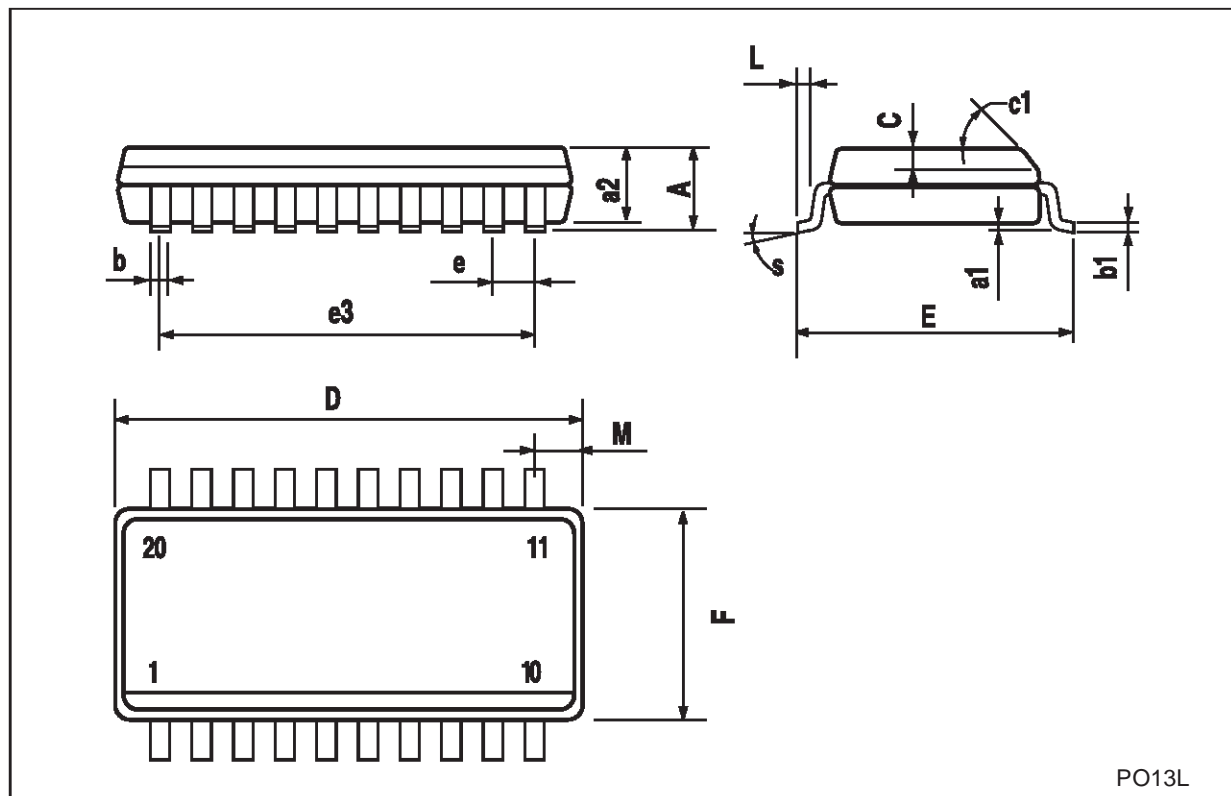

PO13L

TSSOP20 MECHANICAL DATA

DIM.	mm.			inch		
	MIN.	TYP	MAX.	MIN.	TYP.	MAX.
A			1.2			0.047
A1	0.05		0.15	0.002	0.004	0.006
A2	0.8	1	1.05	0.031	0.039	0.041
b	0.19		0.30	0.007		0.012
c	0.09		0.20	0.004		0.0089
D	6.4	6.5	6.6	0.252	0.256	0.260
E	6.2	6.4	6.6	0.244	0.252	0.260
E1	4.3	4.4	4.48	0.169	0.173	0.176
e		0.65 BSC			0.0256 BSC	
K	0°		8°	0°		8°
L	0.45	0.60	0.75	0.018	0.024	0.030

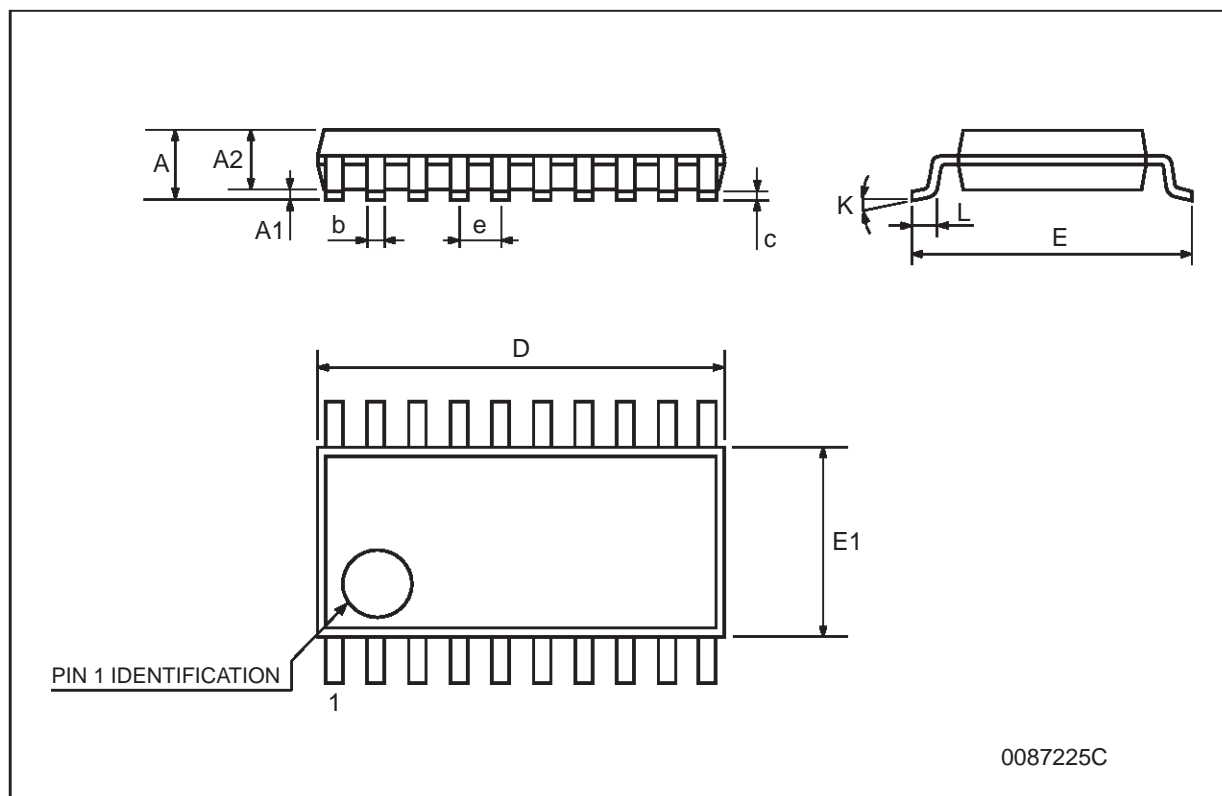

Information furnished is believed to be accurate and reliable. However, STMicroelectronics assumes no responsibility for the consequences of use of such information nor for any infringement of patents or other rights of third parties which may result from its use. No license is granted by implication or otherwise under any patent or patent rights of STMicroelectronics. Specifications mentioned in this publication are subject to change without notice. This publication supersedes and replaces all information previously supplied. STMicroelectronics products are not authorized for use as critical components in life support devices or systems without express written approval of STMicroelectronics.

© The ST logo is a registered trademark of STMicroelectronics

© 2001 STMicroelectronics - Printed in Italy - All Rights Reserved
STMicroelectronics GROUP OF COMPANIES

Australia - Brazil - China - Finland - France - Germany - Hong Kong - India - Italy - Japan - Malaysia - Malta - Morocco
Singapore - Spain - Sweden - Switzerland - United Kingdom

© <http://www.st.com>