

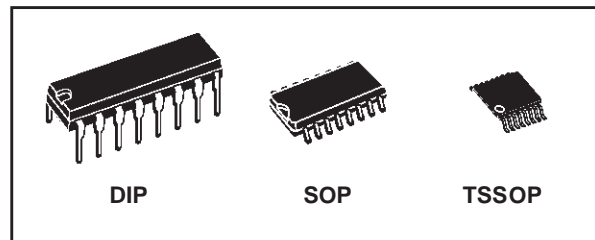

M74HC590

8 BINARY COUNTER REGISTER WITH 3 STATE OUTPUT

- HIGH SPEED:
 $f_{MAX} = 61 \text{ MHz (TYP.) at } V_{CC} = 6V$
- LOW POWER DISSIPATION:
 $I_{CC} = 4\mu\text{A (MAX.) at } T_A = 25^\circ\text{C}$
- HIGH NOISE IMMUNITY:
 $V_{NIH} = V_{NIL} = 28\% V_{CC} \text{ (MIN.)}$
- SYMMETRICAL OUTPUT IMPEDANCE:
 $|I_{OH}| = I_{OL} = 6\text{mA (MIN) for QA} \sim \text{QH OUTPUT}$
 $|I_{OH}| = I_{OL} = 4\text{mA (MIN) for RCO OUTPUT}$
- BALANCED PROPAGATION DELAYS:
 $t_{PLH} \cong t_{PHL}$
- WIDE OPERATING VOLTAGE RANGE:
 $V_{CC} \text{ (OPR)} = 2V \text{ to } 6V$
- PIN AND FUNCTION COMPATIBLE WITH 74 SERIES 590



ORDER CODES

PACKAGE	TUBE	T & R
DIP	M74HC590B1R	
SOP	M74HC590M1R	M74HC590RM13TR
TSSOP		M74HC590TTR

DESCRIPTION

The M74HC590 is an high speed CMOS 8-BIT BINARY COUNTER REGISTER (3 STATE) fabricated with silicon gate C²MOS technology. This device contains an 8-bit binary counter that feeds an 8-bit storage register. The storage register has parallel outputs. Separate clocks are provided for both the binary counter and storage register. The binary counter features a direct clear input CCLR and a count enable input CCKEN. For

cascading, a ripple carry output $\overline{\text{RCO}}$ is provided. Expansion is easily accomplished by tying RCO of the first stage to CCKEN of the second stage, etc. Both the counter and register clocks are positive edge triggered. If the user wishes to connect both clocks together, the counter state will always be one count ahead of the register. Internal circuitry prevents clocking from the clock enable. All inputs are equipped with protection circuits against static discharge and transient excess voltage.

PIN CONNECTION AND IEC LOGIC SYMBOLS

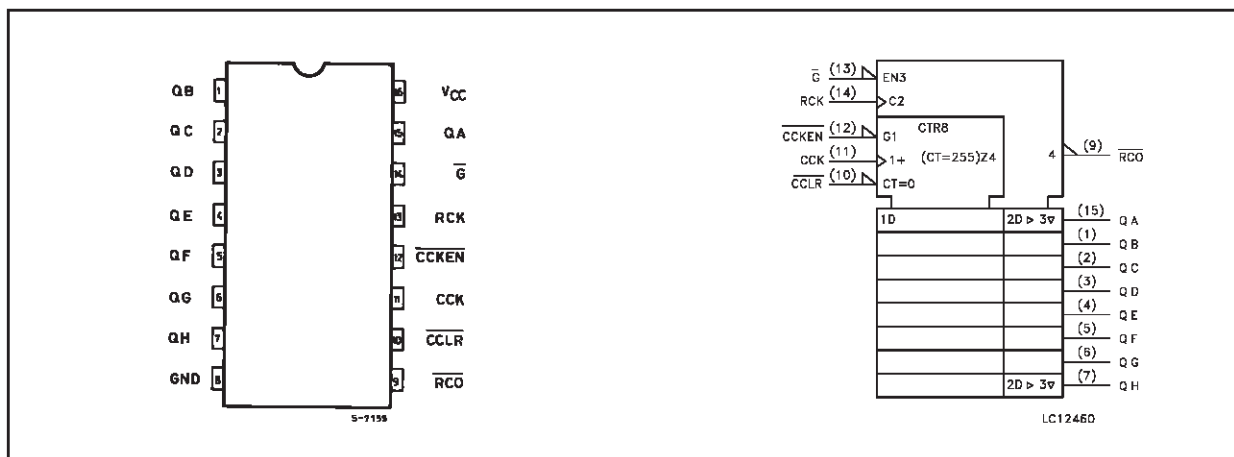

INPUT AND OUTPUT EQUIVALENT CIRCUIT

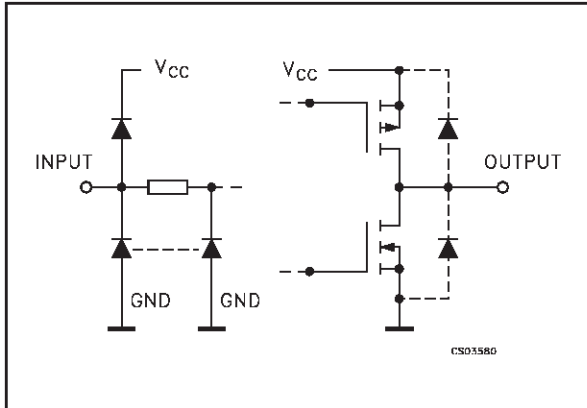

PIN DESCRIPTION

PIN No	SYMBOL	NAME AND FUNCTION
1, 2, 3, 4, 5, 6, 7, 15	QA to QH	Outputs
11	CCK	Counter Clock Input
12	CCKEN	Counter Clock Enable Input
13	RCK	Register Clock Input
9	RCO	Ripple Carry Output
14	G	Output Enable Input
10	CCLR	Counter Clear Input
8	GND	Ground (0V)
16	V _{CC}	Positive Supply Voltage

TRUTH TABLE

INPUTS					OUTPUT
\overline{G}	RCK	\overline{CCLR}	\overline{CCKEN}	CCK	
H	X	X	X	X	Q OUTPUTS DISABLE
L	X	X	X	X	Q OUTPUTS ENABLE
X		X	X	X	COUNTER DATA IS STORED INTO REGISTER
X		X	X	X	REGISTER STAGE IS NOT CHANGED
X	X	L	X	X	COUNTER CLEAR
X	X	H	L		ADVANCE ONE COUNT
X	X	H	L		NO COUNT
X	X	H	H	X	NO COUNT

X: Don't Care

RCO = QA'·QB'·QC'·QD'·QE'·QF'·QG'·QH' (QA' to QH' : INTERNAL OUTPUTS OF THE COUNTER)

LOGIC DIAGRAM

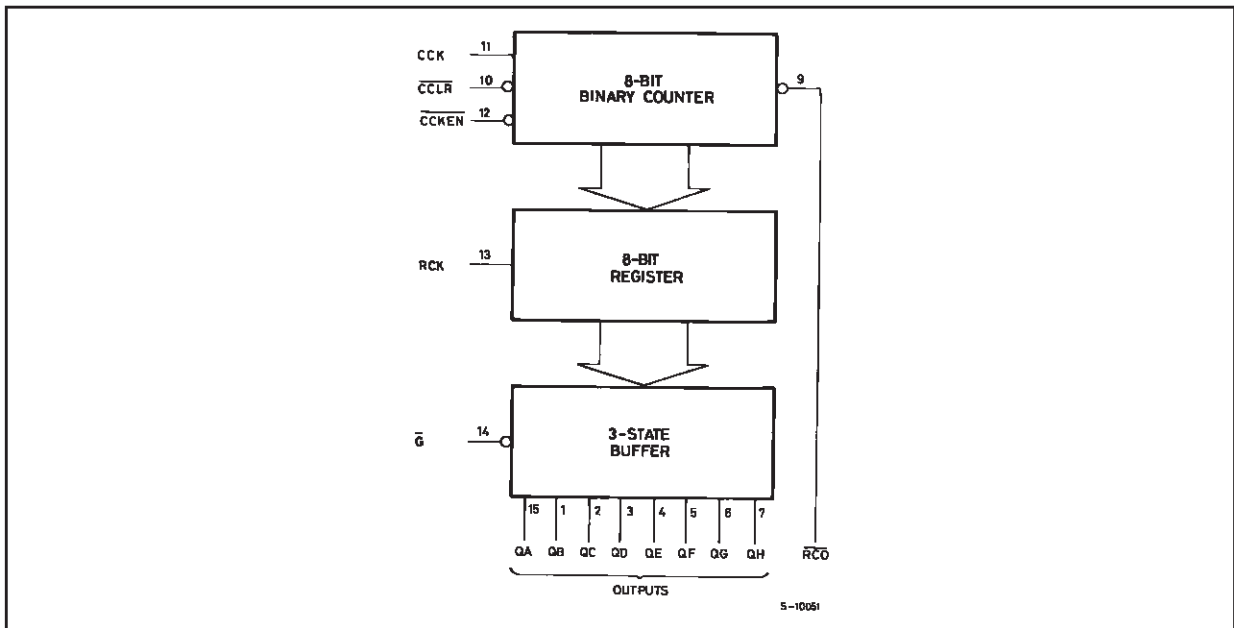

LOGIC DIAGRAM

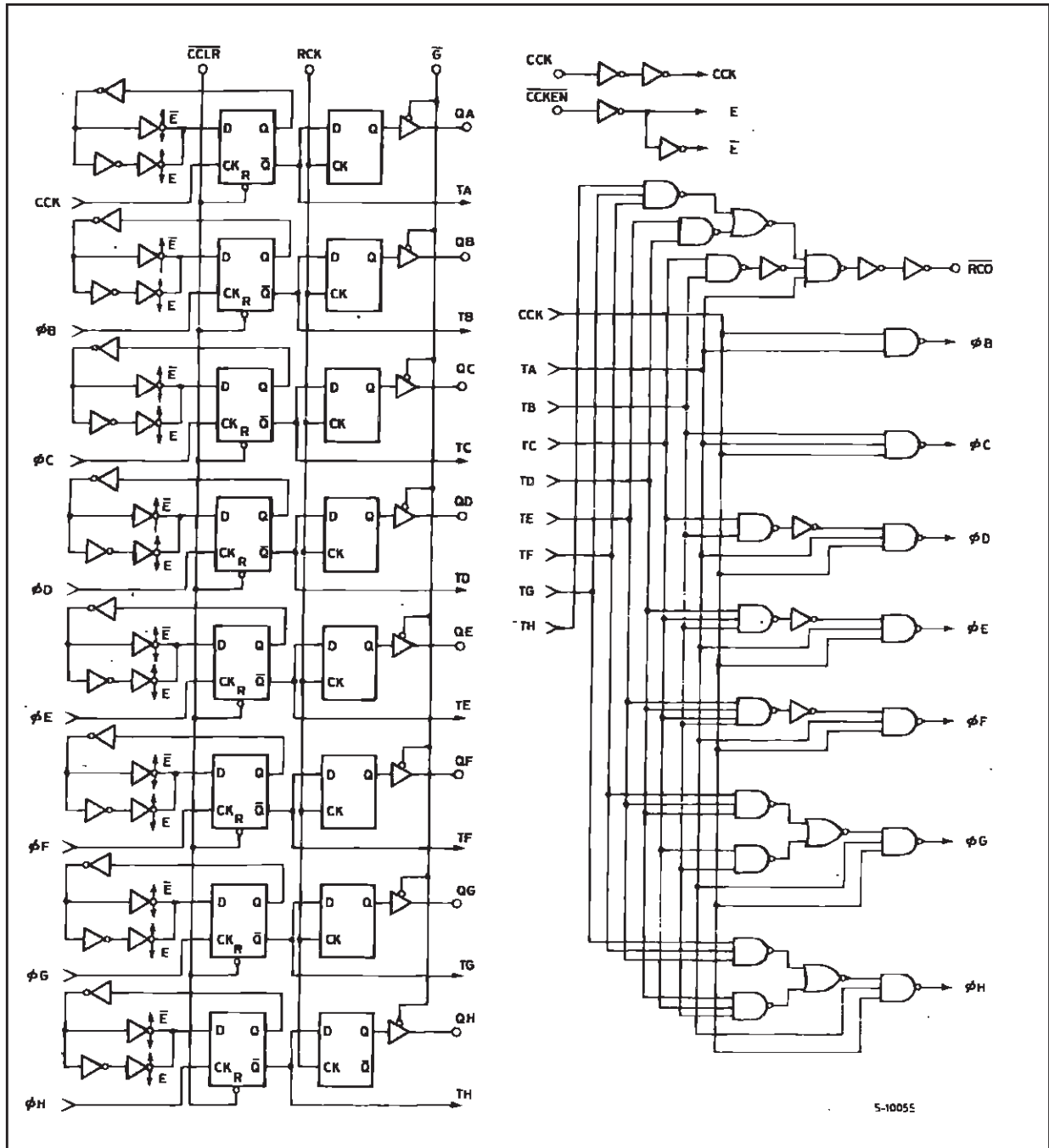

This logic diagram has not been used to estimate propagation delays

TIMING CHART

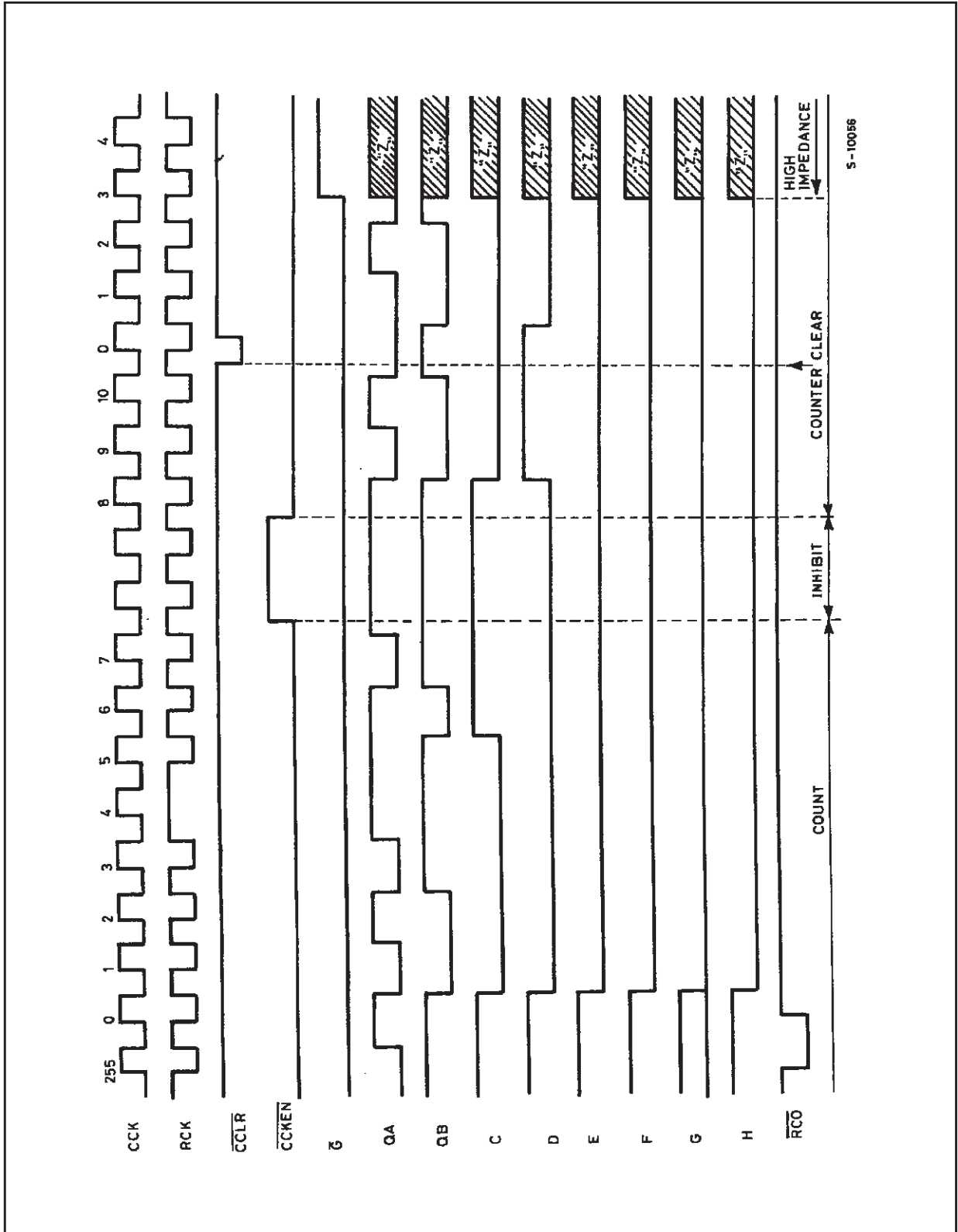

ABSOLUTE MAXIMUM RATINGS

Symbol	Parameter	Value	Unit
V_{CC}	Supply Voltage	-0.5 to +7	V
V_I	DC Input Voltage	-0.5 to $V_{CC} + 0.5$	V
V_O	DC Output Voltage	-0.5 to $V_{CC} + 0.5$	V
I_{IK}	DC Input Diode Current	± 20	mA
I_{OK}	DC Output Diode Current	± 20	mA
I_O	DC Output Source Sink Current per Output PIN (RCO) (QA - QH)	± 25 ± 35	mA
I_{CC} or I_{GND}	DC V_{CC} or Ground Current	± 70	mA
P_D	Power Dissipation	500(*)	mW
T_{stg}	Storage Temperature	-65 to +150	°C
T_L	Lead Temperature (10 sec)	300	°C

Absolute Maximum Ratings are those values beyond which damage to the device may occur. Functional operation under these conditions is not implied

(*) 500mW at 65 °C; derate to 300mW by 10mW/°C from 65°C to 85°C

RECOMMENDED OPERATING CONDITIONS

Symbol	Parameter	Value	Unit	
V_{CC}	Supply Voltage	2 to 6	V	
V_I	Input Voltage	0 to V_{CC}	V	
V_O	Output Voltage	0 to V_{CC}	V	
T_{op}	Operating Temperature	-55 to 125	°C	
t_r, t_f	Input Rise and Fall Time	$V_{CC} = 2.0V$	0 to 1000	ns
		$V_{CC} = 4.5V$	0 to 500	ns
		$V_{CC} = 6.0V$	0 to 400	ns

DC SPECIFICATIONS

Symbol	Parameter	Test Condition		Value						Unit	
		V _{CC} (V)		T _A = 25°C			-40 to 85°C		-55 to 125°C		
				Min.	Typ.	Max.	Min.	Max.	Min.		Max.
V _{IH}	High Level Input Voltage	2.0		1.5			1.5		1.5		V
		4.5		3.15			3.15		3.15		
		6.0		4.2			4.2		4.2		
V _{IL}	Low Level Input Voltage	2.0				0.5		0.5		0.5	V
		4.5				1.35		1.35		1.35	
		6.0				1.8		1.8		1.8	
V _{OH}	High Level Output Voltage (for RCO Output)	2.0	I _O =-20 μA	1.9	2.0		1.9		1.9		V
		4.5	I _O =-20 μA	4.4	4.5		4.4		4.4		
		6.0	I _O =-20 μA	5.9	6.0		5.9		5.9		
		4.5	I _O =-4.0 mA	4.18	4.31		4.13		4.10		
		6.0	I _O =-5.2 mA	5.68	5.8		5.63		5.60		
V _{OH}	High Level Output Voltage (for QA to QH Outputs)	2.0	I _O =-20 μA	1.9	2.0		1.9		1.9		V
		4.5	I _O =-20 μA	4.4	4.5		4.4		4.4		
		6.0	I _O =-20 μA	5.9	6.0		5.9		5.9		
		4.5	I _O =-6.0 mA	4.18	4.31		4.13		4.10		
		6.0	I _O =-7.8 mA	5.68	5.8		5.63		5.60		
V _{OL}	Low Level Output Voltage (for RCO Output)	2.0	I _O =20 μA		0.0	0.1		0.1		0.1	V
		4.5	I _O =20 μA		0.0	0.1		0.1		0.1	
		6.0	I _O =20 μA		0.0	0.1		0.1		0.1	
		4.5	I _O =4.0 mA		0.17	0.26		0.33		0.40	
		6.0	I _O =5.2 mA		0.18	0.26		0.33		0.40	
V _{OL}	Low Level Output Voltage (for QA to QH Outputs)	2.0	I _O =20 μA		0.0	0.1		0.1		0.1	V
		4.5	I _O =20 μA		0.0	0.1		0.1		0.1	
		6.0	I _O =20 μA		0.0	0.1		0.1		0.1	
		4.5	I _O =6.0 mA		0.17	0.26		0.33		0.40	
		6.0	I _O =7.8 mA		0.18	0.26		0.33		0.40	
I _I	Input Leakage Current	6.0	V _I = V _{CC} or GND			± 0.1		± 1		± 1	μA
I _{OZ}	High Impedance Output Leakage Current	6.0	V _I = V _{IH} or V _{IL} V _O = V _{CC} or GND			± 0.5		± 5		± 10	μA
I _{CC}	Quiescent Supply Current	6.0	V _I = V _{CC} or GND			4		40		80	μA

AC ELECTRICAL CHARACTERISTICS ($C_L = 50 \text{ pF}$, Input $t_r = t_f = 6 \text{ ns}$)

Symbol	Parameter	Test Condition			Value						Unit	
		V_{CC} (V)	C_L (pF)		$T_A = 25^\circ\text{C}$			$-40 \text{ to } 85^\circ\text{C}$		$-55 \text{ to } 125^\circ\text{C}$		
					Min.	Typ.	Max.	Min.	Max.	Min.		Max.
t_{TLH} t_{THL}	Output Transition Time	2.0	50			25	60		75		90	ns
		4.5			7	12		15		18		
		6.0			6	10		13		15		
t_{TLH} t_{THL}	Output Transition Time (RCO)	2.0	50			30	75		95		115	ns
		4.5			8	15		19		23		
		6.0			7	13		16		20		
t_{PLH} t_{PHL}	Propagation Delay Time (CCK - $\overline{\text{RCO}}$)	2.0	50			56	165		205		250	ns
		4.5			19	33		41		50		
		6.0			16	28		35		43		
t_{PLH}	Propagation Delay Time (CCLR - $\overline{\text{RCO}}$)	2.0	50			53	175		220		265	ns
		4.5			21	35		44		53		
		6.0			18	30		37		45		
t_{PLH} t_{PHL}	Propagation Delay Time (RCK - Q)	2.0	50			48	145		180		220	ns
		4.5			17	29		36		44		
		6.0			14	25		31		37		
		2.0	150			60	185		230		280	ns
		4.5			21	37		46		56		
		6.0			18	31		39		48		
t_{PZL} t_{PZH}	High Impedance Output Enable Time	2.0	50	$R_L = 1 \text{ K}\Omega$		39	105		130		160	ns
		4.5				13	21		26		32	
		6.0				11	18		22		27	
		2.0	150	$R_L = 1 \text{ K}\Omega$		51	135		170		205	ns
		4.5				17	27		34		41	
		6.0				14	23		29		35	
t_{PLZ} t_{PHZ}	High Impedance Output Disable Time	2.0	50	$R_L = 1 \text{ K}\Omega$		28	105		130		160	ns
		4.5				14	21		26		32	
		6.0				12	18		22		27	
f_{MAX}	Maximum Clock Frequency	2.0	50		6.6	13		5.2		4.4	MHz	
		4.5			33	52		26		22		
		6.0			39	61		31		26		
$t_{W(L)}$ $t_{W(H)}$	Minimum Pulse Width (CCK, RCK)	2.0	50			36	100		125		145	ns
		4.5			9	20		25		29		
		6.0			8	17		21		25		
$t_{W(L)}$	Minimum Pulse Width (CCLR)	2.0	50			32	75		95		110	ns
		4.5			8	15		19		22		
		6.0			7	13		16		19		
t_s	Minimum Set-up Time (CCKEN - CCK)	2.0	50			44	100		125		150	ns
		4.5			11	20		25		30		
		6.0			9	17		21		26		
$t_{s(H)}$	Minimum Set-up Time (CCK - RCK)	2.0	50			76	175		220		255	ns
		4.5			19	35		44		51		
		6.0			16	30		37		43		
t_h	Minimum Hold Time	2.0	50				0		0		0	ns
		4.5				0		0		0		
		6.0				0		0		0		

M74HC590

Symbol	Parameter	Test Condition			Value						Unit	
		V _{CC} (V)	C _L (pF)		T _A = 25°C			-40 to 85°C		-55 to 125°C		
					Min.	Typ.	Max.	Min.	Max.	Min.		Max.
t _{REM}	Minimum Removal Time (CCLR)	2.0	50			28	75		95		110	ns
		4.5				7	15		19		22	
		6.0				6	13		16		19	

CAPACITIVE CHARACTERISTICS

Symbol	Parameter	Test Condition			Value						Unit	
		V _{CC} (V)			T _A = 25°C			-40 to 85°C		-55 to 125°C		
					Min.	Typ.	Max.	Min.	Max.	Min.		Max.
C _{IN}	Input Capacitance					5	10		10		10	pF
C _{PD}	Power Dissipation Capacitance (note 1)					40						pF

1) C_{PD} is defined as the value of the IC's internal equivalent capacitance which is calculated from the operating current consumption without load. (Refer to Test Circuit). Average operating current can be obtained by the following equation. $I_{CC(opr)} = C_{PD} \times V_{CC} \times f_{IN} + I_{CC}$

TEST CIRCUIT

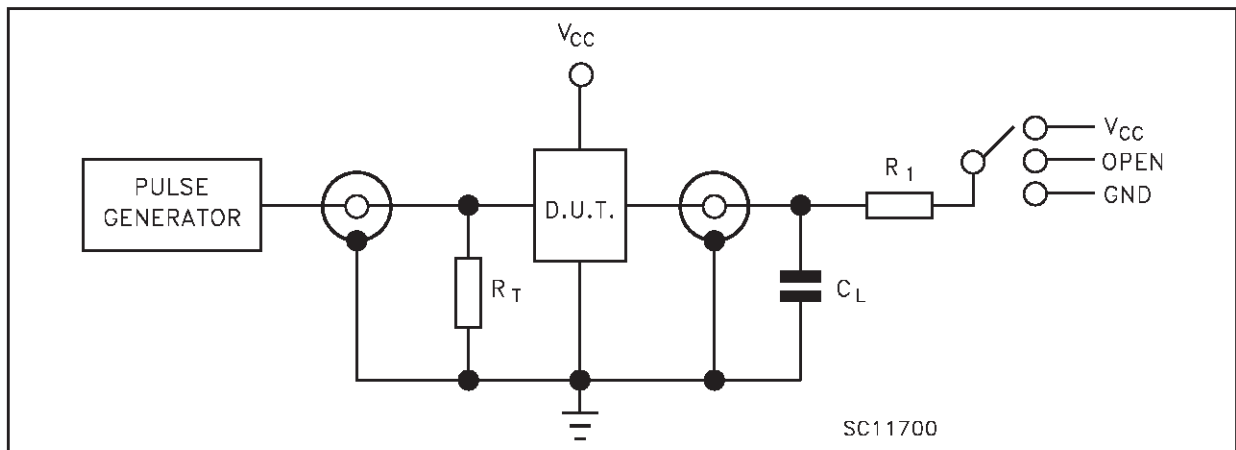

TEST	SWITCH
t _{PLH} , t _{PHL}	Open
t _{PZL} , t _{PLZ}	V _{CC}
t _{PZH} , t _{PHZ}	GND

C_L = 50pF/150pF or equivalent (includes jig and probe capacitance)

R₁ = 1KΩ or equivalent

R_T = Z_{OUT} of pulse generator (typically 50Ω)

WAVEFORM 1 : PROPAGATION DELAY, MINIMUM PULSE WIDTH (f=1MHz; 50% duty cycle)

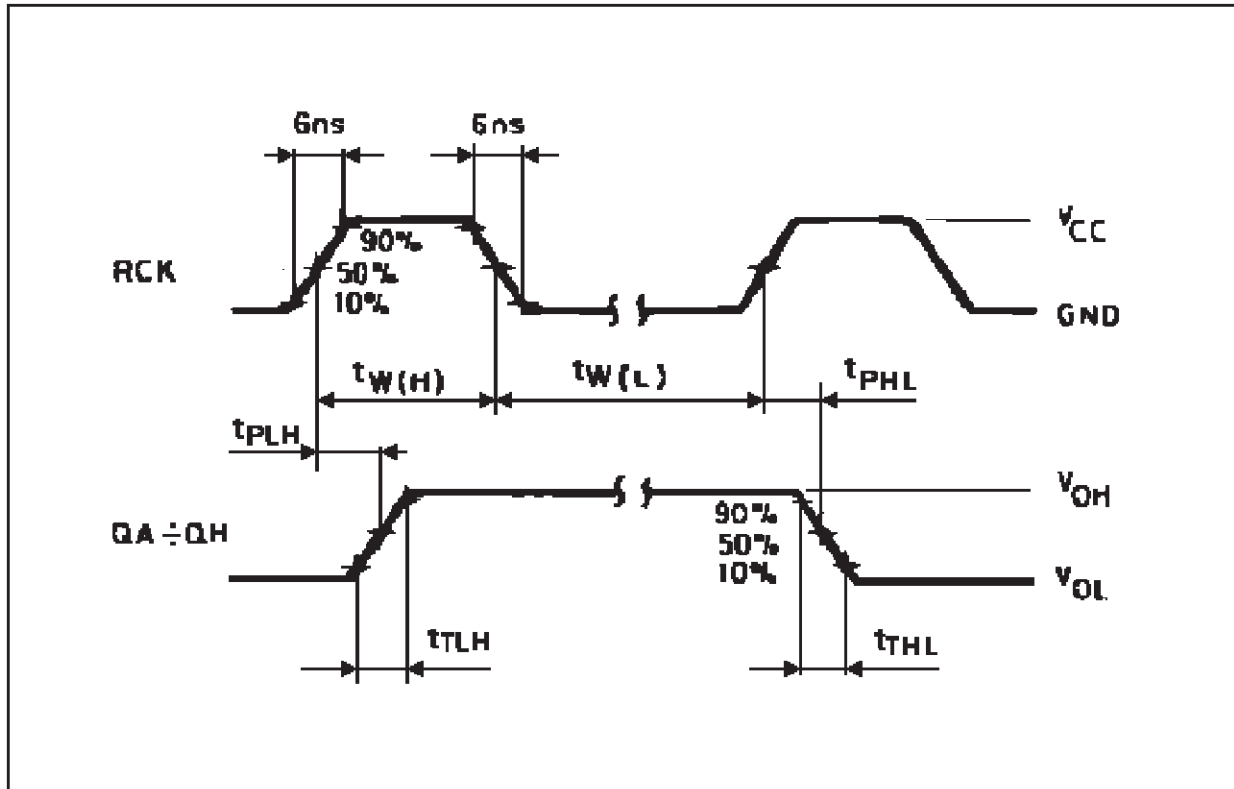

WAVEFORM 2 : MINIMUM SETUP AND HOLD TIME (f=1MHz; 50% duty cycle)

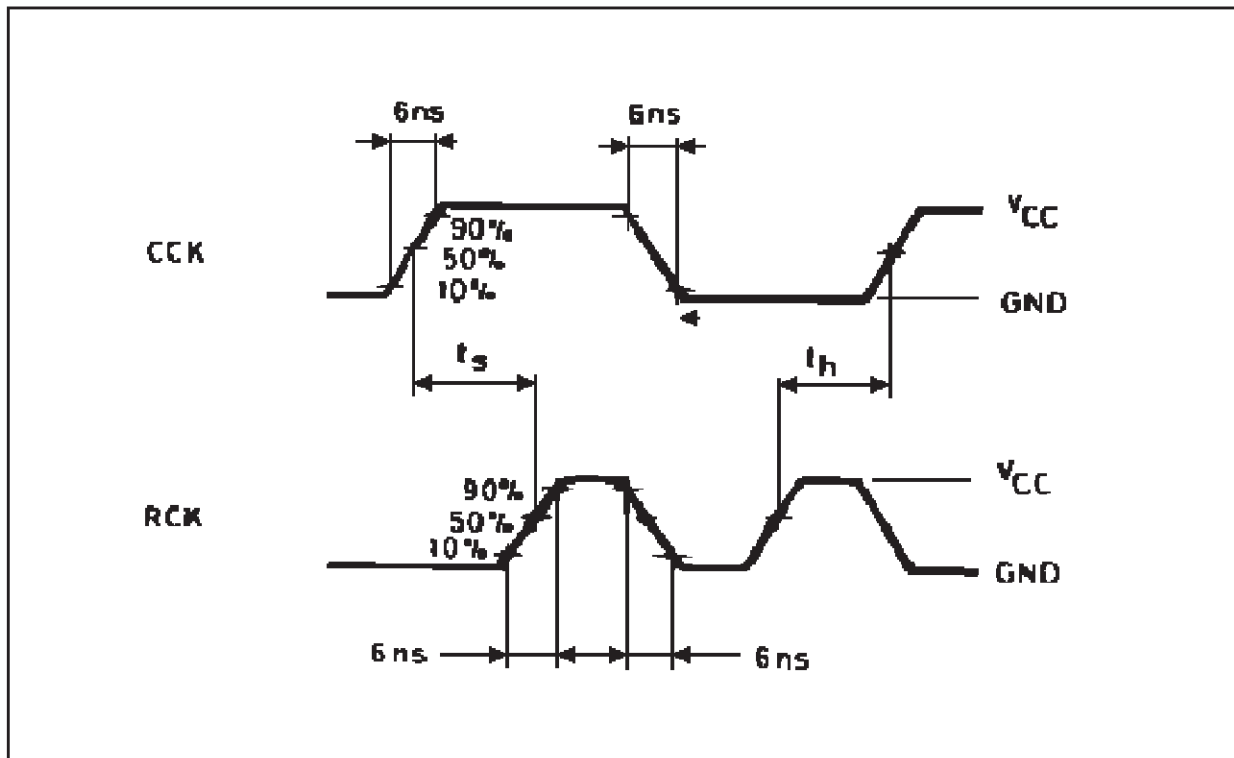

WAVEFORM 3 : PROPAGATION DELAY TIME (f=1MHz; 50% duty cycle)

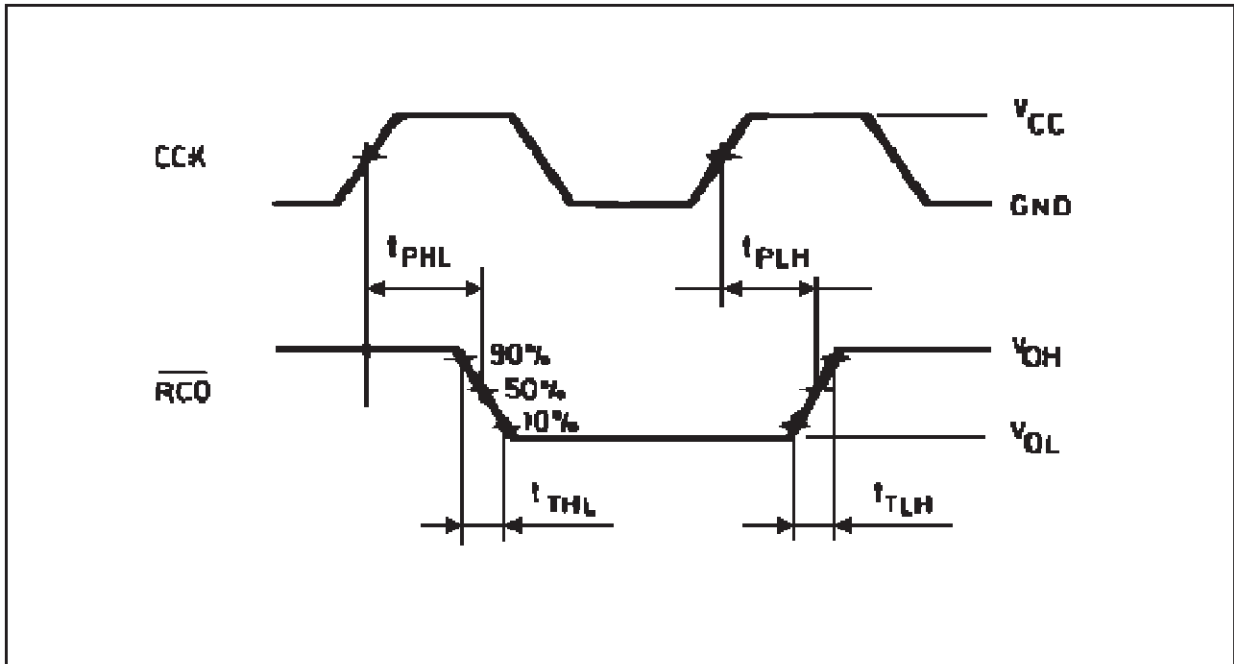

WAVEFORM 4 : MINIMUM SETUP AND HOLD TIME (f=1MHz; 50% duty cycle)

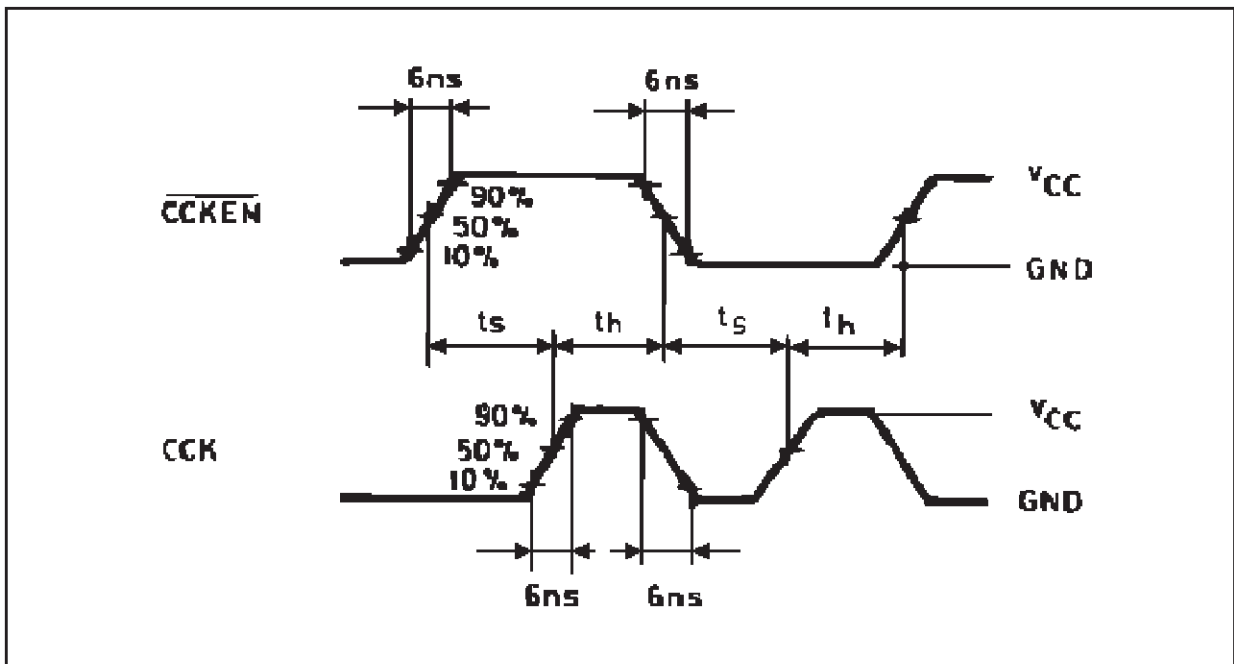

WAVEFORM 5 : MINIMUM PULSE WIDTH, REMOVAL TIME (f=1MHz; 50% duty cycle)

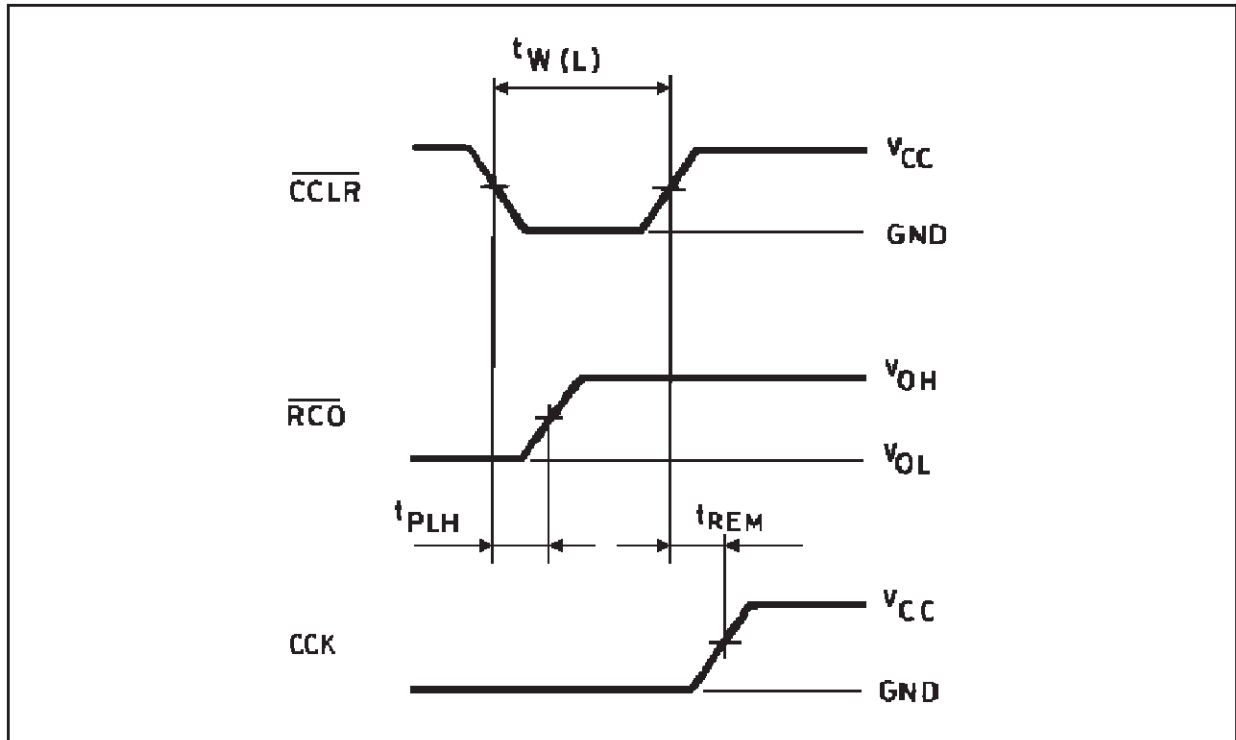

WAVEFORM 6 : OUTPUT ENABLE AND DISABLE TIME (f=1MHz; 50% duty cycle)

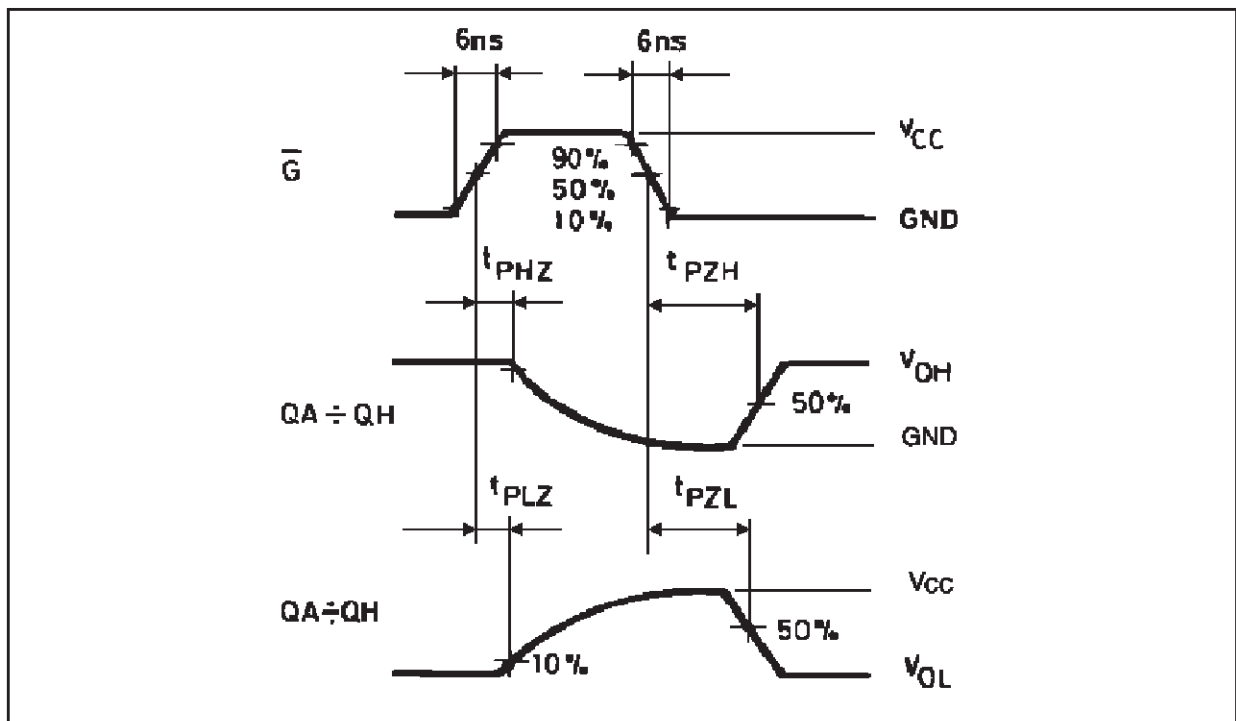

Plastic DIP-16 (0.25) MECHANICAL DATA

DIM.	mm.			inch		
	MIN.	TYP	MAX.	MIN.	TYP.	MAX.
a1	0.51			0.020		
B	0.77		1.65	0.030		0.065
b		0.5			0.020	
b1		0.25			0.010	
D			20			0.787
E		8.5			0.335	
e		2.54			0.100	
e3		17.78			0.700	
F			7.1			0.280
I			5.1			0.201
L		3.3			0.130	
Z			1.27			0.050

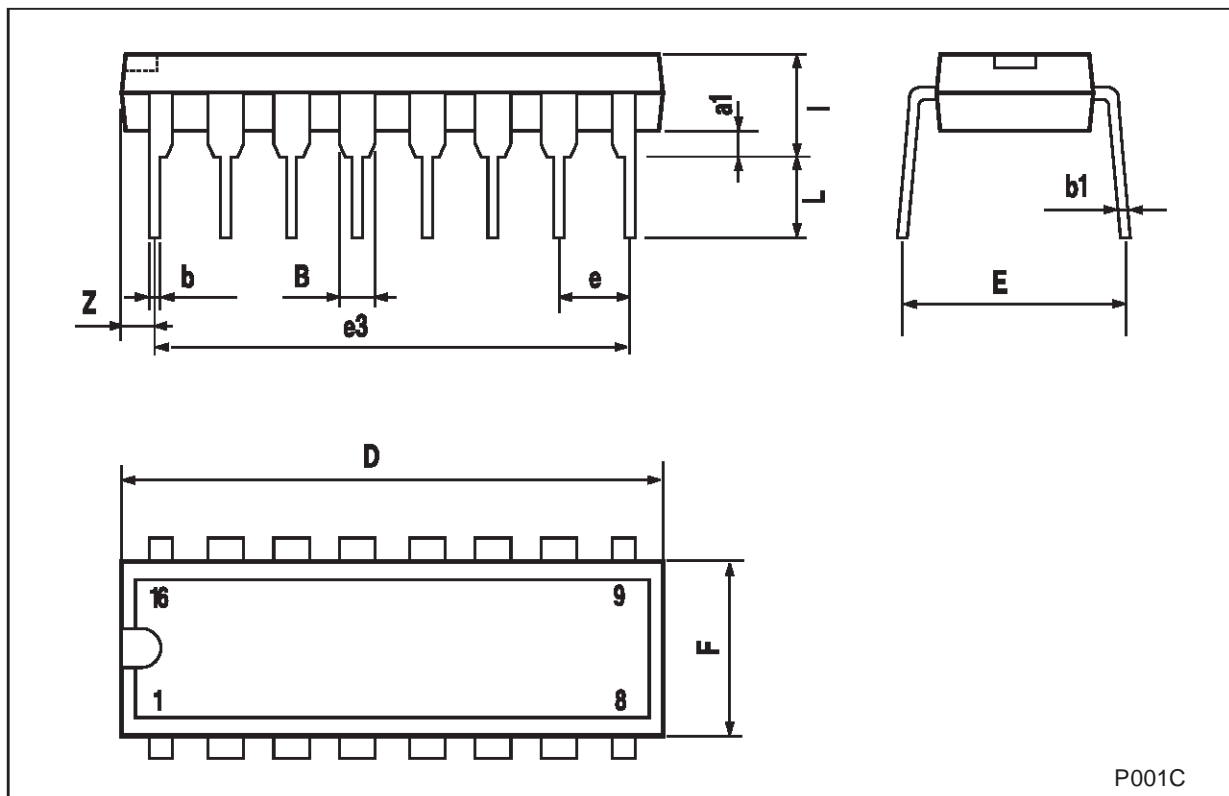

SO-16 MECHANICAL DATA

DIM.	mm.			inch		
	MIN.	TYP.	MAX.	MIN.	TYP.	MAX.
A			1.75			0.068
a1	0.1		0.2	0.003		0.007
a2			1.65			0.064
b	0.35		0.46	0.013		0.018
b1	0.19		0.25	0.007		0.010
C		0.5			0.019	
c1	45° (typ.)					
D	9.8		10	0.385		0.393
E	5.8		6.2	0.228		0.244
e		1.27			0.050	
e3		8.89			0.350	
F	3.8		4.0	0.149		0.157
G	4.6		5.3	0.181		0.208
L	0.5		1.27	0.019		0.050
M			0.62			0.024
S	8° (max.)					

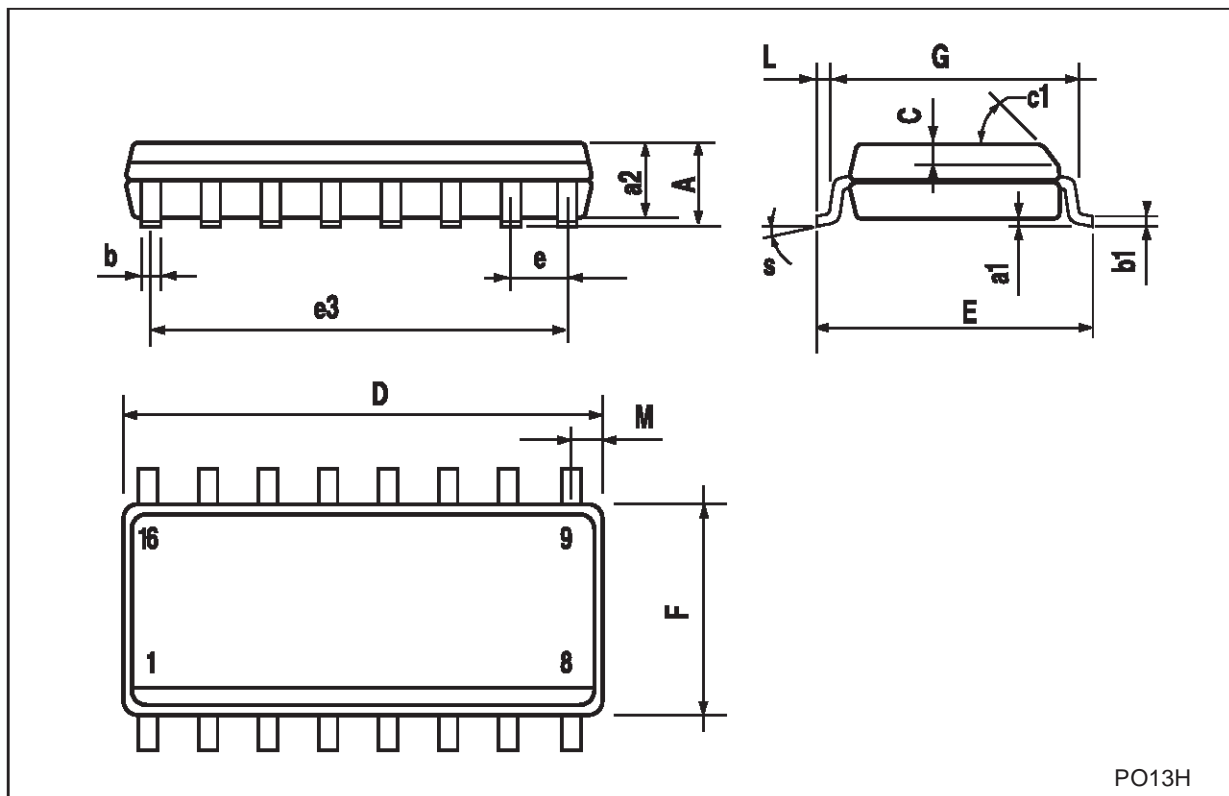

TSSOP16 MECHANICAL DATA

DIM.	mm.			inch		
	MIN.	TYP	MAX.	MIN.	TYP.	MAX.
A			1.2			0.047
A1	0.05		0.15	0.002	0.004	0.006
A2	0.8	1	1.05	0.031	0.039	0.041
b	0.19		0.30	0.007		0.012
c	0.09		0.20	0.004		0.0089
D	4.9	5	5.1	0.193	0.197	0.201
E	6.2	6.4	6.6	0.244	0.252	0.260
E1	4.3	4.4	4.48	0.169	0.173	0.176
e		0.65 BSC			0.0256 BSC	
K	0°		8°	0°		8°
L	0.45	0.60	0.75	0.018	0.024	0.030

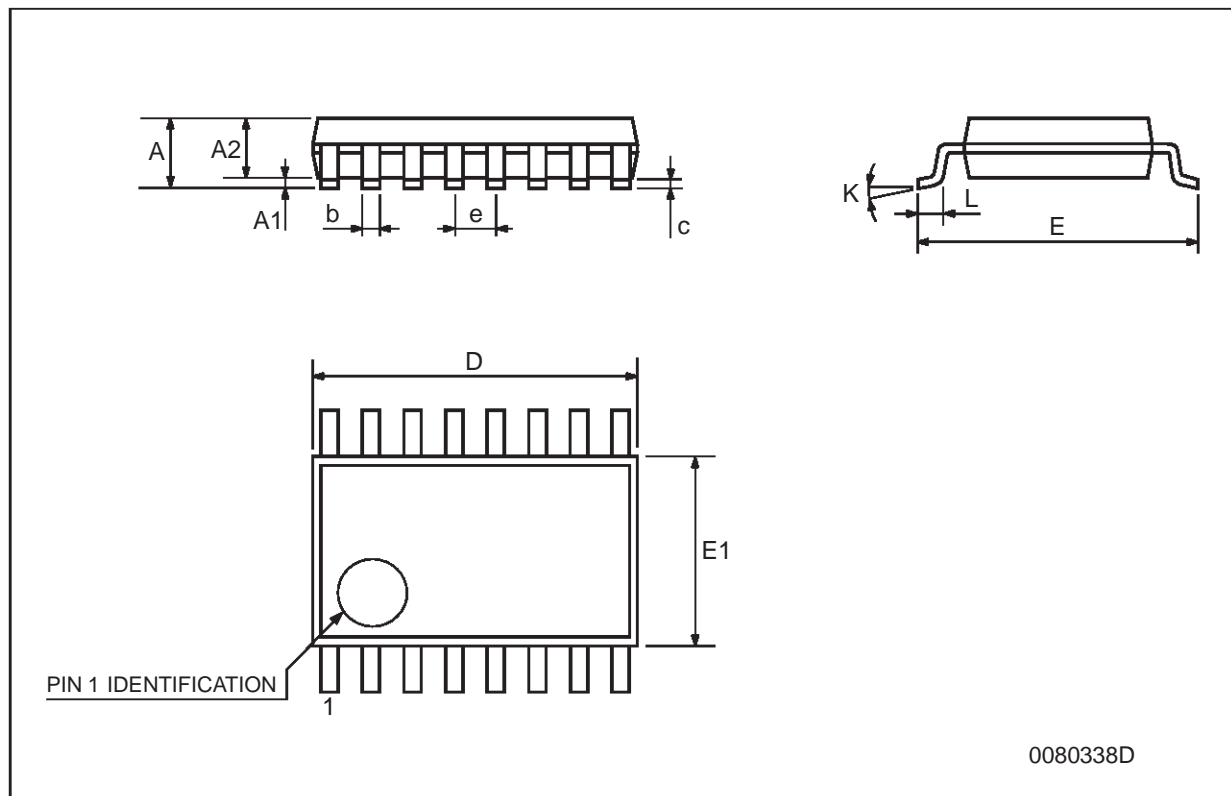

Information furnished is believed to be accurate and reliable. However, STMicroelectronics assumes no responsibility for the consequences of use of such information nor for any infringement of patents or other rights of third parties which may result from its use. No license is granted by implication or otherwise under any patent or patent rights of STMicroelectronics. Specifications mentioned in this publication are subject to change without notice. This publication supersedes and replaces all information previously supplied. STMicroelectronics products are not authorized for use as critical components in life support devices or systems without express written approval of STMicroelectronics.

© The ST logo is a registered trademark of STMicroelectronics

© 2000 STMicroelectronics - Printed in Italy - All Rights Reserved
STMicroelectronics GROUP OF COMPANIES

Australia - Brazil - China - Finland - France - Germany - Hong Kong - India - Italy - Japan - Malaysia - Malta - Morocco
Singapore - Spain - Sweden - Switzerland - United Kingdom

© <http://www.st.com>

