

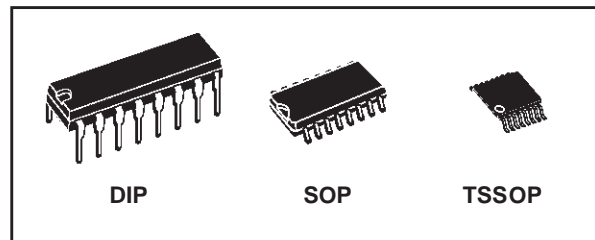

M74HCT4053

TRIPLE 2-CHANNEL ANALOG MULTIPLEXER/DEMULTIPLEXER

- **LOW POWER DISSIPATION:**
 $I_{CC} = 4\mu A$ (MAX.) at $T_A = 25^\circ C$
- **LOGIC LEVEL TRANSLATION TO ENABLE TTL LOGIC SIGNAL TO COMMUNICATE WITH $\pm 5V$ ANALOG SIGNAL**
- **LOW "ON" RESISTANCE:**
 70Ω TYP. ($V_{CC} - V_{EE} = 4.5V$)
 50Ω TYP. ($V_{CC} - V_{EE} = 9V$)
- **WIDE ANALOG INPUT VOLTAGE RANGE:**
 $\pm 6V$
- **FAST SWITCHING:**
 $t_{pd} = 13ns$ (TYP.) at $T_A = 25^\circ C$
- **LOW CROSSTALK BETWEEN SWITCHES**
- **HIGH ON/OFF OUTPUT VOLTAGE RATIO**
- **WIDE OPERATING SUPPLY VOLTAGE RANGE** ($V_{CC} - V_{EE}$) = 2V TO 12V
- **LOW SINE WAVE DISTORTION:**
0.02% at $V_{CC} - V_{EE} = 9V$
- **COMPATIBLE WITH TTL OUTPUTS:**
 $V_{IH} = 2V$ (MIN.) $V_{IL} = 0.8V$ (MAX.)
- **PIN AND FUNCTION COMPATIBLE WITH 74 SERIES 4053**



ORDER CODES

| PACKAGE | TUBE | T & R |
|---------|---------------|------------------|
| DIP | M74HCT4053B1R | |
| SOP | M74HCT4053M1R | M74HCT4053RM13TR |
| TSSOP | | M74HCT4053TTR |

DESCRIPTION

The M74HCT4053 is a triple two-channel analog MULTIPLEXER/DEMULTIPLEXER fabricated with silicon gate C²MOS technology and it is pin to pin compatible with the equivalent metal gate CMOS4000B series.

It contains 6 bidirectional and digitally controlled analog switches.

A built-in level shifting is included to allow an input range up to $\pm 6V$ (peak) for an analog signal with digital control signal of 0 to 6V.

V_{EE} supply pin is provided for analog input signals. It has an inhibit (INH) input terminal to disable all the switches when high, compatible with TTL output level. For operation as a digital multiplexer/demultiplexer, V_{EE} is connected to GND. A, B and C control inputs select one of a pair of channels, they are compatible with TTL output level.

All inputs are equipped with protection circuits against static discharge and transient excess voltage.

PIN CONNECTION AND IEC LOGIC SYMBOLS

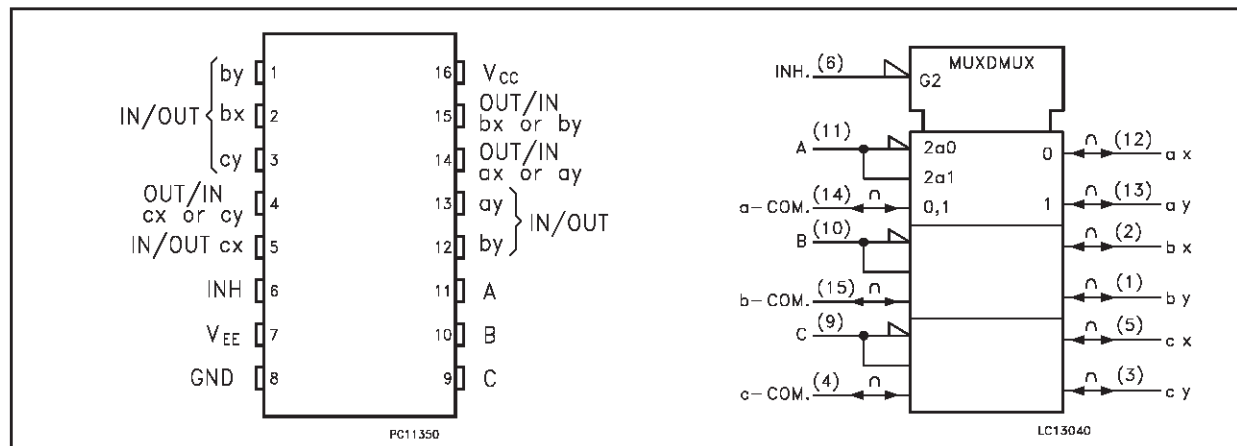

CONTROL INPUT EQUIVALENT CIRCUIT

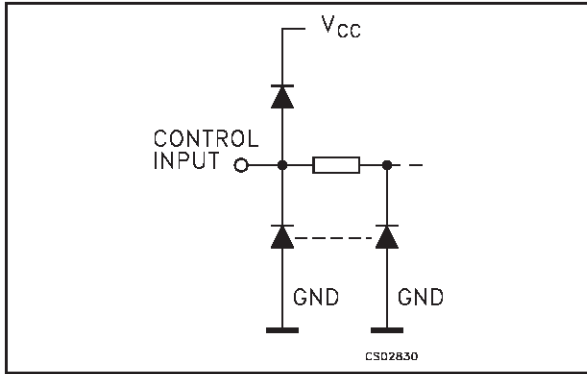

PIN DESCRIPTION

| PIN No | SYMBOL | NAME AND FUNCTION |
|-----------|----------|---------------------------|
| 2, 1 | bx, by | Independent Input Outputs |
| 5, 3 | cx, cy | Independent Input Outputs |
| 6 | INH | INHIBIT Input |
| 7 | V_{EE} | Negative Supply Voltage |
| 11, 10, 9 | A, B, C | Select Inputs |
| 12, 13 | ax, ay | Independent Input Outputs |
| 14, 15, 4 | ax to cy | Common Output/Input |
| 8 | GND | Ground (0V) |
| 16 | V_{CC} | Positive Supply Voltage |

I/O EQUIVALENT CIRCUIT

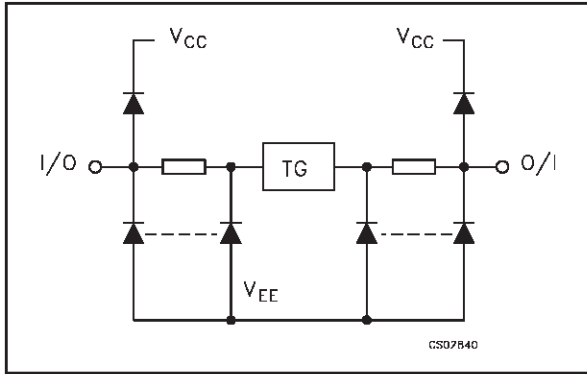

TRUTH TABLE

| INPUT STATE | | ON CHANNEL |
|-------------|-------------|----------------|
| INH | A or B or C | |
| L | L | ax or bx or cx |
| L | H | ay or by or cy |
| H | X | NONE |

FUNCTIONAL DIAGRAM

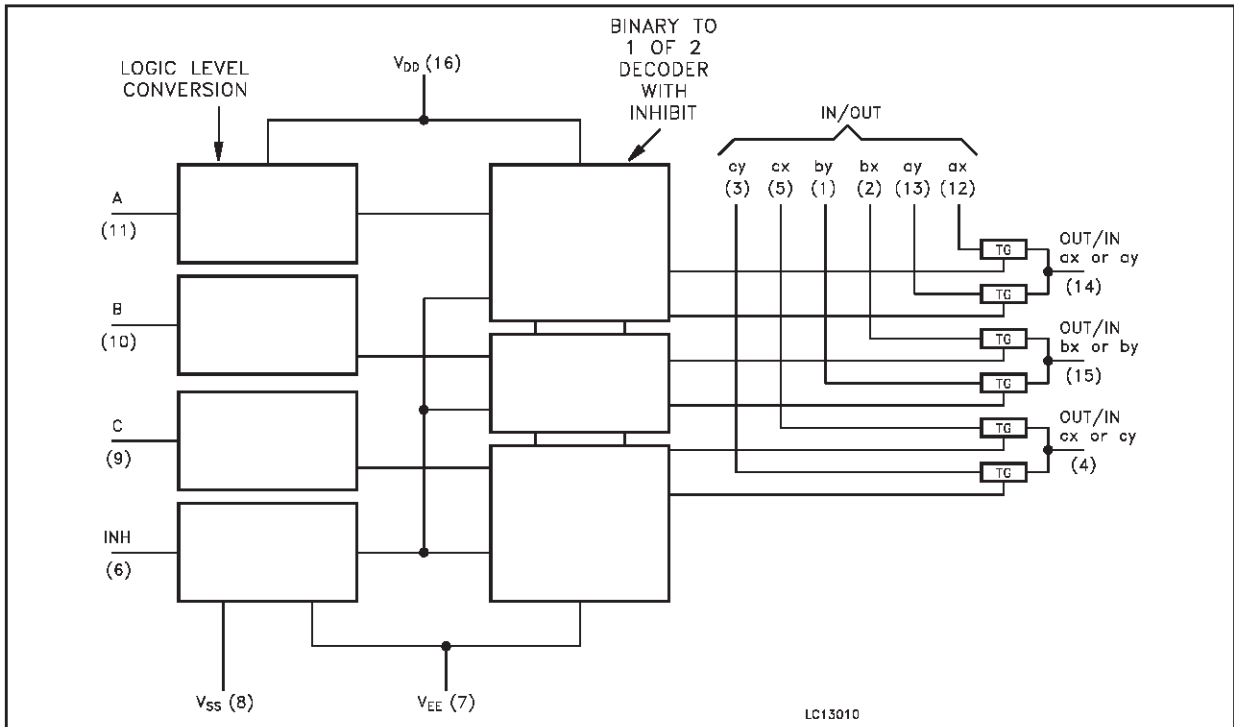

ABSOLUTE MAXIMUM RATINGS

| Symbol | Parameter | Value | Unit |
|-----------------------|-------------------------------|----------------------------------|------|
| V_{CC} | Supply Voltage | -0.5 to +7 | V |
| $V_{CC} - V_{EE}$ | Supply Voltage | -0.5 to +13 | V |
| V_I | Control Input Voltage | -0.5 to $V_{CC} + 0.5$ | V |
| $V_{I/O}$ | Switch I/O Voltage | $V_{EE} - 0.5$ to $V_{CC} + 0.5$ | V |
| I_{CK} | Control Input Diode Current | ± 20 | mA |
| $I_{I/OK}$ | I/O Diode Current | ± 20 | mA |
| I_T | Switch Through Current | ± 25 | mA |
| I_{CC} or I_{GND} | DC V_{CC} or Ground Current | ± 50 | mA |
| P_D | Power Dissipation | 500(*) | mW |
| T_{stg} | Storage Temperature | -65 to +150 | °C |
| T_L | Lead Temperature (10 sec) | 300 | °C |

Absolute Maximum Ratings are those values beyond which damage to the device may occur. Functional operation under these conditions is not implied

(*) 500mW at 65 °C; derate to 300mW by 10mW/°C from 65°C to 85°C

RECOMMENDED OPERATING CONDITIONS

| Symbol | Parameter | Value | Unit |
|-------------------|--------------------------|--------------------------|----------|
| V_{CC} | Supply Voltage | 4.5 to 5.5 | V |
| V_{EE} | Supply Voltage | -6 to 0 | V |
| $V_{CC} - V_{EE}$ | Supply Voltage | 2 to 12 | V |
| V_I | Input Voltage | 0 to V_{CC} | V |
| $V_{I/O}$ | I/O Voltage | V_{EE} to V_{CC} | V |
| T_{op} | Operating Temperature | -55 to 125 | °C |
| t_r, t_f | Input Rise and Fall Time | $V_{CC} = 4.5$ to $5.5V$ | 0 to 500 |

DC SPECIFICATIONS

| Symbol | Parameter | Test Condition | | | Value | | | | | | Unit | |
|------------------|-------------------------------------------------------|------------------------|------------------------|-----------------------------------------------------------------------------------------------------------------------------------------------|-----------------------|------|-------|-------------|-------|--------------|-------|------|
| | | V _{CC} (V) | V _{EE} (V) | | T _A = 25°C | | | -40 to 85°C | | -55 to 125°C | | |
| | | | | | Min. | Typ. | Max. | Min. | Max. | Min. | | Max. |
| V _{IHC} | High Level Input Voltage | 4.5 to 5.5 | | | 2.0 | | | 2.0 | | 2.0 | | V |
| V _{ILC} | Low Level Input Voltage | 4.5 to 5.5 | | | | | 0.8 | | 0.8 | | 0.8 | V |
| R _{ON} | ON Resistance | 4.5 | GND | V _I = V _{IHC} or V _{ILC} V _{I/O} = V _{CC} to V _{EE} I _{I/O} ≤ 2mA | | 85 | 180 | | 225 | | 270 | Ω |
| | | 4.5 | -4.5 | | | 55 | 120 | | 150 | | 180 | |
| | | 4.5 | GND | V _I = V _{IHC} or V _{ILC} V _{I/O} = V _{CC} or V _{EE} I _{I/O} ≤ 2mA | | 70 | 150 | | 190 | | 230 | |
| | | 4.5 | -4.5 | | | 50 | 100 | | 125 | | 150 | |
| ΔR _{ON} | Difference of ON Resistance between switches | 4.5 | GND | V _I = V _{IHC} or V _{ILC} V _{I/O} = V _{CC} or V _{EE} I _{I/O} ≤ 2mA | | 10 | 30 | | 35 | | 45 | Ω |
| | | 4.5 | -4.5 | | | 5 | 12 | | 15 | | 18 | |
| I _{OFF} | Input/Output Leakage Current (SWITCH OFF) | 5.5 | GND | V _{OS} = V _{CC} or GND V _{IS} = GND or V _{CC} V _I = V _{ILC} or V _{IHC} | | | ±0.06 | | ± 0.6 | | ± 1.0 | μA |
| | | 5.5 | -6.0 | | | | ± 0.1 | | ± 1 | | ± 1 | |
| I _{IZ} | Switch Input Leakage Current (SWITCH ON, OUTPUT OPEN) | 5.5 | GND | V _{OS} = V _{CC} or GND V _I = V _{IHC} or V _{ILC} | | | ±0.06 | | ± 0.6 | | ± 1.0 | μA |
| | | 5.5 | -6.0 | | | | ± 0.1 | | ± 1 | | ± 1 | |
| I _I | Input Leakage Current | 5.5 | GND | V _I = V _{CC} or GND | | | ± 0.1 | | ± 0.1 | | ± 1 | μA |
| | | | | | | | | | | | | |
| I _{CC} | Quiescent Supply Current | 5.5 | GND | V _I = V _{CC} or GND | | | 4 | | 40 | | 80 | μA |
| | | 5.5 | -6.0 | | | | 8 | | 80 | | 160 | |
| ΔI _{CC} | Additional Quiescent Supply Current per input pin | 4.5 to 5.5 | GND | V _I = V _{CC} - 2.1V other input at V _{CC} or GND | | 100 | 360 | | 450 | | 490 | μA |

AC ELECTRICAL CHARACTERISTICS ($C_L = 50 \text{ pF}$, Input $t_r = t_f = 6 \text{ ns}$)

| Symbol | Parameter | Test Condition | | | Value | | | | | | Unit | |
|------------------------|-------------------------------------------|-----------------|-----------------|---------------------------|--------------------------|------|------|------------------------------------|------|-------------------------------------|------|------|
| | | V_{CC} (V) | V_{EE} (V) | | $T_A = 25^\circ\text{C}$ | | | $-40 \text{ to } 85^\circ\text{C}$ | | $-55 \text{ to } 125^\circ\text{C}$ | | |
| | | | | | Min. | Typ. | Max. | Min. | Max. | Min. | | Max. |
| $\Phi_{I/O}$ | Phase Difference Between Input and Output | 4.5 | GND | $C_L = 50 \text{ pF}$ | | 5 | 12 | | 15 | | 18 | ns |
| | | 4.5 | -4.5 | | | 4 | 8 | | 10 | | 12 | |
| t_{PZL} t_{PZH} | Output Enable Time | 4.5 | GND | $R_L = 1 \text{ K}\Omega$ | | 13 | 45 | | 56 | | 68 | ns |
| | | 4.5 | -4.5 | $C_L = 50 \text{ pF}$ | | 11 | 34 | | 43 | | 51 | |
| t_{PLZ} t_{PHZ} | Output Disable Time | 4.5 | GND | $R_L = 1 \text{ K}\Omega$ | | 25 | 38 | | 48 | | 58 | ns |
| | | 4.5 | -4.5 | $C_L = 50 \text{ pF}$ | | 19 | 31 | | 39 | | 47 | |

CAPACITANCE CHARACTERISTICS

| Symbol | Parameter | Test Condition | | | Value | | | | | | Unit | |
|-----------|----------------------------------------|-----------------|-----------------|--|--------------------------|------|------|------------------------------------|------|-------------------------------------|------|------|
| | | V_{CC} (V) | V_{EE} (V) | | $T_A = 25^\circ\text{C}$ | | | $-40 \text{ to } 85^\circ\text{C}$ | | $-55 \text{ to } 125^\circ\text{C}$ | | |
| | | | | | Min. | Typ. | Max. | Min. | Max. | Min. | | Max. |
| C_{IN} | Input Capacitance | 5.0 | | | | 5 | 10 | | 10 | | 10 | pF |
| $C_{I/O}$ | Common Terminal Capacitance | 5.0 | -5.0 | | | 11 | 20 | | 20 | | 20 | pF |
| $C_{I/O}$ | Switch Terminal Capacitance | 5.0 | -5.0 | | | 7 | 15 | | 15 | | 15 | pF |
| C_{IOS} | Feed Through Capacitance | 5.0 | -5.0 | | | 0.75 | 2 | | 2 | | 2 | pF |
| C_{PD} | Power Dissipation Capacitance (note 1) | 5.0 | GND | | | 67 | | | | | | pF |

1) C_{PD} is defined as the value of the IC's internal equivalent capacitance which is calculated from the operating current consumption without load. (Refer to Test Circuit). Average operating current can be obtained by the following equation. $I_{CC(opr)} = C_{PD} \times V_{CC} \times f_{IN} + I_{CC}$

ANALOG SWITCH CHARACTERISTICS (GND = 0V; T_A = 25°C)

| Symbol | Parameter | Test Condition | | | Value | Unit | |
|------------------|--------------------------------------------|------------------------|------------------------|-----------------------------------------------------------------------------------------------------------------------------------------------------------------------------------------------------------------------|-------------------------------------------------------------------------|-------|---|
| | | V _{CC} (V) | V _{EE} (V) | V _{IN} (V _{p-p}) | | | |
| | Sine Wave Distortion | 2.25 | -2.25 | 4 | f _{IN} = 1 KHz R _L = 10 KΩ, C _L = 50 pF | 0.025 | % |
| | | 4.5 | -4.5 | 8 | | 0.020 | |
| | Sine Wave Distortion | 2.25 | -2.25 | 4 | f _{IN} = 10 KHz R _L = 10 KΩ, C _L = 50 pF | 0.12 | % |
| | | 4.5 | -4.5 | 8 | | 0.06 | |
| f _{MAX} | Frequency Response (Switch ON) (*) | 2.25 | -2.25 | Adjust f _{IN} voltage to obtain 0 dBm at V _{OS} . Increase f _{IN} Frequency until dB meter reads -3dB R _L = 50Ω, C _L = 10 pF, f _{IN} = 1KHz sine wave | 120 | MHz | |
| | | 4.5 | -4.5 | | 190 | | |
| f _{MAX} | Frequency Response (Switch ON) (**) | 2.25 | -2.25 | Adjust f _{IN} voltage to obtain 0 dBm at V _{OS} . Increase f _{IN} Frequency until dB meter reads -3dB R _L = 50Ω, C _L = 10 pF, f _{IN} = 1KHz sine wave | 95 | MHz | |
| | | 4.5 | -4.5 | | 150 | | |
| | | 6.0 | -6.0 | | | | |
| | Feed through Attenuation (Switch OFF) | 2.25 | -2.25 | V _{IN} is centered at (V _{CC} - V _{EE})/2 Adjust input for 0 dBm R _L = 600Ω, C _L = 50 pF, f _{IN} = 1MHz sine wave | -50 | dB | |
| | | 4.5 | -4.5 | | -50 | | |
| | Crosstalk (Control Input to Signal Output) | 4.5 | 0 | Adjust R _L at set up so that I _S = 0A. R _L = 600Ω, C _L = 50 pF, f _{IN} = 1MHz square wave between V _{CC} and GND tr=tf= 6 ns | 60 | mV | |
| | | 4.5 | -4.5 | | 140 | | |
| | Crosstalk (between any two switches) | 2.25 | -2.25 | Adjust V _{IN} to obtain 0dBm at input R _L = 600Ω, C _L = 50 pF, f _{IN} = 1MHz sine wave | -50 | dB | |
| | | 4.5 | -4.5 | | -50 | | |

(*) Input COMMON Terminal, and measured at SWITCH Terminal

(**) Input SWITCH Terminal, and measured at common Terminal

NOTE: These characteristics are determined by the design of the device.

SWITCHING CHARACTERISTICS TEST CIRCUIT

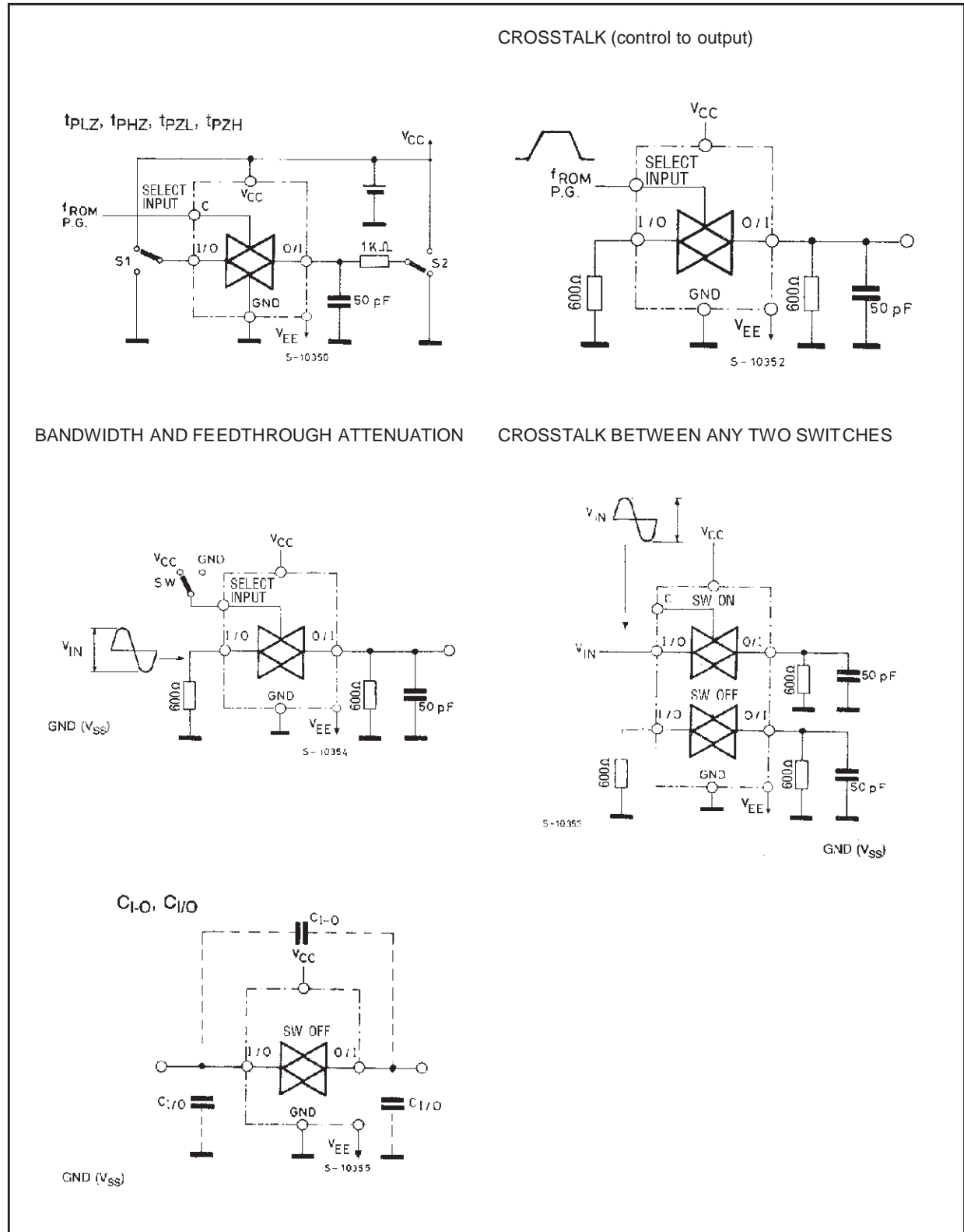

SWITCHING CHARACTERISTICS WAVEFORM

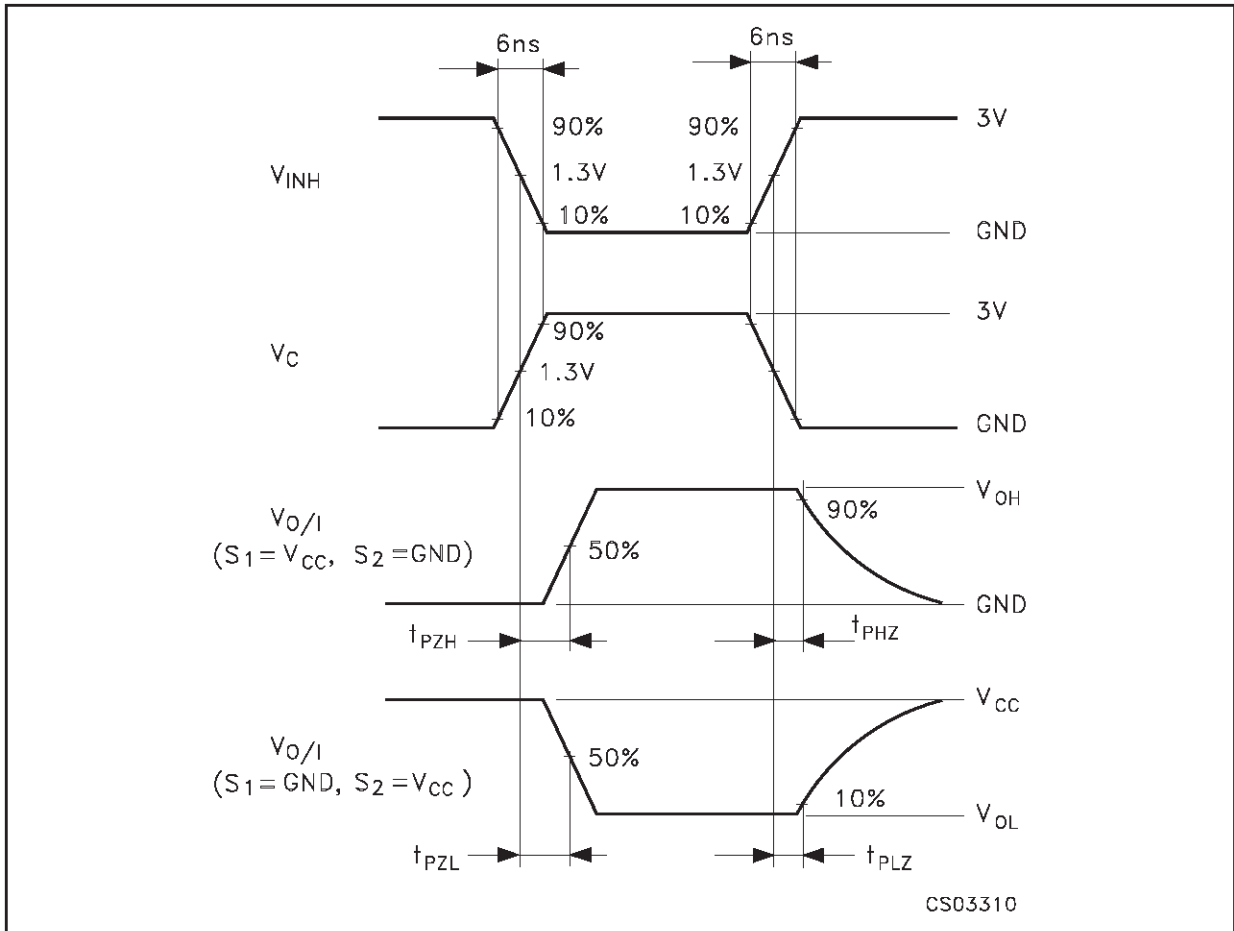

CHANNEL RESISTANCE (R_{ON})

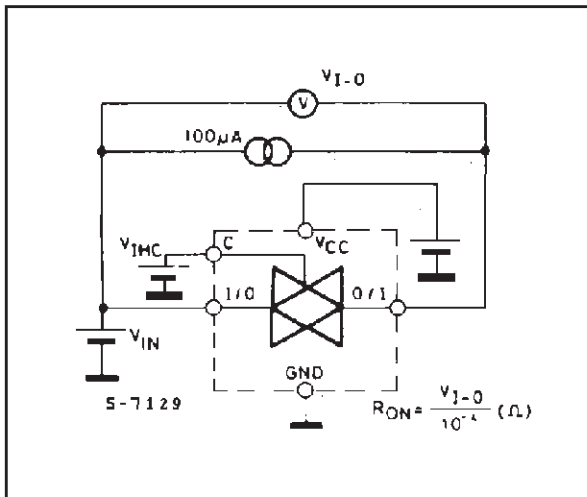

I_{CC} (Opr.)

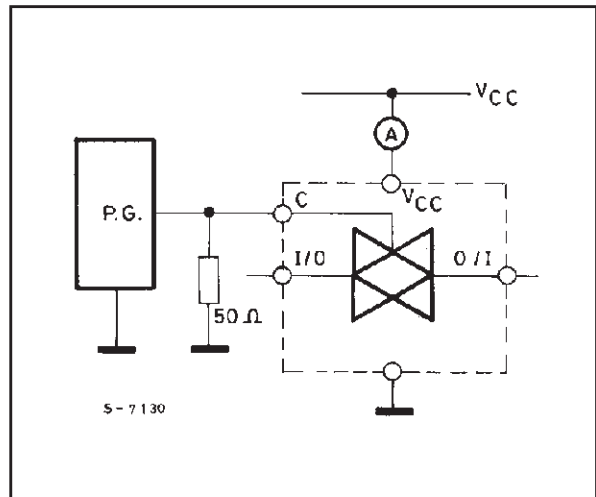

Plastic DIP-16 (0.25) MECHANICAL DATA

| DIM. | mm. | | | inch | | |
|------|------|-------|------|-------|-------|-------|
| | MIN. | TYP | MAX. | MIN. | TYP. | MAX. |
| a1 | 0.51 | | | 0.020 | | |
| B | 0.77 | | 1.65 | 0.030 | | 0.065 |
| b | | 0.5 | | | 0.020 | |
| b1 | | 0.25 | | | 0.010 | |
| D | | | 20 | | | 0.787 |
| E | | 8.5 | | | 0.335 | |
| e | | 2.54 | | | 0.100 | |
| e3 | | 17.78 | | | 0.700 | |
| F | | | 7.1 | | | 0.280 |
| I | | | 5.1 | | | 0.201 |
| L | | 3.3 | | | 0.130 | |
| Z | | | 1.27 | | | 0.050 |

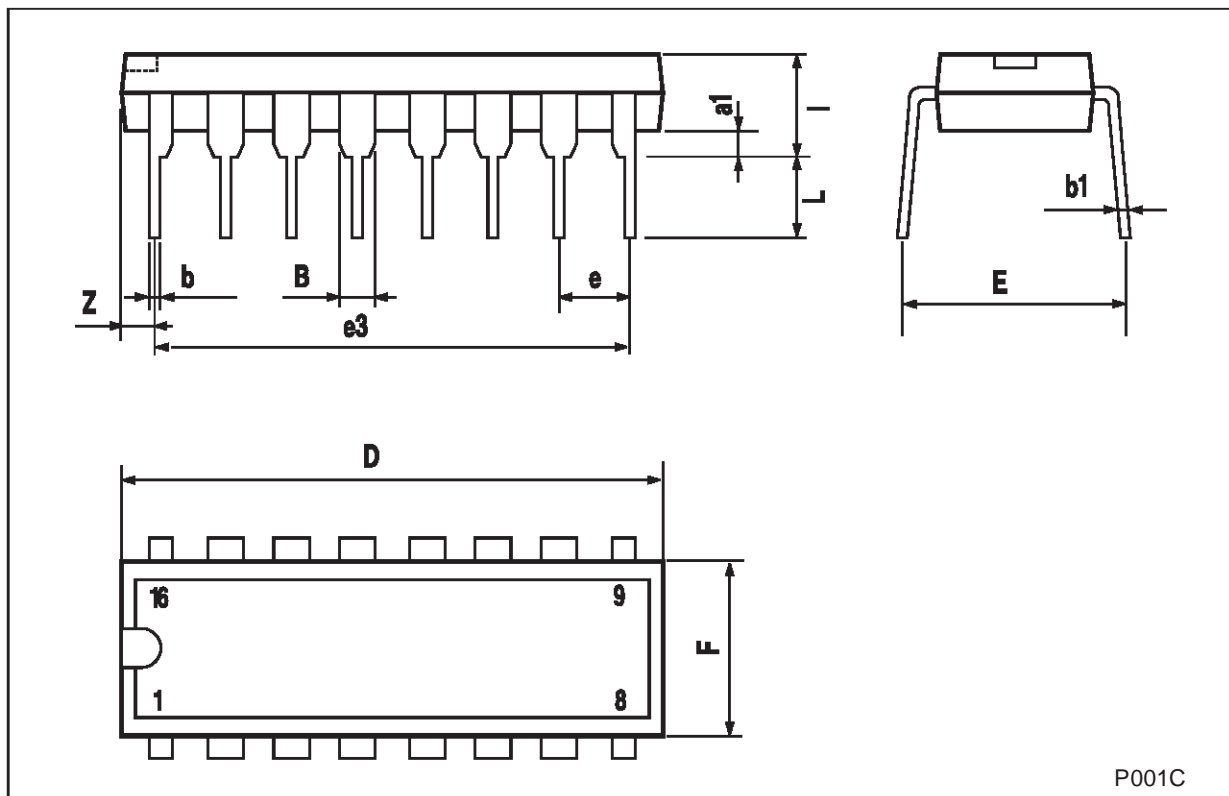

SO-16 MECHANICAL DATA

| DIM. | mm. | | | inch | | |
|------|------------|------|------|-------|-------|-------|
| | MIN. | TYP. | MAX. | MIN. | TYP. | MAX. |
| A | | | 1.75 | | | 0.068 |
| a1 | 0.1 | | 0.2 | 0.003 | | 0.007 |
| a2 | | | 1.65 | | | 0.064 |
| b | 0.35 | | 0.46 | 0.013 | | 0.018 |
| b1 | 0.19 | | 0.25 | 0.007 | | 0.010 |
| C | | 0.5 | | | 0.019 | |
| c1 | 45° (typ.) | | | | | |
| D | 9.8 | | 10 | 0.385 | | 0.393 |
| E | 5.8 | | 6.2 | 0.228 | | 0.244 |
| e | | 1.27 | | | 0.050 | |
| e3 | | 8.89 | | | 0.350 | |
| F | 3.8 | | 4.0 | 0.149 | | 0.157 |
| G | 4.6 | | 5.3 | 0.181 | | 0.208 |
| L | 0.5 | | 1.27 | 0.019 | | 0.050 |
| M | | | 0.62 | | | 0.024 |
| S | 8° (max.) | | | | | |

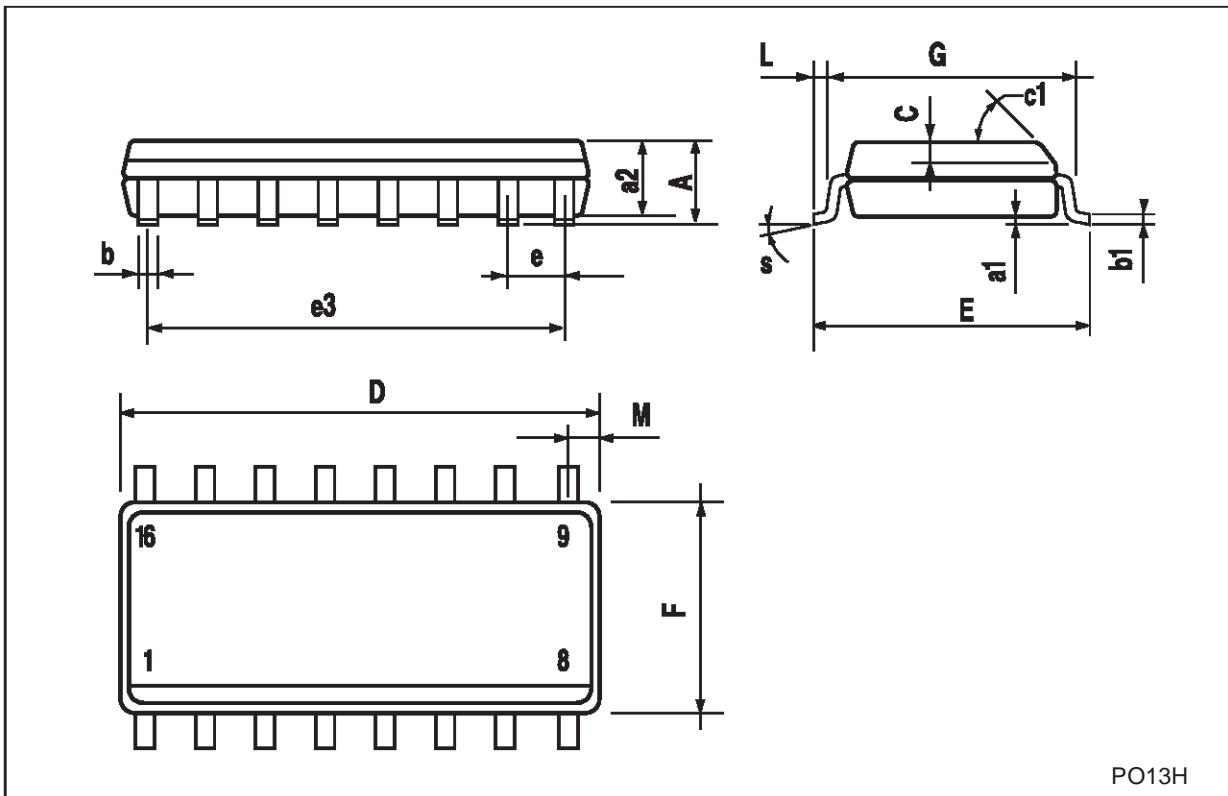

PO13H

TSSOP16 MECHANICAL DATA

| DIM. | mm. | | | inch | | |
|------|------|----------|------|-------|------------|--------|
| | MIN. | TYP | MAX. | MIN. | TYP. | MAX. |
| A | | | 1.2 | | | 0.047 |
| A1 | 0.05 | | 0.15 | 0.002 | 0.004 | 0.006 |
| A2 | 0.8 | 1 | 1.05 | 0.031 | 0.039 | 0.041 |
| b | 0.19 | | 0.30 | 0.007 | | 0.012 |
| c | 0.09 | | 0.20 | 0.004 | | 0.0089 |
| D | 4.9 | 5 | 5.1 | 0.193 | 0.197 | 0.201 |
| E | 6.2 | 6.4 | 6.6 | 0.244 | 0.252 | 0.260 |
| E1 | 4.3 | 4.4 | 4.48 | 0.169 | 0.173 | 0.176 |
| e | | 0.65 BSC | | | 0.0256 BSC | |
| K | 0° | | 8° | 0° | | 8° |
| L | 0.45 | 0.60 | 0.75 | 0.018 | 0.024 | 0.030 |

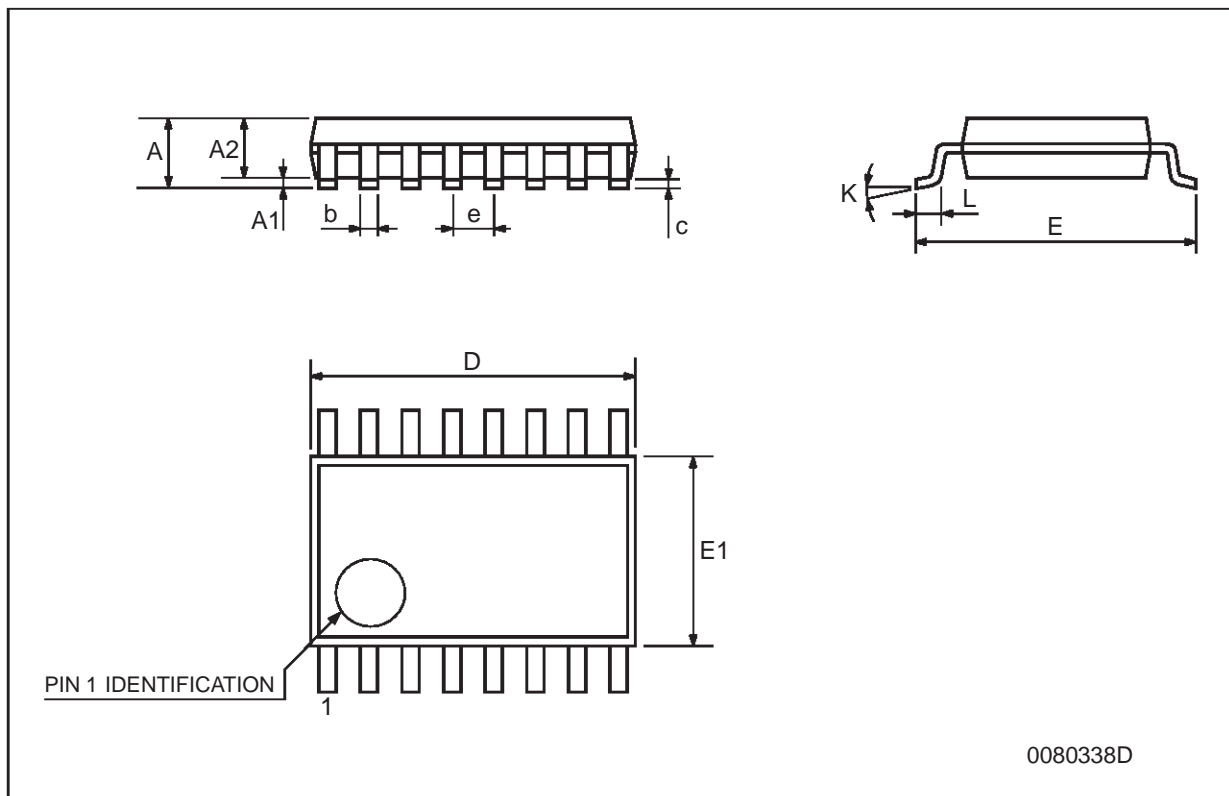

Information furnished is believed to be accurate and reliable. However, STMicroelectronics assumes no responsibility for the consequences of use of such information nor for any infringement of patents or other rights of third parties which may result from its use. No license is granted by implication or otherwise under any patent or patent rights of STMicroelectronics. Specifications mentioned in this publication are subject to change without notice. This publication supersedes and replaces all information previously supplied. STMicroelectronics products are not authorized for use as critical components in life support devices or systems without express written approval of STMicroelectronics.

© The ST logo is a registered trademark of STMicroelectronics

© 2001 STMicroelectronics - Printed in Italy - All Rights Reserved
STMicroelectronics GROUP OF COMPANIES

Australia - Brazil - China - Finland - France - Germany - Hong Kong - India - Italy - Japan - Malaysia - Malta - Morocco
Singapore - Spain - Sweden - Switzerland - United Kingdom

© <http://www.st.com>