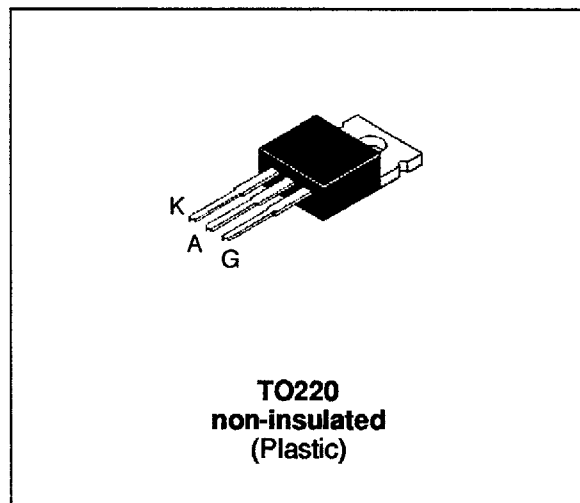

SENSITIVE GATE SCR
FEATURES

- $I_{T(RMS)} = 8A$
- $V_{DRM} = 200V$ to $800V$
- Low $I_{GT} < 200 \mu A$

DESCRIPTION

The S0802xH series of SCRs uses a high performance MESA GLASS PNP technology. These parts are intended for general purpose applications where low gate sensitivity is required.

ABSOLUTE RATINGS (limiting values)

Symbol	Parameter		Value	Unit
$I_{T(RMS)}$	RMS on-state current (180° conduction angle)	$T_c = 95^\circ C$	8	A
$I_{T(AV)}$	Mean on-state current (180° conduction angle)	$T_c = 95^\circ C$	5	A
I_{TSM}	Non repetitive surge peak on-state current (T_j initial = $25^\circ C$)	$t_p = 8.3$ ms	73	A
		$t_p = 10$ ms	70	
$I^2 t$	$I^2 t$ Value for fusing	$t_p = 10$ ms	24	$A^2 s$
di/dt	Critical rate of rise of on-state current $I_G = 10$ mA $di_G/dt = 0.1$ A/ μs .		100	A/ μs
T_{stg} T_j	Storage and operating junction temperature range		- 40, +150 - 40, +125	$^\circ C$
T_l	Maximum lead temperature for soldering during 10s at 4.5mm from case		260	$^\circ C$

Symbol	Parameter	Voltage				Unit
		B	D	M	N	
V_{DRM} V_{RRM}	Repetitive peak off-state voltage $T_j = 125^\circ C$ $R_{GK} = 1K\Omega$	200	400	600	800	V

S0802xH

THERMAL RESISTANCES

Symbol	Parameter	Value	Unit
Rth(j-a)	Junction to ambient	60	°C/W
Rth(j-c)	Junction to case for DC	4	°C/W

GATE CHARACTERISTICS (maximum values)

$P_{G(AV)} = 0.5 \text{ W}$ $P_{GM} = 5 \text{ W}$ ($t_p = 20 \mu\text{s}$) $I_{GM} = 2 \text{ A}$ ($t_p = 20 \mu\text{s}$)

ELECTRICAL CHARACTERISTICS

Symbol	Test Conditions				Sensitivity	Unit		
					02			
I_{GT}	$V_D = 12\text{V (DC)}$	$R_L = 140\Omega$	$T_j = 25^\circ\text{C}$	MAX	200	μA		
V_{GT}	$V_D = 12\text{V (DC)}$	$R_L = 140\Omega$	$T_j = 25^\circ\text{C}$	MAX	1.5	V		
V_{GD}	$V_D = V_{DRM}$	$R_L = 3.3\text{k}\Omega$ $R_{GK} = 1 \text{ K}\Omega$	$T_j = 125^\circ\text{C}$	MIM	0.1	V		
V_{RGM}	$I_{RG} = 10\mu\text{A}$		$T_j = 25^\circ\text{C}$	MIN	8	V		
tg _d	$V_D = V_{DRM}$	$I_{TM} = 3 \times I_{T(AV)}$ $di_G/dt = 0.1\text{A}/\mu\text{s}$	$I_G = 10\text{mA}$	$T_j = 25^\circ\text{C}$	TYP	0.5	μs	
I_H	$I_T = 50\text{mA}$	$R_{GK} = 1 \text{ K}\Omega$	$T_j = 25^\circ\text{C}$	MAX	10	mA		
I_L	$I_G = 1\text{mA}$	$R_{GK} = 1 \text{ K}\Omega$	$T_j = 25^\circ\text{C}$	MAX	20	mA		
V_{TM}	$I_{TM} = 16\text{A}$	$t_p = 380\mu\text{s}$	$T_j = 25^\circ\text{C}$	MAX	1.6	V		
I_{DRM} I_{RRM}	$V_D = V_{DRM}$	$R_{GK} = 1 \text{ K}\Omega$	$T_j = 25^\circ\text{C}$	MAX	5	μA		
	$V_R = V_{RRM}$		$T_j = 110^\circ\text{C}$	MAX	500	μA		
dV/dt	$V_D = 67\%V_{DRM}$	$R_{GK} = 1 \text{ K}\Omega$	$T_j = 110^\circ\text{C}$	TYP	10	V/ μs		
tq	$I_{TM} = 3 \times I_{T(AV)}$	$V_R = 35\text{V}$ $di/dt = 10\text{A}/\mu\text{s}$ $t_p = 100\mu\text{s}$ $dV/dt = 2\text{V}/\mu\text{s}$	$V_D = 67\%V_{DRM}$	$R_{GK} = 1 \text{ K}\Omega$	$T_j = 110^\circ\text{C}$	MAX	100	μs

ORDERING INFORMATION

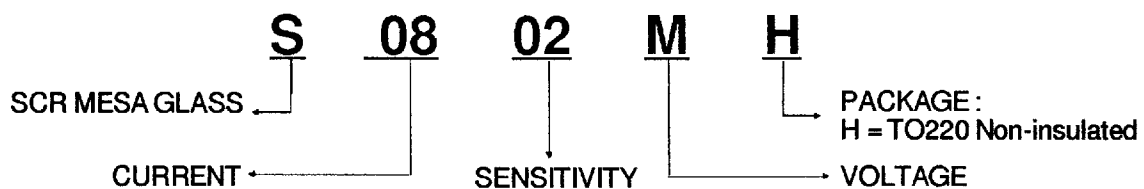

Fig.1 : Maximum average power dissipation versus average on-state current.

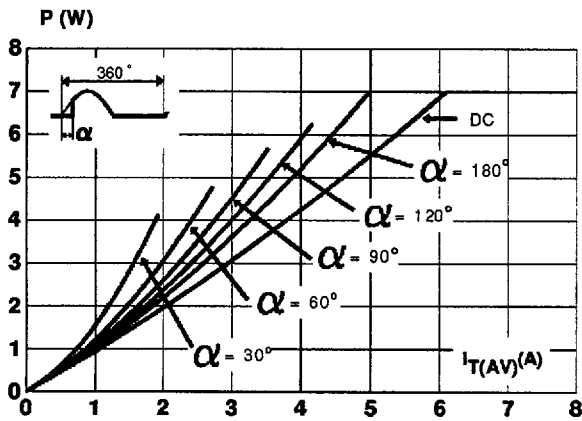

Fig.2 : Correlation between maximum average power dissipation and maximum allowable temperature (Tamb and Tcase) for different thermal resistances heatsink + contact.

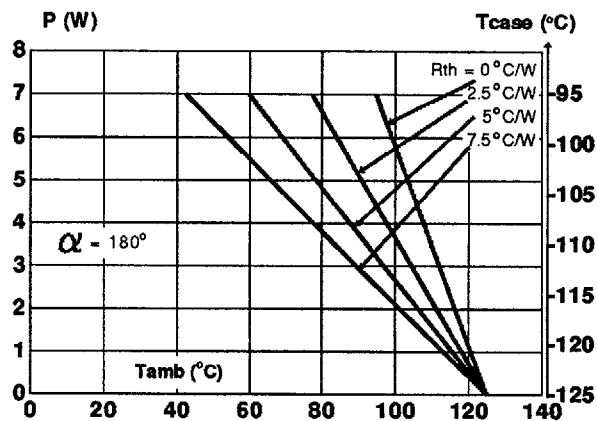

Fig.3 : Average on-state current versus case temperature.

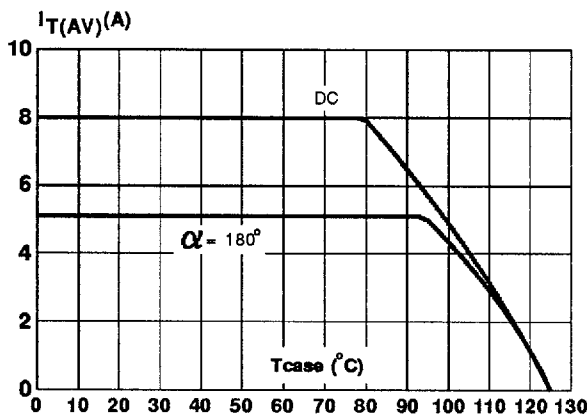

Fig.4 : Relative variation of thermal impedance versus pulse duration.

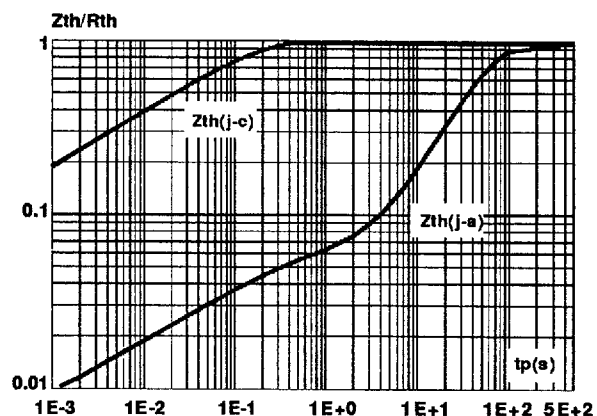

Fig.5 : Relative variation of gate trigger current and holding current versus junction temperature.

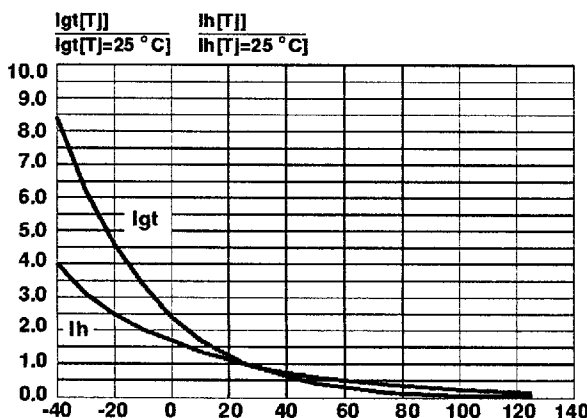

Fig.6 : Non repetitive surge peak on-state current versus number of cycles.

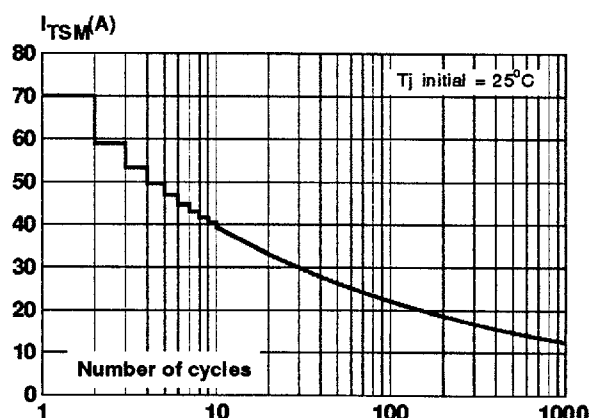

Fig.7 : Non repetitive surge peak on-state current for a sinusoidal pulse with width : $t_p \leq 10\text{ms}$, and corresponding value of I^2t .

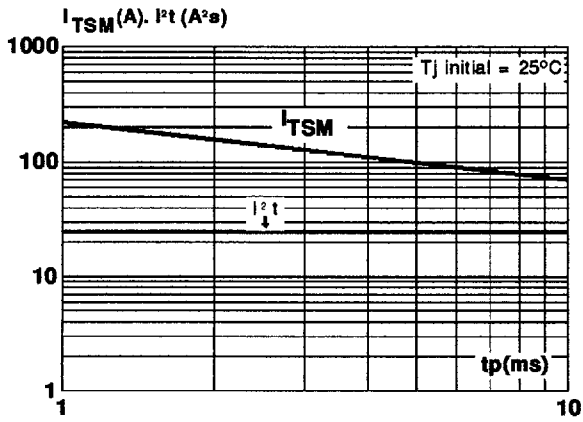
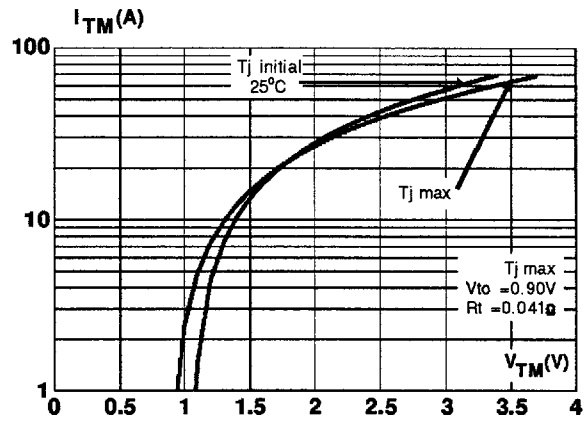
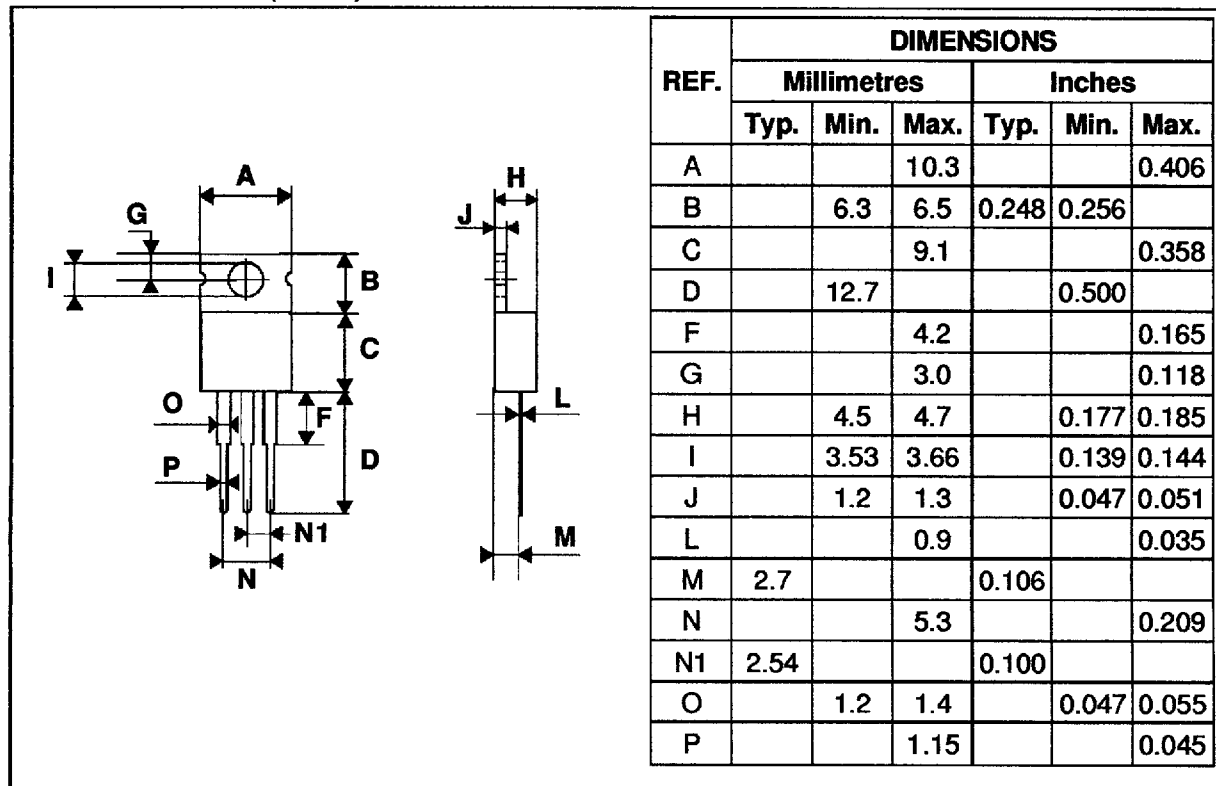

Fig.8 : On-state characteristics (maximum values).



PACKAGE MECHANICAL DATA
TO220 Non-insulated (Plastic)



Marking : Type number
Weight : 1.8 g

Information furnished is believed to be accurate and reliable. However, SGS-THOMSON Microelectronics assumes no responsibility for the consequences of use of such information nor for any infringement of patents or other rights of third parties which may result from its use. No license is granted by implication or otherwise under any patent or patent rights of SGS-THOMSON Microelectronics. Specifications mentioned in this publication are subject to change without notice. This publication supersedes and replaces all information previously supplied. SGS-THOMSON Microelectronics products are not authorized for use as critical components in life support devices or systems without express written approval of SGS-THOMSON Microelectronics.

© 1995 SGS-THOMSON Microelectronics - All rights reserved.

SGS-THOMSON Microelectronics GROUP OF COMPANIES

Australia - Brazil - France - Germany - Hong Kong - Italy - Japan - Korea - Malaysia - Malta - Morocco - The Netherlands
Singapore - Spain - Sweden - Switzerland - Taiwan - Thailand - United Kingdom - U.S.A.