



SD2932

RF POWER TRANSISTORS HF/VHF/UHF N-CHANNEL MOSFETs

- GOLD METALLIZATION
- EXCELLENT THERMAL STABILITY
- COMMON SOURCE CONFIGURATION, PUSH PULL
- $P_{OUT} = 300 \text{ W MIN. WITH } 15 \text{ dB GAIN @ } 175 \text{ MHz}$

DESCRIPTION

The SD2932 is a gold metallized N-Channel MOS field-effect RF power transistor. The SD2932 is intended for use in 50 V dc large signal applications up to 250 MHz.

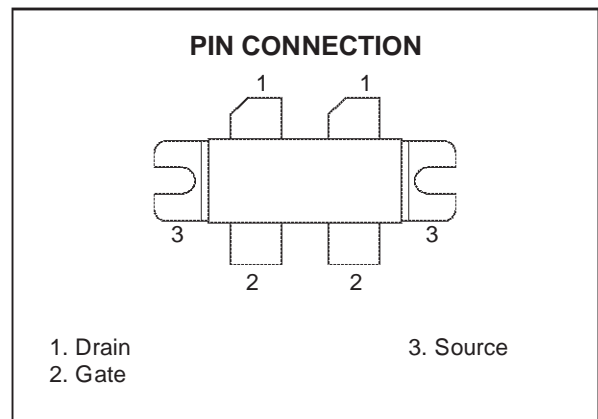
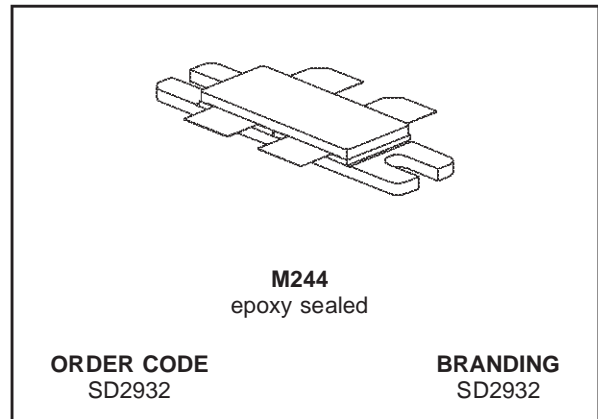

ABSOLUTE MAXIMUM RATINGS ($T_{CASE} = 25^\circ\text{C}$)

Symbol	Parameter	Value	Unit
$V_{(BR)DSS}$	Drain Source Voltage	125	V
V_{DGR}	Drain-Gate Voltage ($R_{GS} = 1M\Omega$)	125	V
V_{GS}	Gate-Source Voltage	± 20	V
I_D	Drain Current	40	A
P_{DISS}	Power Dissipation	500	W
T_j	Max. Operating Junction Temperature	+200	$^\circ\text{C}$
T_{STG}	Storage Temperature	-65 to +150	$^\circ\text{C}$

THERMAL DATA

$R_{th(j-c)}$	Junction -Case Thermal Resistance	0.35	$^\circ\text{C/W}$
---------------	-----------------------------------	------	--------------------

ELECTRICAL SPECIFICATION ($T_{CASE} = 25^{\circ}C$)

STATIC

Symbol	Test Conditions		Min.	Typ.	Max.	Unit
$V_{(BR)DSS}$	$V_{GS} = 0\text{ V}$	$I_{DS} = 100\text{ mA}$	125			V
I_{DSS}	$V_{GS} = 0\text{ V}$	$V_{DS} = 50\text{ V}$			5	mA
I_{GSS}	$V_{GS} = 20\text{ V}$	$V_{DS} = 0\text{ V}$			5	μA
$V_{GS(Q)}$	$V_{DS} = 10\text{ V}$	$I_D = 250\text{ mA}$	1.5		4	V
$V_{DS(ON)}$	$V_{GS} = 10\text{ V}$	$I_D = 10\text{ A}$			3	V
G_{FS}	$V_{DS} = 10\text{ V}$	$I_D = 5\text{ A}$	5			mho
C_{ISS}	$V_{GS} = 0\text{ V}$	$V_{DS} = 50\text{ V}$		480		pF
C_{OSS}	$V_{GS} = 0\text{ V}$	$V_{DS} = 50\text{ V}$		190		pF
C_{RSS}	$V_{GS} = 0\text{ V}$	$V_{DS} = 50\text{ V}$		18		pF

REF. 7163911B

DYNAMIC

Symbol	Test Conditions		Min.	Typ.	Max.	Unit
P_{OUT}	$V_{DD} = 50\text{ V}$	$I_{DQ} = 500\text{ mA}$ $f = 175\text{ MHz}$	300			W
G_{PS}	$V_{DD} = 50\text{ V}$	$I_{DQ} = 500\text{ mA}$ $P_{OUT} = 300\text{ W}$ $f = 175\text{ MHz}$	15	16		dB
η_D	$V_{DD} = 50\text{ V}$	$I_{DQ} = 500\text{ mA}$ $P_{OUT} = 300\text{ W}$ $f = 175\text{ MHz}$	50	60		%
Load Mismatch	$V_{DD} = 50\text{ V}$	$I_{DQ} = 500\text{ mA}$ $P_{OUT} = 300\text{ W}$ $f = 175\text{ MHz}$ All Phase Angles	5:1			VSWR

IMPEDANCE DATA

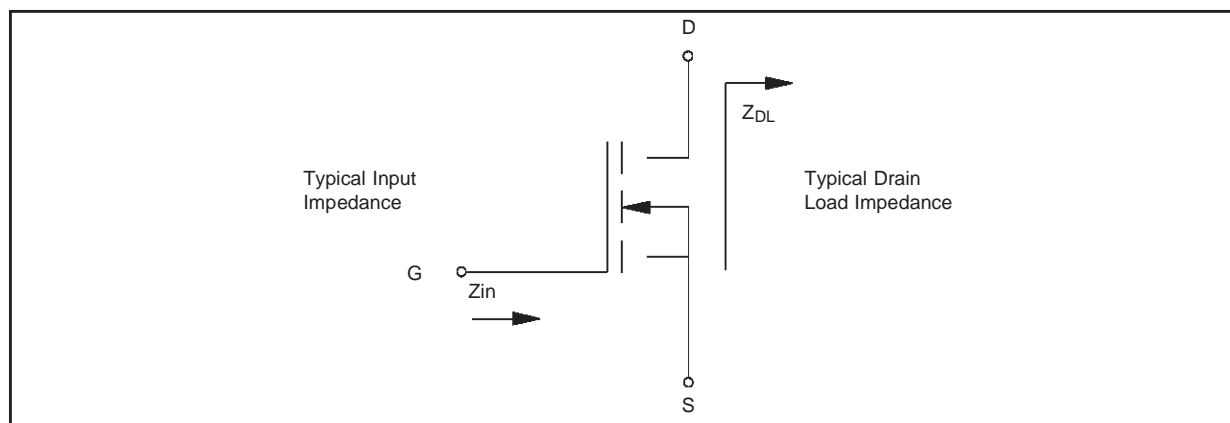

FREQ	$Z_{IN} (\Omega)$	$Z_{DL} (\Omega)$
175 MHz	$0.92 - j 0.14$	$3.17 + j 4.34$

Measured Gate to Gate and Drain to Drain, respectively.

TYPICAL PERFORMANCE

Maximum Thermal Resistance vs. Case Temperature

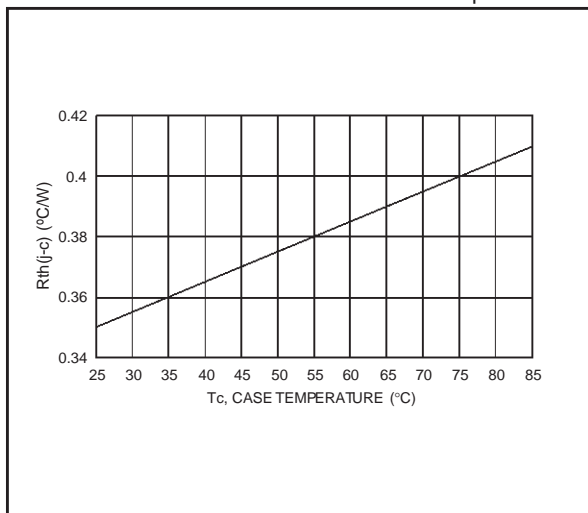

Safe Operating Area

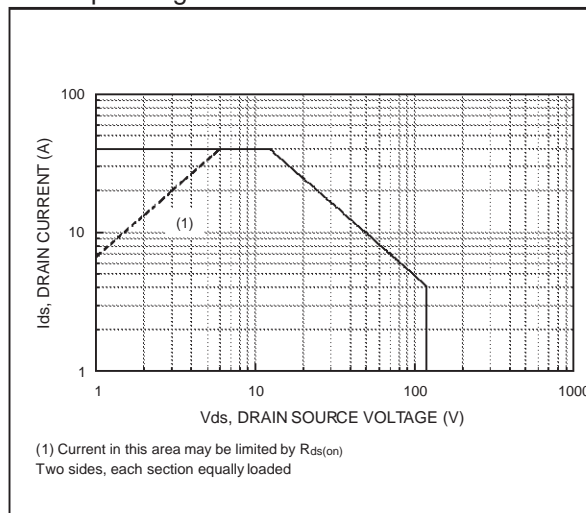

Capacitance vs. Drain-Source Voltage

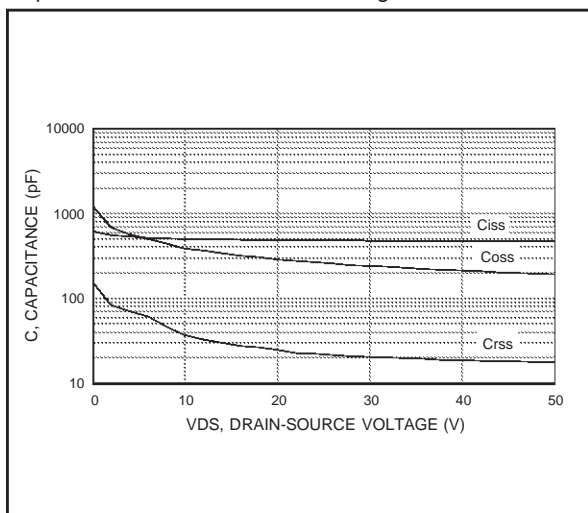

Drain Current vs. Gate Voltage

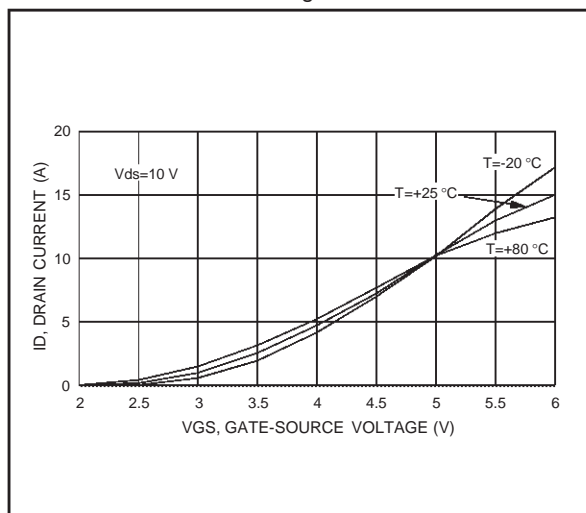

Gate Voltage vs. Case Temperature

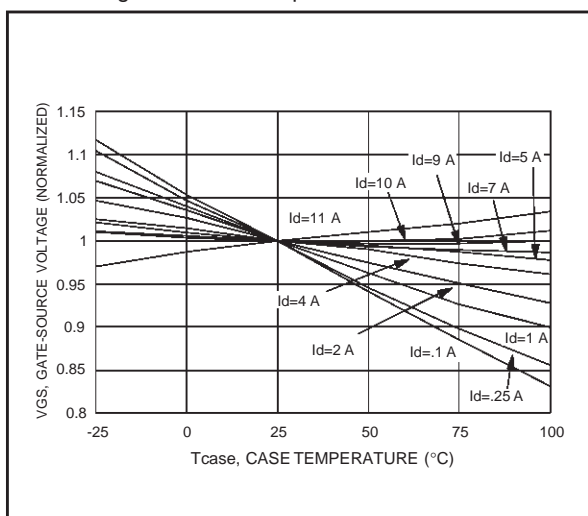

SD2932

TYPICAL PERFORMANCE (175 MHz)

Output Power vs. Input Power

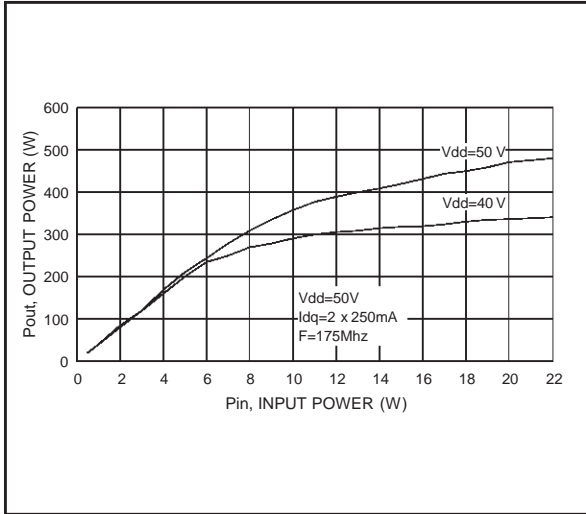

Output Power vs. Input Power

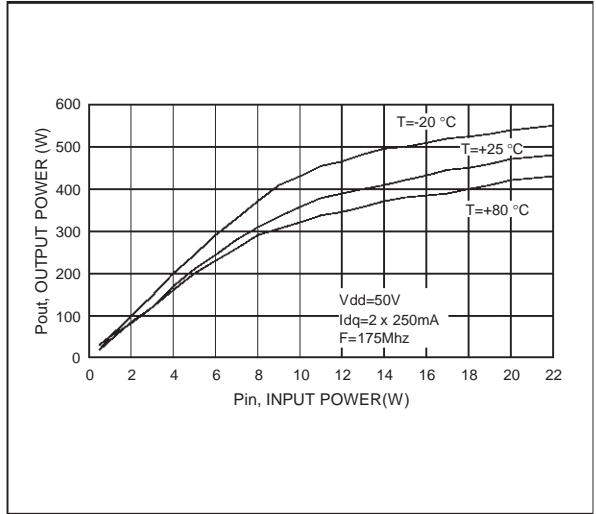

Power Gain vs. Output Power

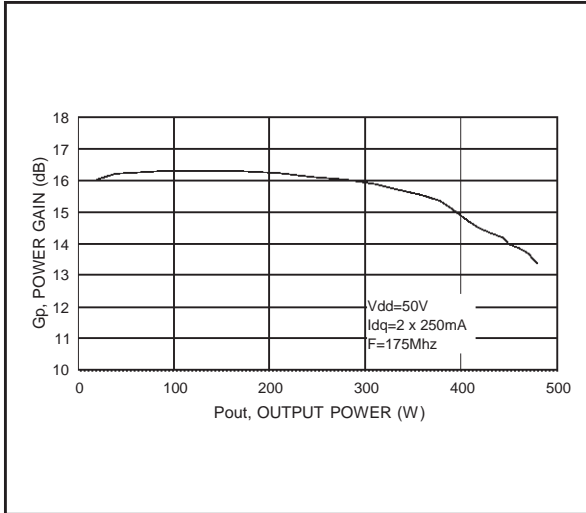

Efficiency vs. Output Power

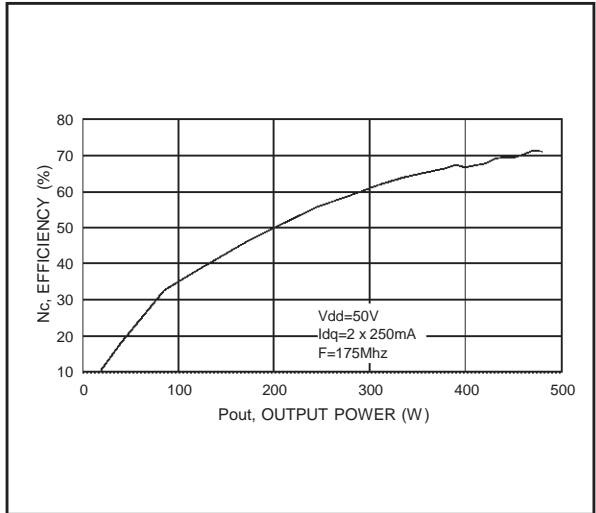

Output Power vs. Supply Voltage

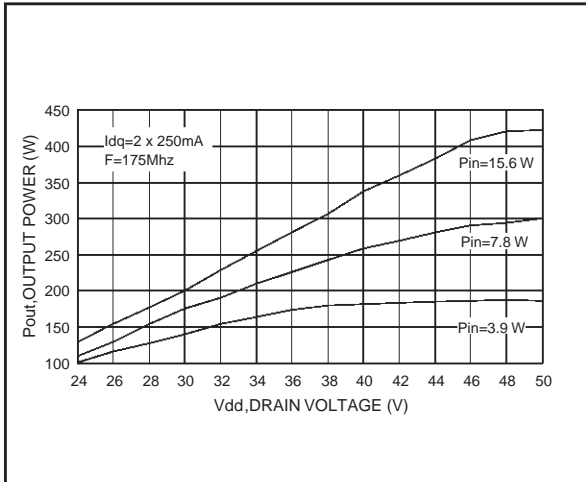

Output Power vs. Gate Voltage

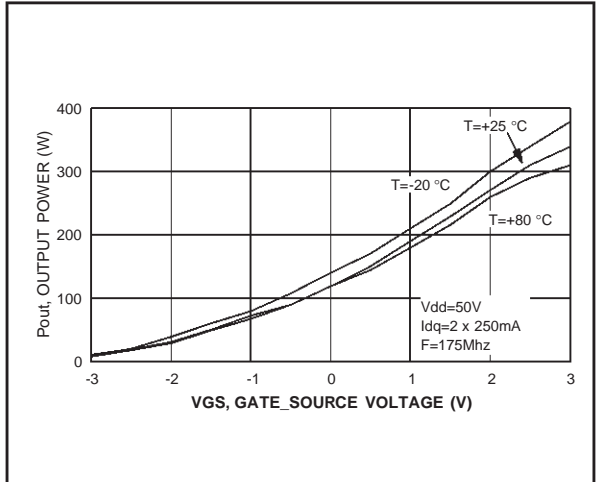

175 MHz Test Circuit Schematic (Production Test Circuit)

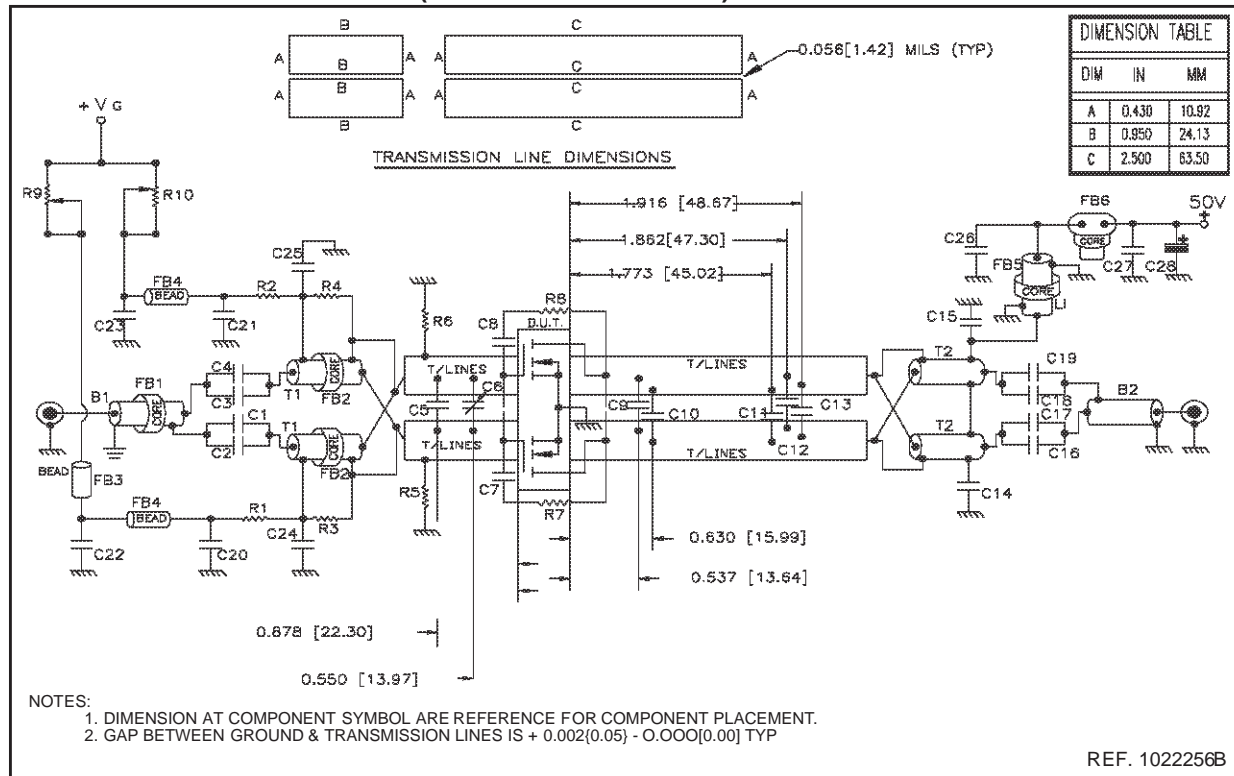

175 MHz Test Circuit Component Part List

R1,R2,R5,R6	470 Ohm 1 W, Surface Mount Chip Resistor
R3,R4	360 Ohm 0.5 W, Carbon Comp. Axial Lead Resistor or Equivalent
R7,R8	560 Ohm 2 W, Resistor Two Turn Wire Air-Wound Axial Lead Resistor
R9,R10	20 K Ohm 3.09 W, 10 Turn Wirewound Precision Potentiometer
C1,C4	680 pF ATC 130B Surface Mount Ceramic Chip Capacitor
C2,C3,C7,C8,C17,C19,C20,C21	10000 pF ATC 200B Surface Mount Ceramic Chip Capacitor
C5	75 pF ATC 100B Surface Mount Ceramic Chip Capacitor
C6	ST40 25 pF - 115 pF Miniature variable Trimmer
C9,C10	47 pF ATC 100B Surface Mount Ceramic Chip Capacitor
C11,C12, C13	43 pF ATC 100B Surface Mount Ceramic Chip Capacitor
C14,C15,C24,C25	1200 pF ATC 700B Surface Mount Ceramic Chip Capacitor
C16,C18	470 pF ATC 700B Surface Mount Ceramic Chip Capacitor
C22,C23	0.1 μ F / 500 V Surface Mount Ceramic Chip Capacitor
C26,C27	0.01 μ F / 500 V Surface Mount Ceramic Chip Capacitor
C28	10 μ F / 63 Aluminum Electrolytic Axial Lead Capacitor
B1	50 Ohm RG316 O.D 0.076[1.93] L = 11.80[299.72] Flexible Coaxial Cable 4 Turns thru Fair-rite Bead
B2	50 Ohm RG-142B O.D 0.165[4.19] L = 11.80[299.72] Flexible Coaxial Cable
T1	R.F. Transformer 4:1, 25 Ohm O.D RG316-25 O.D 0.080[2.03] L = 5.90[149.86] Flexible Coaxial Cable 2 Turns thru Fair-rite Multi-Aperture Core
T2	R.F. Transformer 1:4, 25 Ohm Semi-rigid Coaxial Cable O.D. 0.141[3.58] L = 5.90[149.86]
L1	Inductor λ 1/4 Wave 50 Ohm O.D 0.165[4.19] L = 11.80 [299.72] Flexible Coaxial Cable 2 Turns thru Fair-rite Bead
FB1,FB5	Shield Bead
FB2,FB6	Multi-aperture Core
FB3	Multilayer Ferrite Chip Bead (Surface Mount)
FB4	Surface Mount Emi Shield Bead
PCB	Woven Glass Reinforced PTFE Microwave Laminate 0.06", 1 oz EDCu, Both sides, $\epsilon_r = 2.55$

175 MHz Test Circuit Photomaster

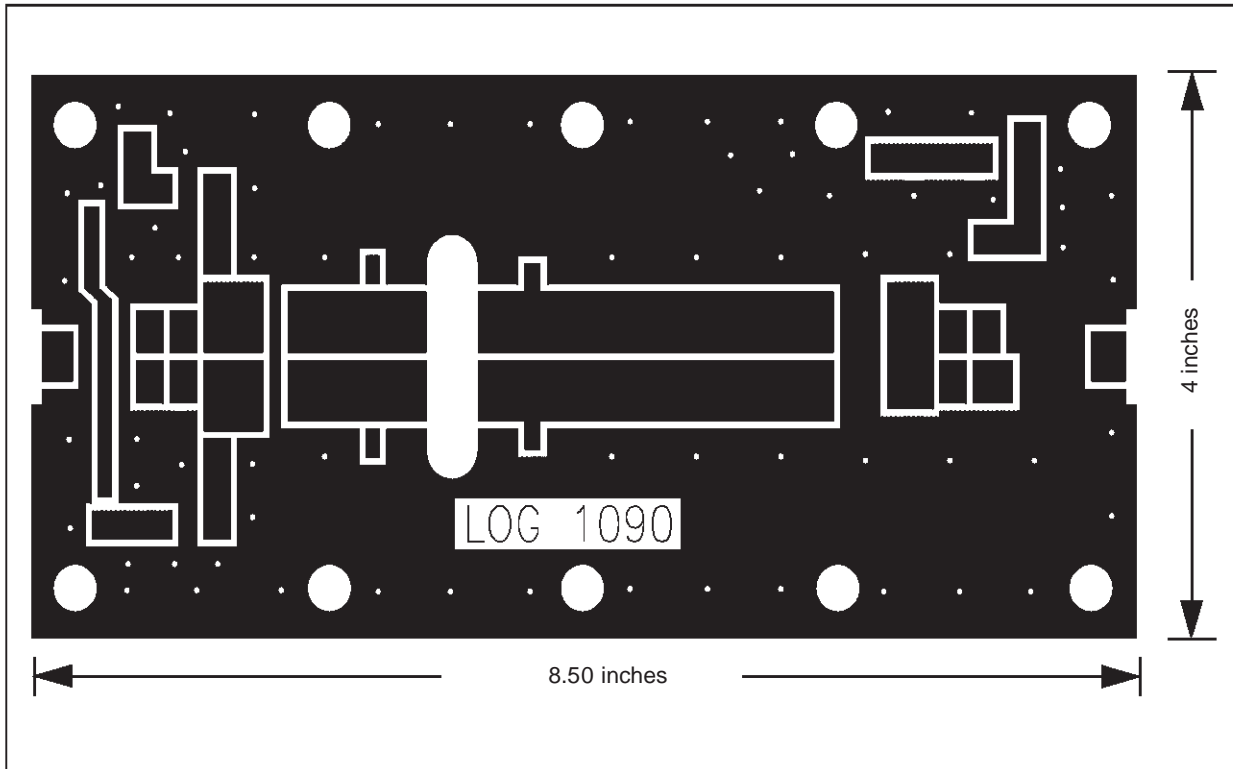

175 MHz Test Fixture

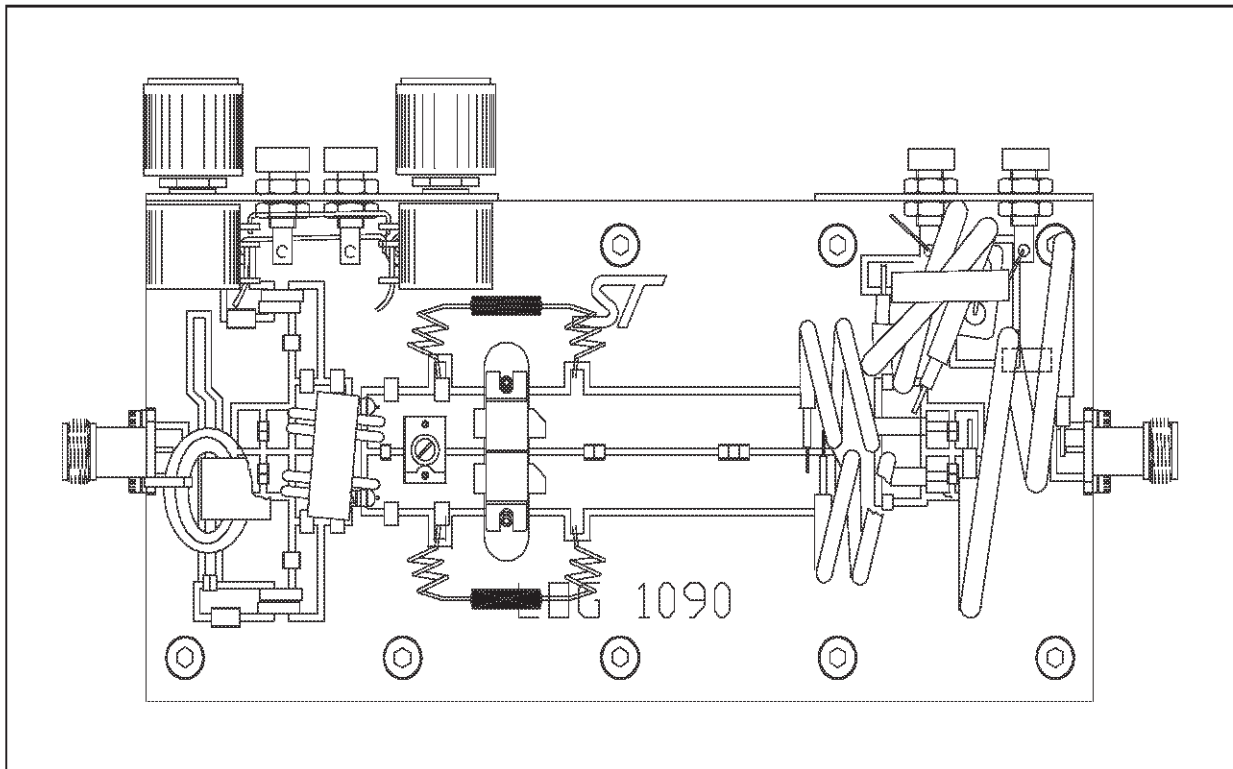

TYPICAL BROADBAND DATA (175 - 230 MHz)

Input Power vs. Frequency

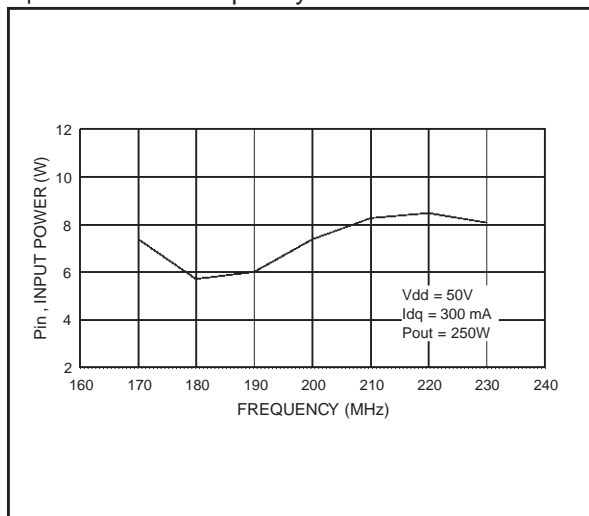

Power Gain vs. Frequency

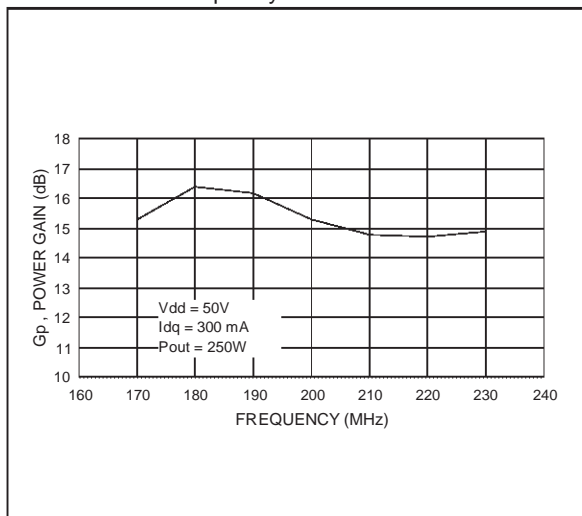

Efficiency vs. Frequency

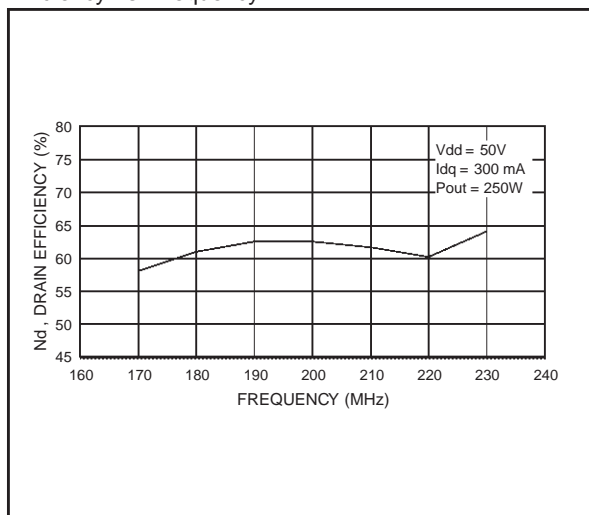

Return Loss vs. Frequency

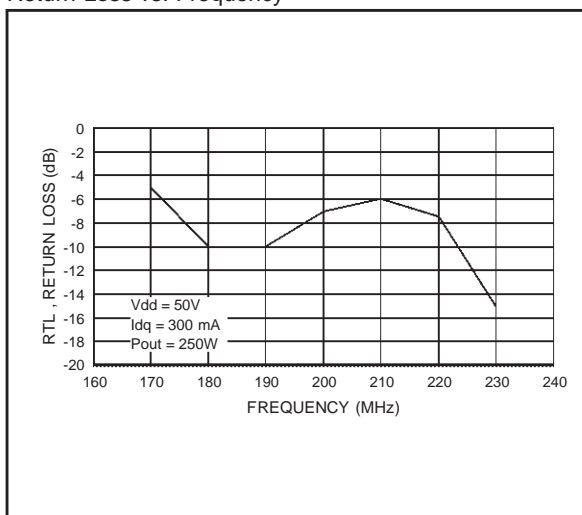

1 dB Compression Point vs. Frequency

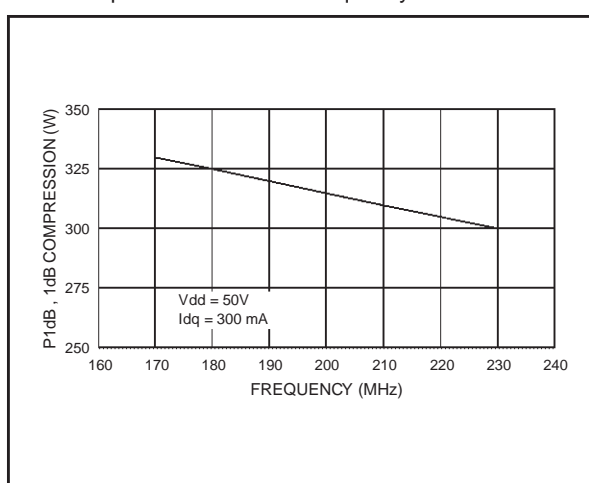

175 - 230 MHz Test Circuit Layout (Engineering Fixture)

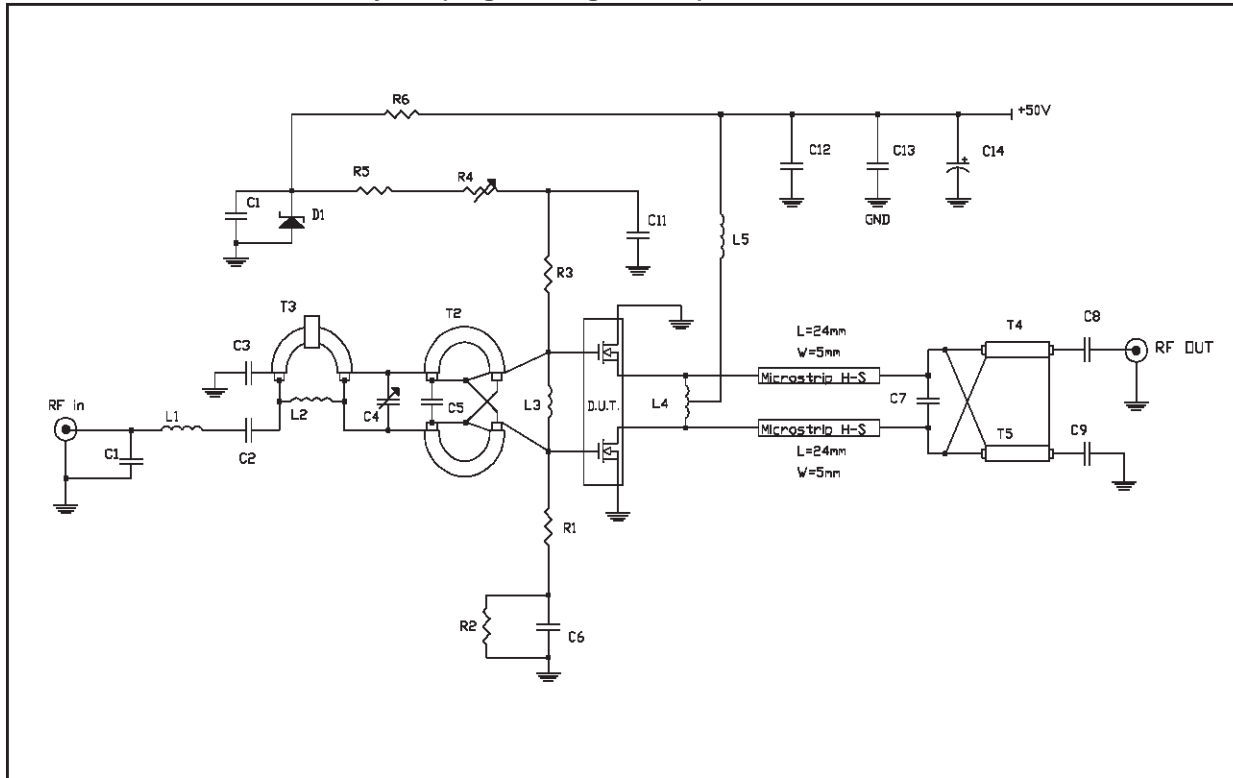

175 - 230 MHz Circuit Layout Component Part List

PCB	1/32" Woven Fiberglass 0.030 Cu, sides, $\epsilon_r = 4.8$
T1	50 Ohm Flexible Coax Cable OD 0.06", 3" Long. Ferrite Core NEOSIDE
T2,T3	9:1 Transformer, 16.5 Ohm Flexible Coax Cable 0.1", 3" Long
T4,T5	4:1 Transformer, 25 Ohm Flexible Coax Cable OD 0.06", 5" Long
C1	8.2 pF Ceramic Cap
C2,C3	100 pF Ceramic Cap
C4	2 - 18 pF Chip Cap
C5	47 pF Ceramic Cap
C6,C11	47 nF Ceramic Cap
C7	56 pF ATC Chip Cap
C8,C9,C13	470 pF ATC Chip Cap
C10	100 nF Ceramic Cap
C12	2 x 330 nF / 50 V Cap
C14	10 nF / 63 V Electrolytic Cap
R1,R3	47 Ohm Resistor
R2	6.8 K Ohm Chip Resistor
R4	4.7 K Ohm Multi Turns Trim Resistor
R5	8.2 K Ohm / 5 W Resistor
R6	3.3 K Ohm / 5 W Resistor
D1	6.8 V Zener Diode
L1	20 nH Inductor
L2	70 nH Inductor
L3	30 nH Inductor
L4	10 nH Inductor
L5	15 nH Inductor

TYPICAL BROADBAND DATA (88 - 108 MHz)

Input Power vs. Frequency

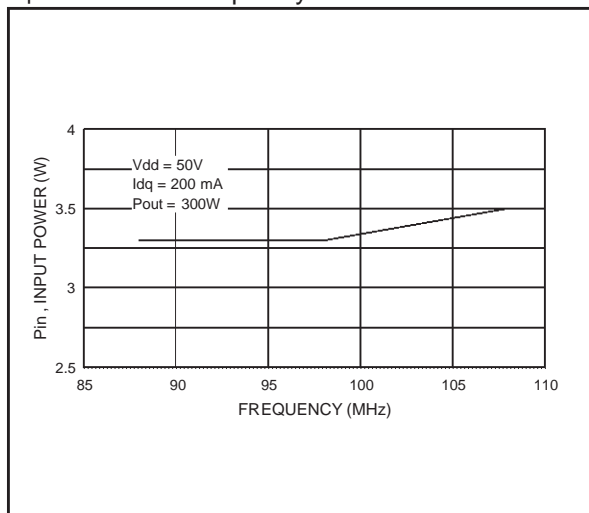

Power Gain vs. Frequency

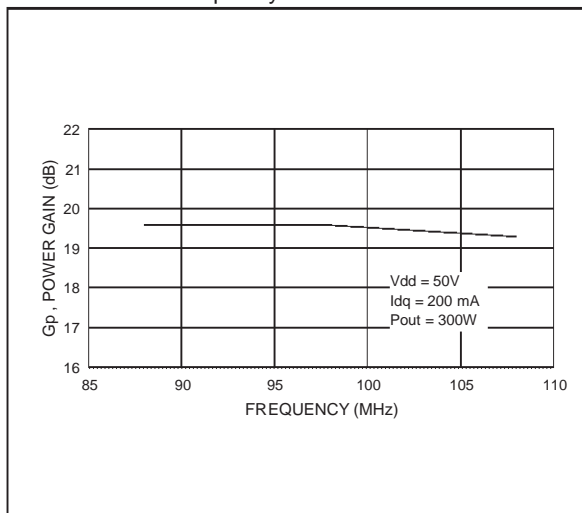

Efficiency vs. Frequency

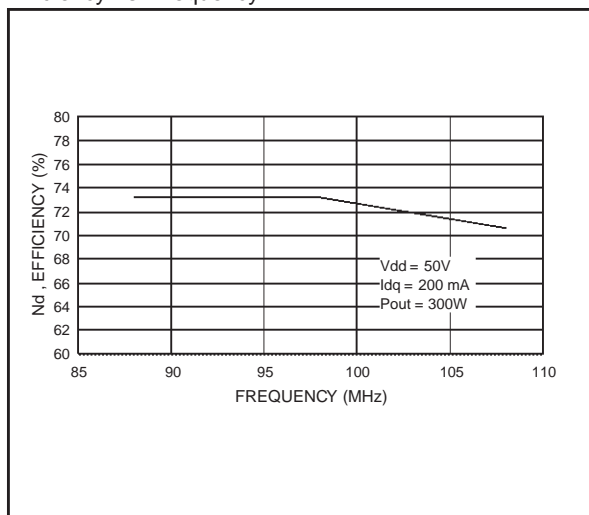

Return Loss vs. Frequency

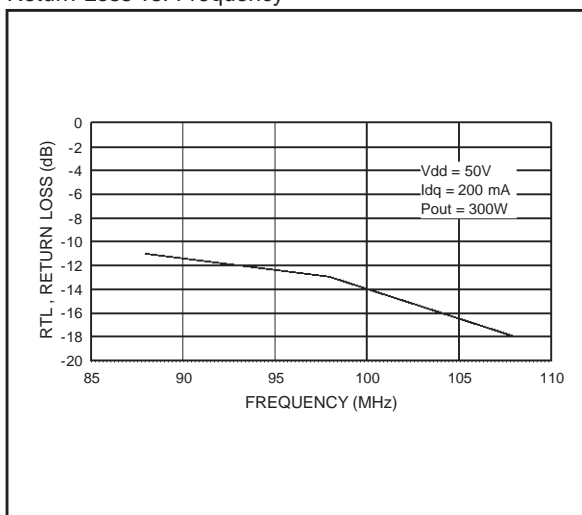

2nd Harmonic vs. Frequency (88 - 108 MHz)

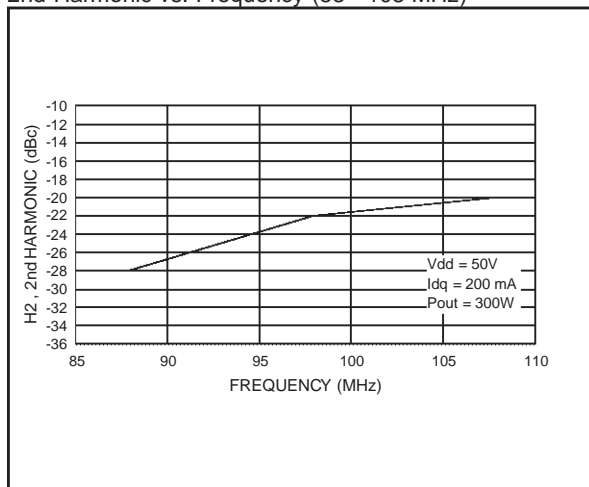

3rd Harmonic vs. Frequency (88 - 108 MHz)

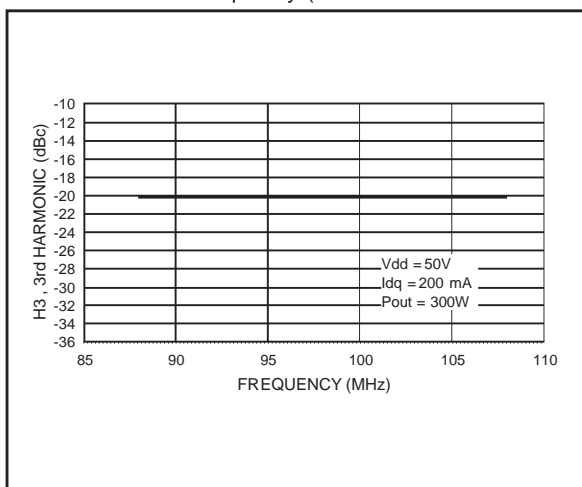

88 - 108 MHz Test Circuit Layout (Engineering Fixture)

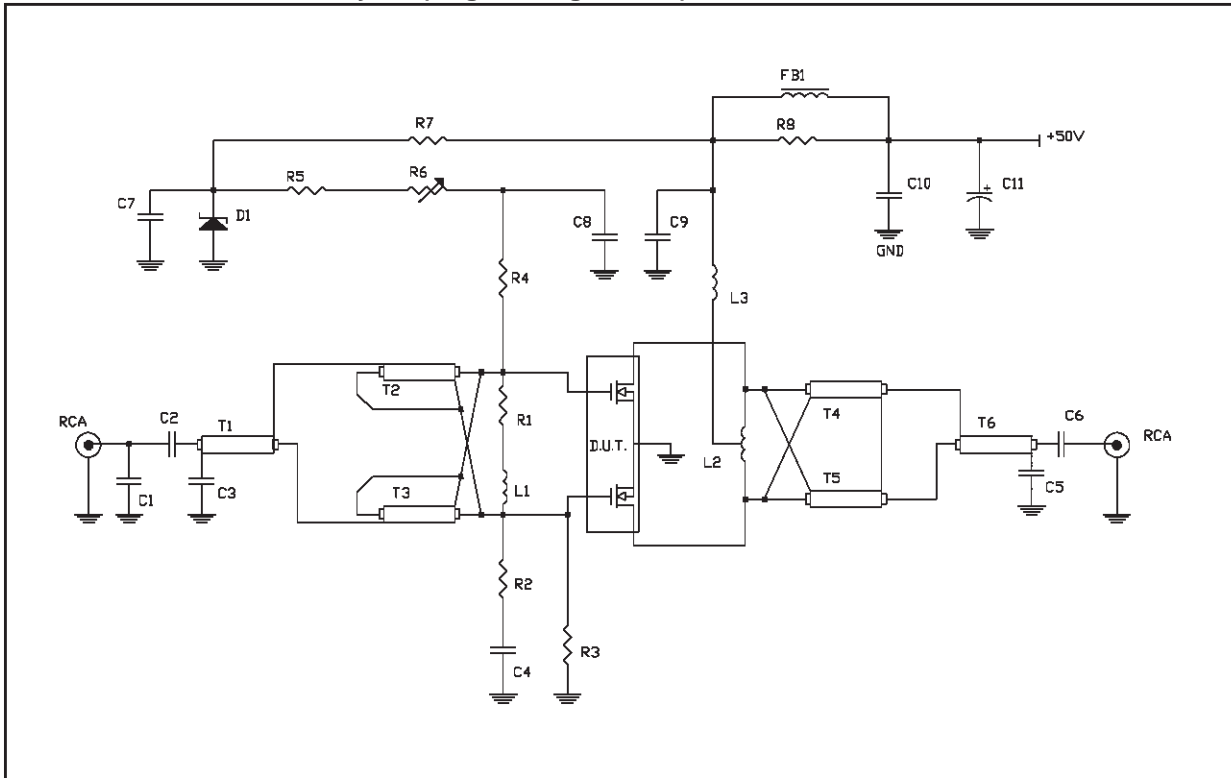

88 - 108 MHz Circuit Layout Component Part List

PCB	1/32" Woven FiberGlass 0.030 Cu, 2 sides, $\epsilon_r = 4.8$
T1	50 Ohm Flexible Coax Cable OD 0.06", 5" Long
T2,T3	9:1 Transformer, 25 Ohm Flexible Coax Cable OD 0.1", 3.9". Ferrite Core NEOSIDE
T4,T5	4:1 Transformer, 25 Ohm Flexible Coax Cable OD 0.1", 5" Long
T6	50 Ohm Flexible Coax Cable OD 0.1", 5" Long
FB1	vk200
C1	10 pF Ceramic Cap
C2,C3,C4,C7,C8	1 nF Chip Cap
C5,C6	1 nF ATC Chip Cap
C9	470 pF ATC Chip Cap
C10	100 nF Chip Cap
C11	100 mF / 63 V Electrolytic Cap
R1	56 Ohm Resistor
R2,R4	10 Ohm Chip Resistor
R3	10 K Ohm Resistor
R5	5.6 Ohm Resistor
R6	10 K Ohm, 10 Turn Trim Resistor
R7	3.3 K Ohm / 5 W Resistor
R8	15 Ohm / 5 W Resistor
D1	6.6 V Zener Diode
L1	10 nH Inductor
L2	40 nH Inductor
L3	70 nH Inductor

M244 (.400 x .860 4/L BAL N/HERM W/FLG) MECHANICAL DATA

DIM.	mm			Inch		
	MIN.	TYP.	MAX	MIN.	TYP.	MAX
A	5.59		5.84	0.220		0.230
B		5.08			0.200	
C	3.02		3.28	0.119		0.129
D	9.65		9.91	0.380		0.390
E	19.81		20.82	0.780		0.820
F	10.92		11.18	0.430		0.440
G		27.94			1.100	
H	33.91		34.16	1.335		1.345
I	0.10		0.15	0.004		0.006
J	1.52		1.78	0.060		0.070
K	2.59		2.84	0.102		0.112
L	4.83		5.84	0.190		0.230
M	10.03		10.34	0.395		0.407
N	21.59		22.10	0.850		0.870

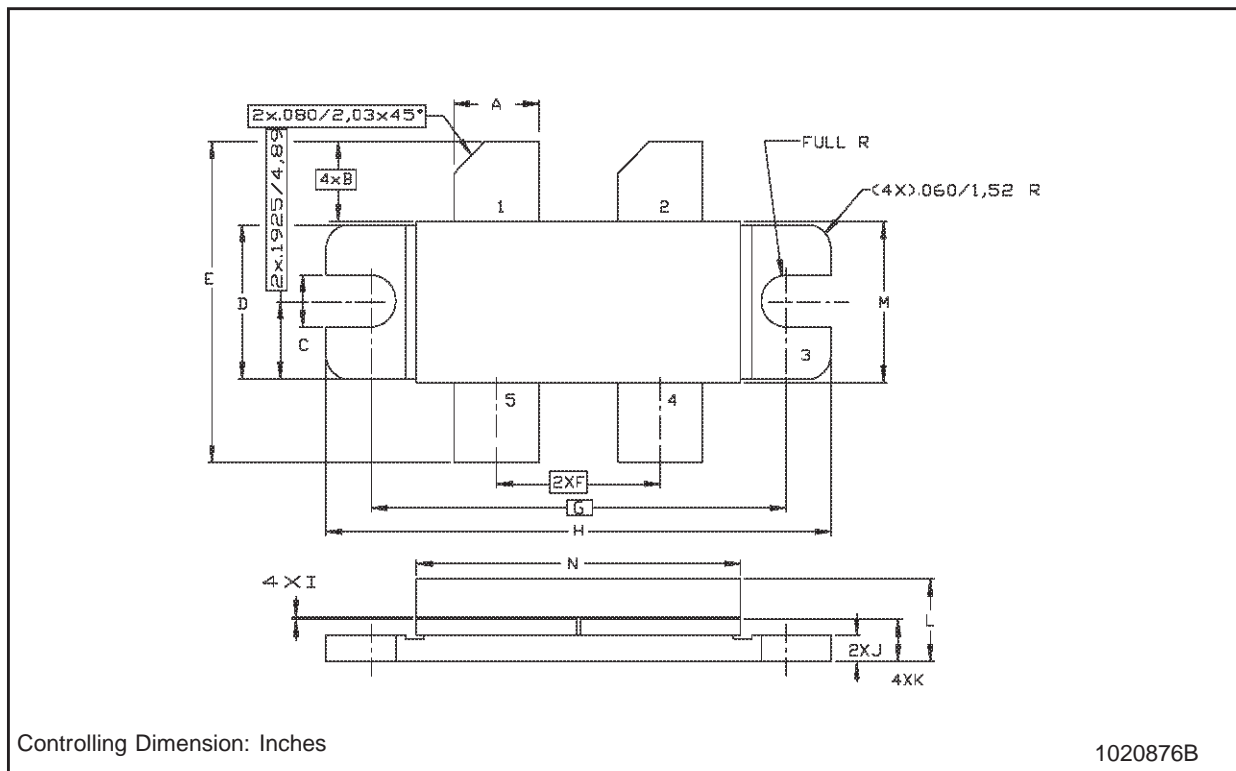

Information furnished is believed to be accurate and reliable. However, STMicroelectronics assumes no responsibility for the consequences of use of such information nor for any infringement of patents or other rights of third parties which may result from its use. No license is granted by implication or otherwise under any patent or patent rights of STMicroelectronics. Specifications mentioned in this publication are subject to change without notice. This publication supersedes and replaces all information previously supplied. STMicroelectronics products are not authorized for use as critical components in life support devices or systems without express written approval of STMicroelectronics.

The ST logo is registered trademark of STMicroelectronics
© 2000 STMicroelectronics - All Rights Reserved

All other names are the property of their respective owners.

STMicroelectronics GROUP OF COMPANIES
Australia - Brazil - China - Finland - France - Germany - Hong Kong - India - Italy - Japan - Malaysia - Malta - Morocco -
Singapore - Spain - Sweden - Switzerland - United Kingdom - U.S.A.

<http://www.st.com>