



SD57030

RF POWER TRANSISTORS

The *LdmoST* FAMILY

ADVANCE DATA

N-CHANNEL ENHANCEMENT-MODE LATERAL MOSFETs

- EXCELLENT THERMAL STABILITY
- COMMON SOURCE CONFIGURATION
- $P_{OUT} = 30$ W WITH 13 dB gain @ 945 MHz
- BeO FREE PACKAGE

DESCRIPTION

The SD57030 is a common source N-Channel enhancement-mode lateral Field-Effect RF power transistor designed for broadband commercial and industrial applications at frequencies up to 1.0 GHz. The SD57030 is designed for high gain and broadband performance operating in common source mode at 28 V. It is ideal for base station applications requiring high linearity.

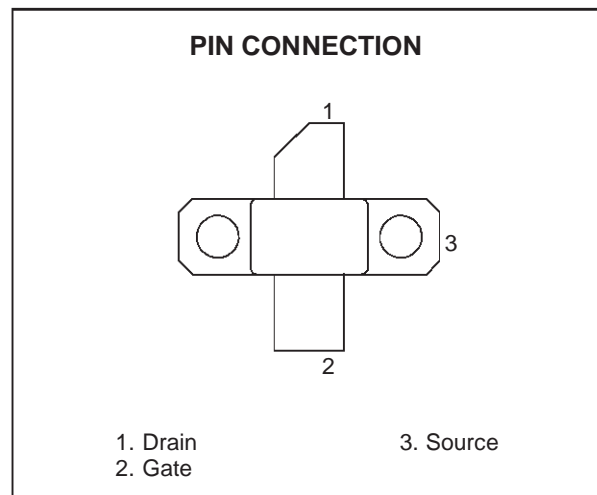
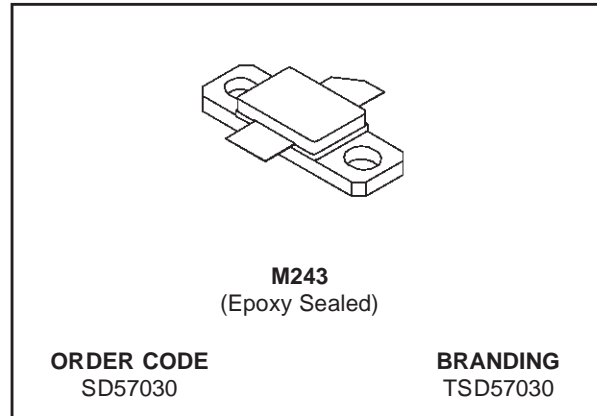

ABSOLUTE MAXIMUM RATINGS ($T_{CASE} = 25^{\circ}C$)

Symbol	Parameter	Value	Unit
$V_{(BR)DSS}$	Drain-Source Voltage	65	V
V_{DGR}	Drain-Gate Voltage ($R_{GS} = 1 M\Omega$)	65	V
V_{GS}	Gate-Source Voltage	+ 20	V
I_D	Drain Current	4	A
P_{DISS}	Power Dissipation (@ $T_c = 70^{\circ}C$)	74	W
T_j	Max. Operating Junction Temperature	200	$^{\circ}C$
T_{STG}	Storage Temperature	-65 to + 200	$^{\circ}C$

THERMAL DATA

$R_{th(j-c)}$	Junction -Case Thermal Resistance	1.75	$^{\circ}C/W$
---------------	-----------------------------------	------	---------------

ELECTRICAL SPECIFICATION ($T_{CASE} = 25^{\circ}C$)

STATIC

Symbol	Test Conditions		Min.	Typ.	Max.	Unit
$V_{(BR)DSS}$	$V_{GS} = 0 V$	$I_{DS} = 10 mA$	65			V
I_{DSS}	$V_{GS} = 0 V$	$V_{DS} = 28 V$			1	μA
I_{GSS}	$V_{GS} = 20 V$	$V_{DS} = 0 V$			1	μA
$V_{GS(Q)}$	$V_{DS} = 28 V$	$I_D = 50 mA$	2.0		5.0	V
$V_{DS(ON)}$	$V_{GS} = 10 V$	$I_D = 3 A$		1.3		V
G_{FS}	$V_{DS} = 10 V$	$I_D = 3 A$		1.8		mho
C_{ISS}^*	$V_{GS} = 0 V$	$V_{DS} = 28 V$		58		pF
C_{OSS}	$V_{GS} = 0 V$	$V_{DS} = 28 V$		34		pF
C_{RSS}	$V_{GS} = 0 V$	$V_{DS} = 28 V$		2.7		pF

Ref. 7143417B

DYNAMIC

Symbol	Test Conditions		Min.	Typ.	Max.	Unit
P_{OUT}	$V_{DD} = 28 V$	$I_{DQ} = 50 mA$	30			W
G_{PS}	$V_{DD} = 28 V$	$I_{DQ} = 50 mA$	13	15		dB
η_D	$V_{DD} = 28 V$	$I_{DQ} = 50 mA$	50	60		%
Load mismatch	$V_{DD} = 28 V$	$I_{DQ} = 50 mA$	10:1			VSWR

TYPICAL PERFORMANCE (CW)

Output Power vs. Input Power

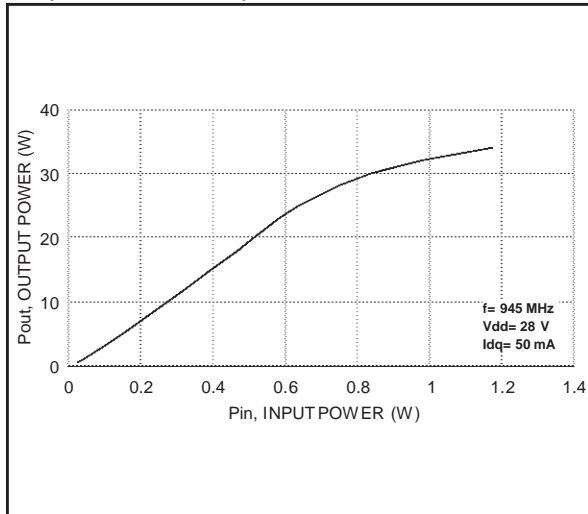

Power Gain and Efficiency vs. Output Power

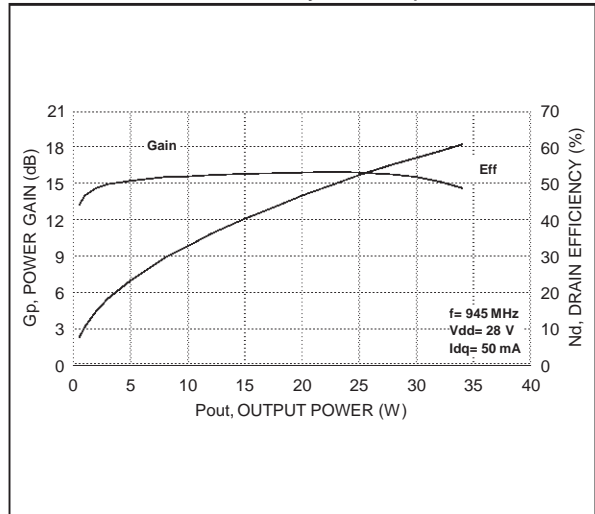

Output Power vs. Gate Source Voltage

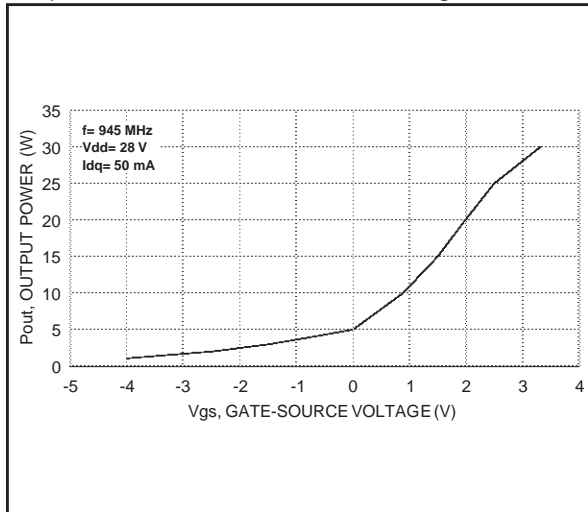

Output Power vs. Supply Voltage

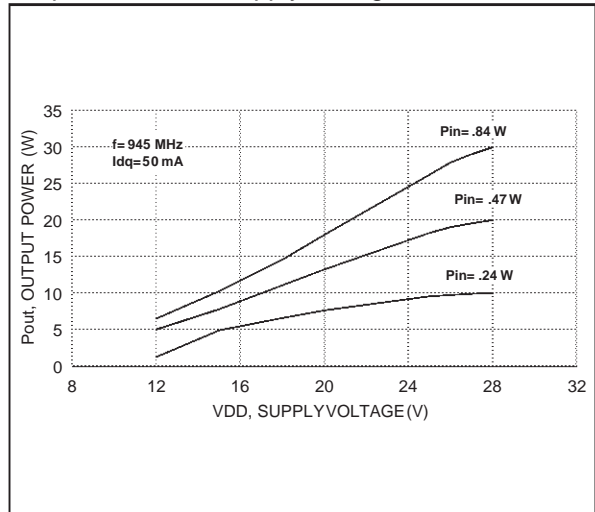

TEST CIRCUIT SCHEMATIC

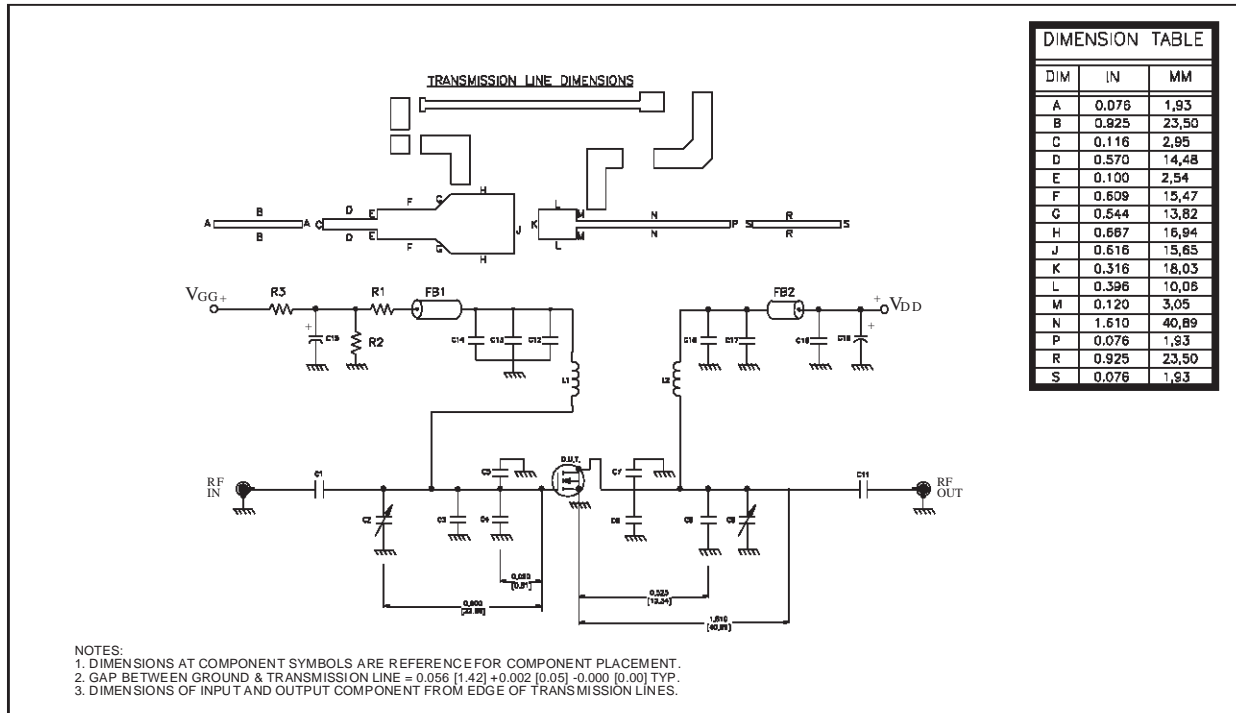

TEST CIRCUIT COMPONENT PART LIST

COMPONENT	DESCRIPTION
C19	200 μF / 63V ALLUMINIUM ELECTROLYTIC RADIAL LEAD CAPACITOR
C18, C14	0.1 μF / 500V SURFACE MOUNT CERAMIC CHIP CAPACITOR
C17	100 pF ATC 100B SURFACE MOUNT CERAMIC CHIP CAPACITOR
C16, C12, C11, C1	47 pF ATC 100B SURFACE MOUNT CERAMIC CHIP CAPACITOR
C15	10 μF / 50V ALUMINIUM ELECTROLYTIC RADIAL LEAD CAPACITOR
C13	100 pF ATC 700B SURFACE MOUNT CERAMIC CHIP CAPACITOR
C9, C2	0.8-8.0 pF GIGA TRIM VARIABLE CAPACITOR
C8	6.2 pF ATC 100B SURFACE MOUNT CERAMIC CHIP CAPACITOR
C7, C6, C5, C4	10 pF ATC 100B SURFACE MOUNT CERAMIC CHIP CAPACITOR
C3	3 pF ATC 100B SURFACE MOUNT CERAMIC CHIP CAPACITOR
R3	120 0-IM, 2W SURFACE MOUNT CERAMIC CHIP CAPACITOR
R2	4.7 M OHM 1W SURFACE MOUNT CERAMIC CHIP CAPACITOR
R1	18 K OHM, 1W SURFACE MOUNT CERAMIC CHIP CAPACITOR
FB2, FB1	SHIELD BEAD SURFACE MOUNT EMI
L2, L1	INDUCTOR, 5 TURNS AIR WOUND #22AWG, ID=0.059[1.49], NYLON COATED MAGNET WIRE
PCB	WOVEN FIBERGLASS REINFORCED PTFE 0.080" THK, εr=2.55, 2 Oz EDCu BOTH SIDE

TEST CIRCUIT

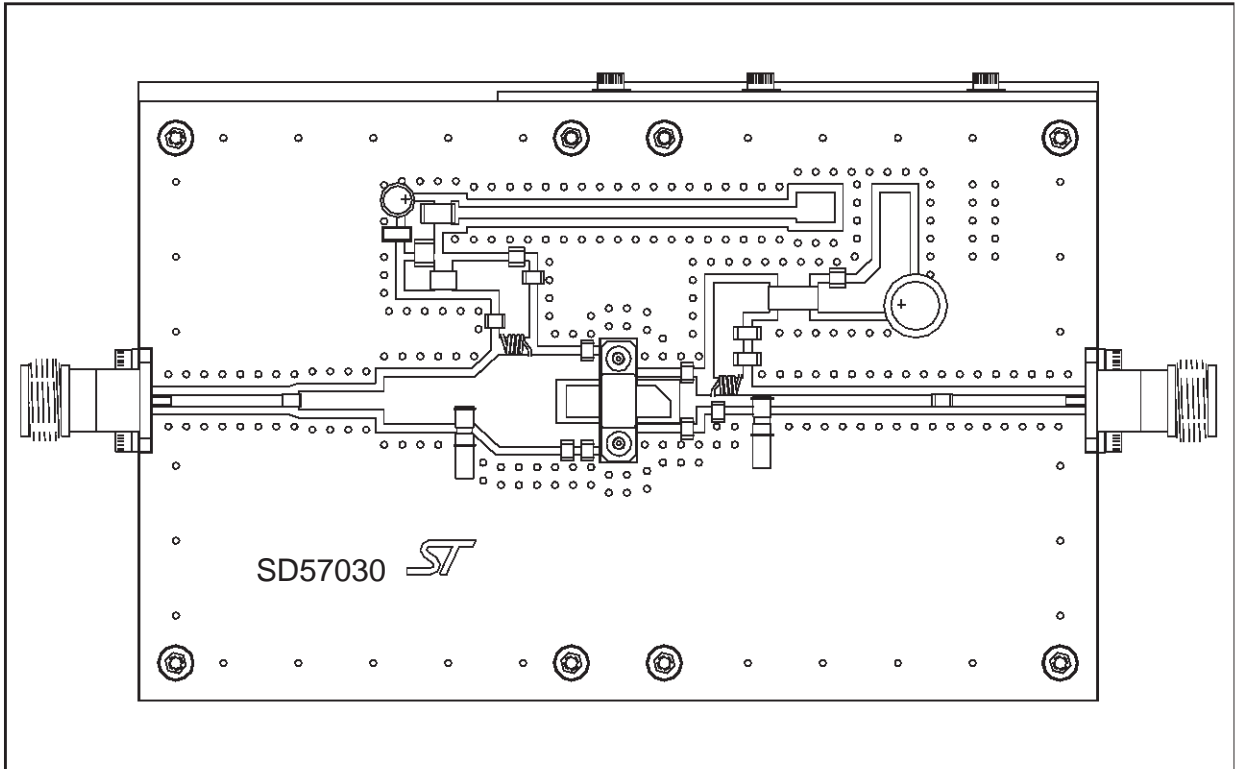

TEST CIRCUIT PHOTOMASTER

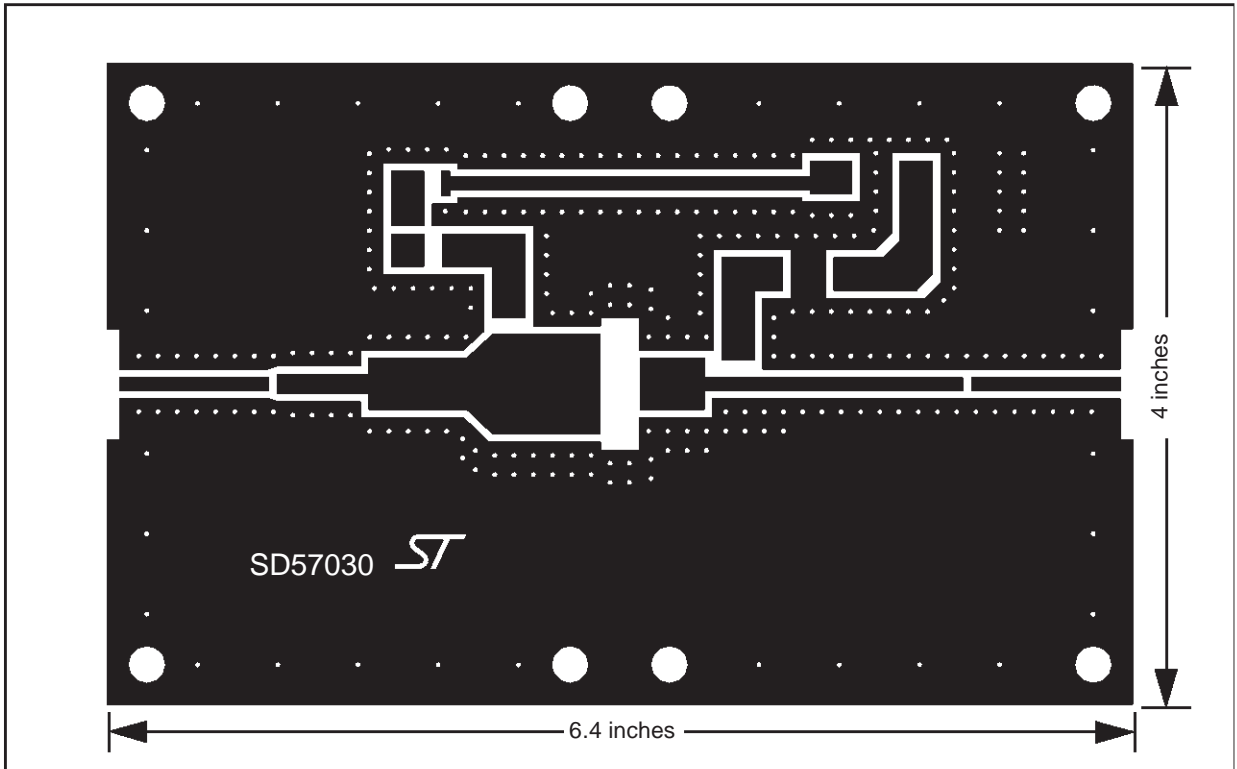

M243 (.230 x .360 2L N/HERM W/FLG) MECHANICAL DATA

DIM.	mm			Inch		
	MIN.	TYP.	MAX	MIN.	TYP.	MAX
A	5.21		5.72	0.205		0.225
B	5.46		6.48	0.215		0.255
C	5.59		6.10	0.220		0.240
D		14.27			0.562	
E	20.07		20.57	0.790		0.810
F	8.89		9.40	0.350		0.370
G	0.10		0.15	0.004		0.006
H	3.18		4.45	0.125		0.175
I	1.83		2.24	0.072		0.088
J	1.27		1.78	0.050		0.070

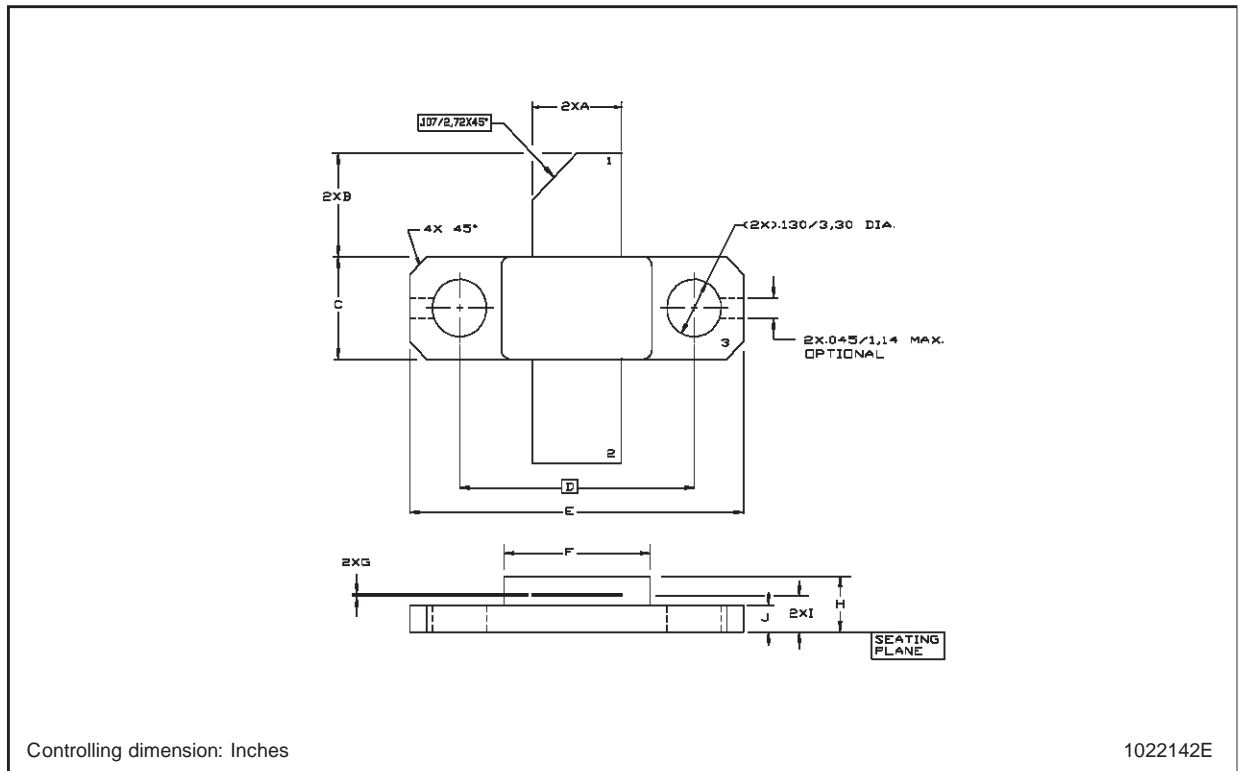

Information furnished is believed to be accurate and reliable. However, STMicroelectronics assumes no responsibility for the consequences of use of such information nor for any infringement of patents or other rights of third parties which may result from its use. No license is granted by implication or otherwise under any patent or patent rights of STMicroelectronics. Specifications mentioned in this publication are subject to change without notice. This publication supersedes and replaces all information previously supplied. STMicroelectronics products are not authorized for use as critical components in life support devices or systems without express written approval of STMicroelectronics.

The ST logo is registered trademark of STMicroelectronics
© 2001 STMicroelectronics - All Rights Reserved

All other names are the property of their respective owners.

STMicroelectronics GROUP OF COMPANIES
Australia - Brazil - China - Finland - France - Germany - Hong Kong - India - Italy - Japan - Malaysia - Malta - Morocco -
Singapore - Spain - Sweden - Switzerland - United Kingdom - U.S.A.

<http://www.st.com>