



ST13007D

HIGH VOLTAGE FAST-SWITCHING NPN POWER TRANSISTOR

- IMPROVED SPECIFICATION:
 - LOWER LEAKAGE CURRENT
 - TIGHTER GAIN RANGE
 - DC CURRENT GAIN PRESELECTION
 - TIGHTER STORAGE TIME RANGE
- HIGH VOLTAGE CAPABILITY
- INTEGRATED FREE-WHEELING DIODE
- LOW SPREAD OF DYNAMIC PARAMETERS
- MINIMUM LOT-TO-LOT SPREAD FOR RELIABLE OPERATION
- VERY HIGH SWITCHING SPEED
- FULLY CHARACTERIZED AT 125 °C
- LARGE RBSOA

APPLICATIONS

- UP TO 120W ELECTRONIC TRANSFORMERS FOR HALOGEN LAMPS
- SWITCH MODE POWER SUPPLIES

DESCRIPTION

The device is manufactured using high voltage Multi Epitaxial Planar technology for high switching speeds and high voltage capability. It uses a Cellular Emitter structure to enhance switching speeds.

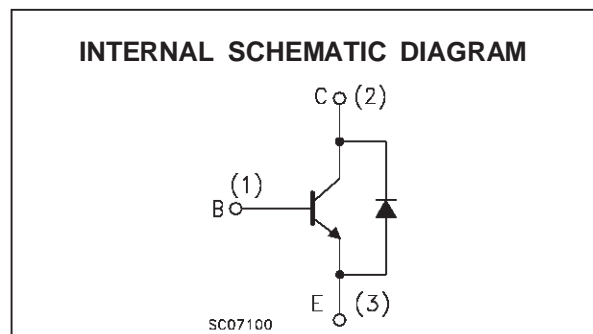
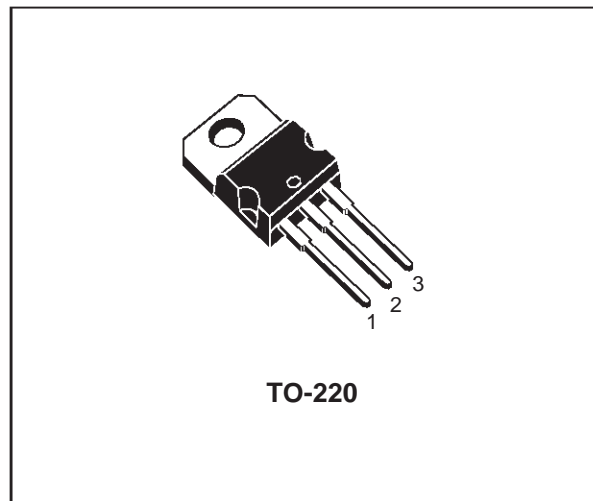

ABSOLUTE MAXIMUM RATINGS

Symbol	Parameter	Value	Unit
V_{CEV}	Collector-Emitter Voltage ($V_{BE} = -1.5V$)	700	V
V_{CEO}	Collector-Emitter Voltage ($I_B = 0$)	400	V
V_{EBO}	Emitter-Base Voltage ($I_C = 0$)	9	V
I_C	Collector Current	8	A
I_{CM}	Collector Peak Current	16	A
I_B	Base Current	4	A
I_{BM}	Base Peak Current	8	A
P_{tot}	Total Dissipation at $T_c \leq 25\text{ }^\circ\text{C}$	80	W
T_{stg}	Storage Temperature	-65 to 150	$^\circ\text{C}$
T_j	Max. Operating Junction Temperature	150	$^\circ\text{C}$

THERMAL DATA

R _{thj-case}	Thermal Resistance Junction-case	Max	1.56	°C/W
R _{thj-amb}	Thermal Resistance Junction-ambient	Max	62.5	°C/W

ELECTRICAL CHARACTERISTICS (T_{case} = 25 °C unless otherwise specified)

Symbol	Parameter	Test Conditions	Min.	Typ.	Max.	Unit
I _{CES}	Collector Cut-off Current (V _{BE} = 0)	V _{CE} = 700 V V _{CE} = 700 V T _c = 100 °C			10 0.5	μA mA
I _{CEO}	Collector Cut-off Current (I _B = 0)	V _{CE} = 400 V			100	μA
I _{EBO}	Emitter Cut-off Current (I _C = 0)	V _{EB} = 9 V			100	μA
V _{CEO(sus)*}	Collector-Emitter Sustaining Voltage (I _B = 0)	I _C = 10 mA	400			V
V _{CE(sat)*}	Collector-Emitter Saturation Voltage	I _C = 2 A I _B = 0.4 A I _C = 5 A I _B = 1 A I _C = 8 A I _B = 2 A I _C = 5 A I _B = 1 A T _c = 100 °C			0.8 1.5 2 3	V V V V
V _{BE(sat)*}	Base-Emitter Saturation Voltage	I _C = 2 A I _B = 0.4 A I _C = 5 A I _B = 1 A I _C = 5 A I _B = 1 A T _c = 100 °C			1.2 1.6 1.5	V V V
h _{FE*}	DC Current Gain	I _C = 2 A V _{CE} = 5 V I _C = 5 A V _{CE} = 5 V	18 8		40 25	
V _f	Diode Forward Voltage	I _C = 3 A			2.5	V
t _s t _f	INDUCTIVE LOAD Storage Time Fall Time	I _C = 5 A V _{CL} = 250 V R _{BB} = 0Ω I _{B1} = 1 A V _{BE(off)} = -5 V L = 200 μH (see figure 1)		0.8 40	1.6 100	μs ns
t _s t _f	INDUCTIVE LOAD Storage Time Fall Time	I _C = 5 A V _{CL} = 250 V R _{BB} = 0Ω I _{B1} = 1 A V _{BE(off)} = -5 V L = 200 μH T _C = 125 °C (see figure 1)		1.1 80		μs ns

* Pulsed: Pulse duration = 300 μs, duty cycle 2 %.

Safe Operating Area

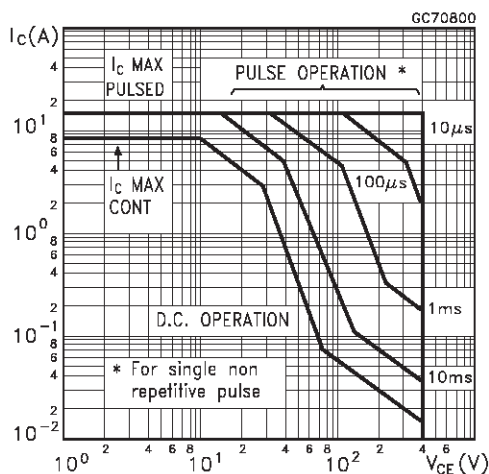

Derating Curve

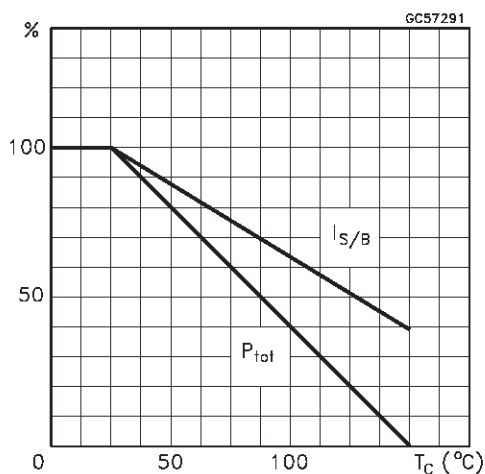

DC Current Gain

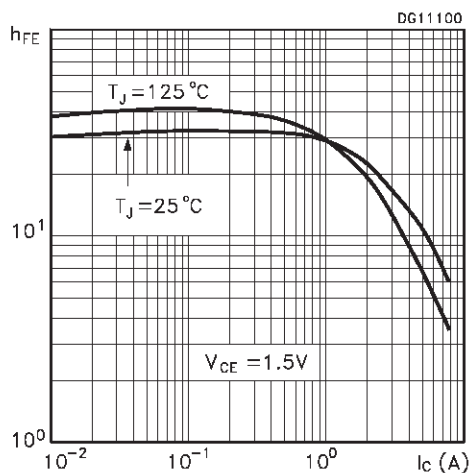

DC Current Gain

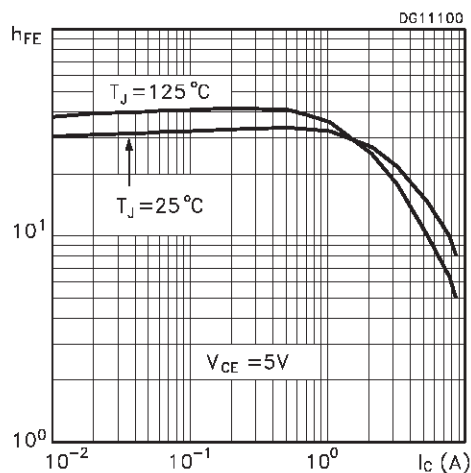

Collector Emitter Saturation Voltage

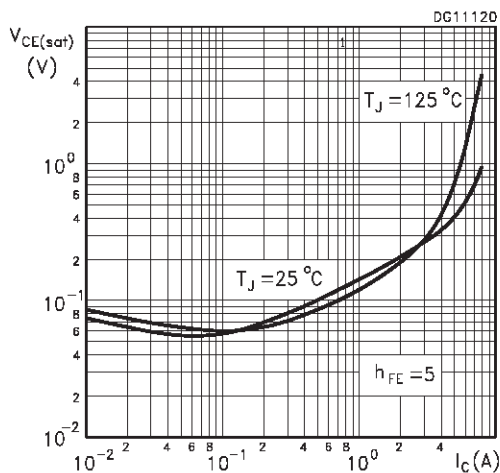

Base Emitter Saturation Voltage

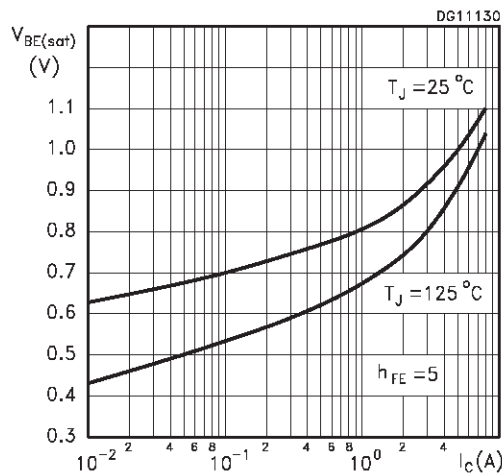

Diode Forward Voltage

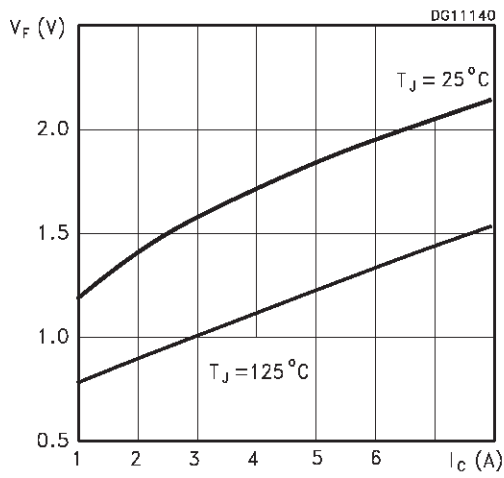

Switching Time Resistive Load

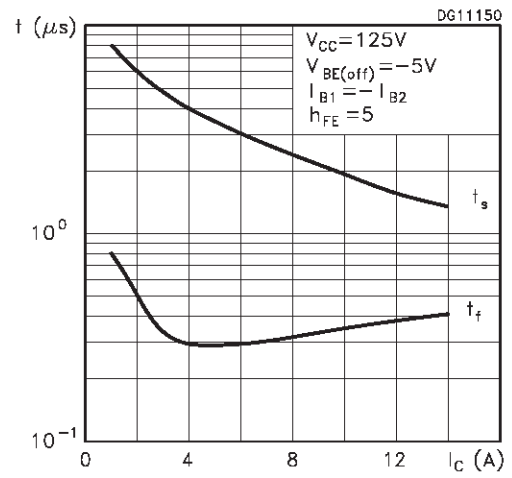

Switching Time Inductive Load

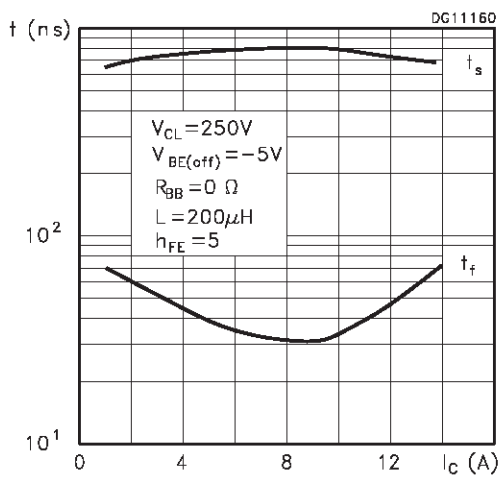

Reverse Biased SOA

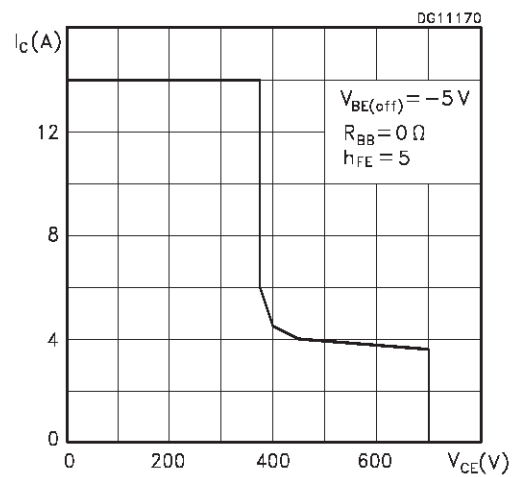

Figure 1: Inductive Load Switching Test Circuit.

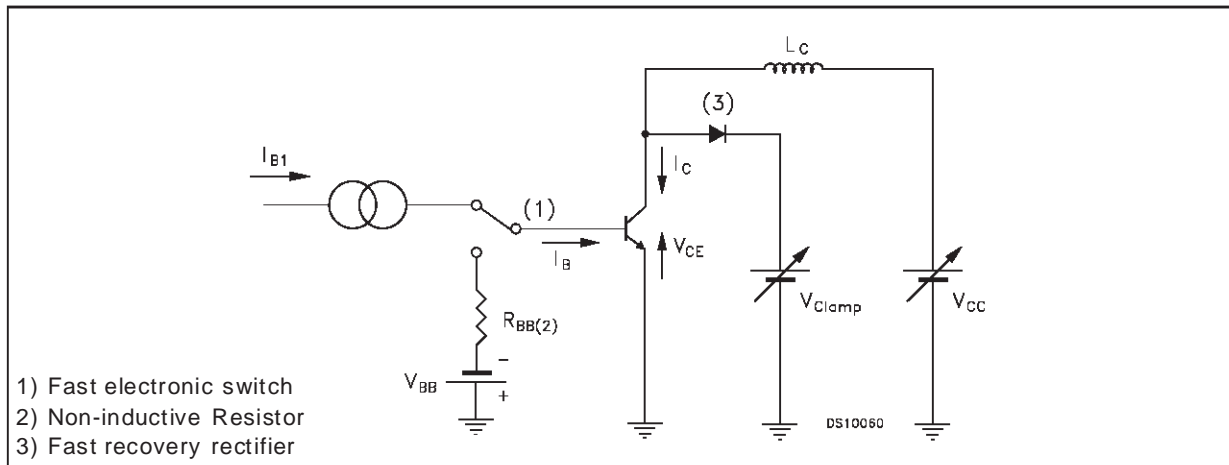
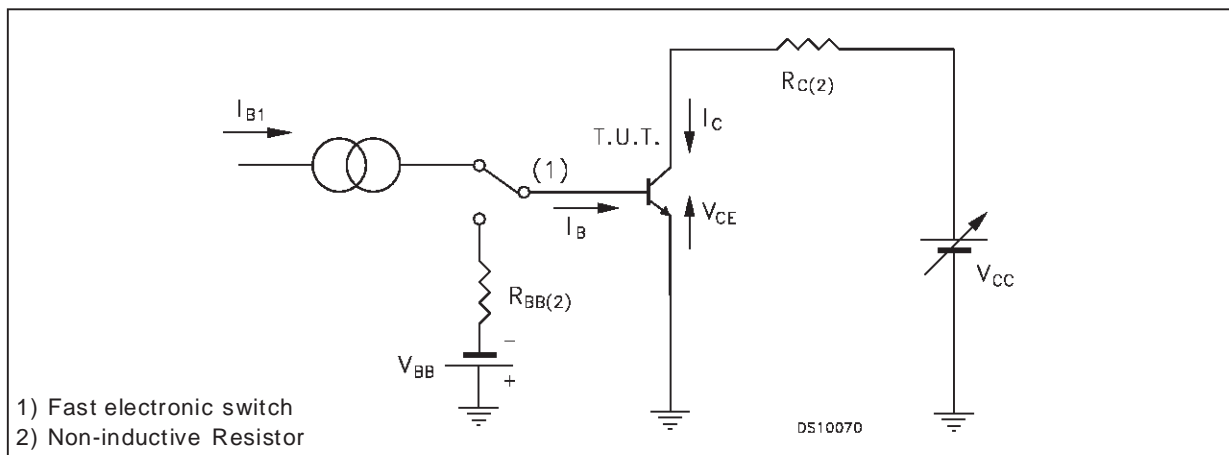
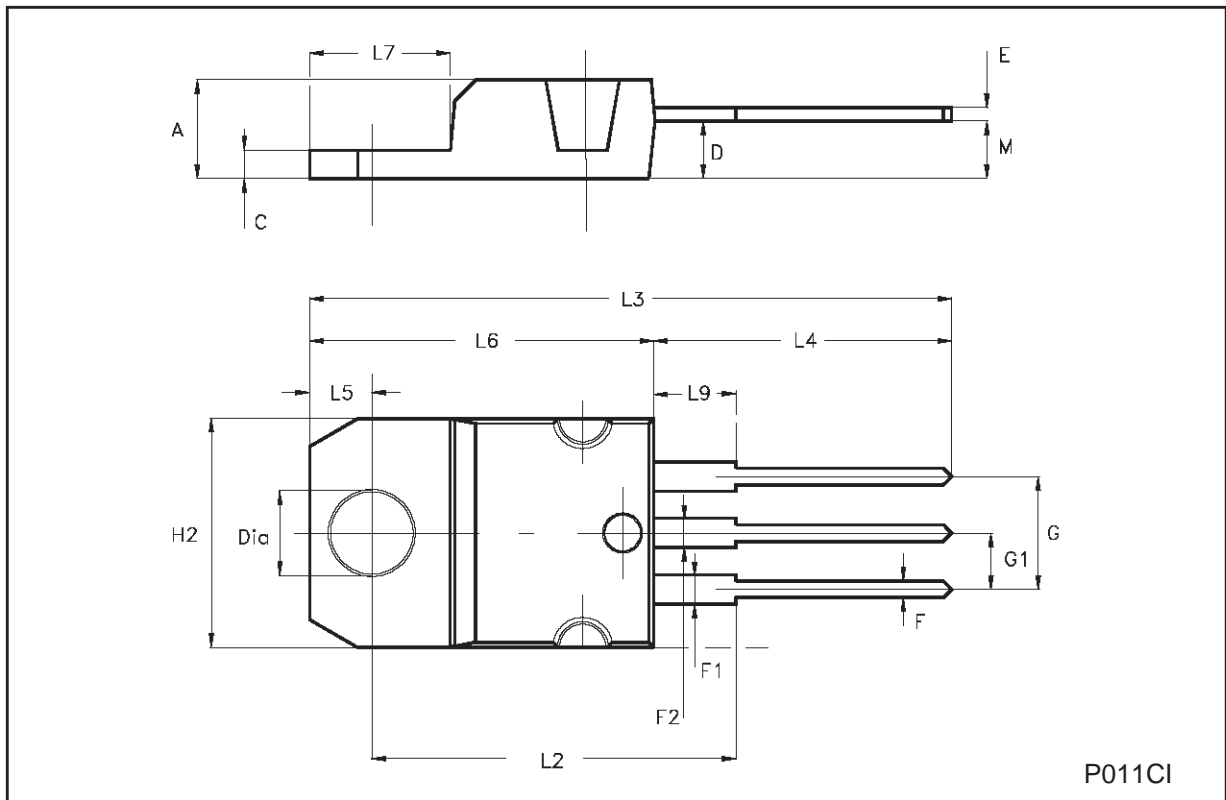

Figure 2: Resistive Load Switching Test Circuit.



TO-220 MECHANICAL DATA

DIM.	mm			inch		
	MIN.	TYP.	MAX.	MIN.	TYP.	MAX.
A	4.40		4.60	0.173		0.181
C	1.23		1.32	0.048		0.052
D	2.40		2.72	0.094		0.107
E	0.49		0.70	0.019		0.027
F	0.61		0.88	0.024		0.034
F1	1.14		1.70	0.044		0.067
F2	1.14		1.70	0.044		0.067
G	4.95		5.15	0.194		0.202
G1	2.40		2.70	0.094		0.106
H2	10.00		10.40	0.394		0.409
L2		16.40			0.645	
L4	13.00		14.00	0.511		0.551
L5	2.65		2.95	0.104		0.116
L6	15.25		15.75	0.600		0.620
L7	6.20		6.60	0.244		0.260
L9	3.50		3.93	0.137		0.154
M		2.60			0.102	
DIA.	3.75		3.85	0.147		0.151



Information furnished is believed to be accurate and reliable. However, STMicroelectronics assumes no responsibility for the consequences of use of such information nor for any infringement of patents or other rights of third parties which may result from its use. No license is granted by implication or otherwise under any patent or patent rights of STMicroelectronics. Specification mentioned in this publication are subject to change without notice. This publication supersedes and replaces all information previously supplied. STMicroelectronics products are not authorized for use as critical components in life support devices or systems without express written approval of STMicroelectronics.

The ST logo is a trademark of STMicroelectronics

© 2002 STMicroelectronics – Printed in Italy – All Rights Reserved

STMicroelectronics GROUP OF COMPANIES

Australia - Brazil - Canada - China - Finland - France - Germany - Hong Kong - India - Israel - Italy - Japan - Malaysia - Malta - Morocco - Singapore - Spain - Sweden - Switzerland - United Kingdom - United States.

<http://www.st.com>

