



ST207EH

± 15KV ESD PROTECTED 5V HIGH PERFORMANCE RS-232 TRANSCEIVER

- SINGLE +5v SUPPLY OPERATION
- 0.1µF EXTENAL CHARGE PUMP CAPACITORS
- 500kbps DATE RATE UNDER LOAD
- LOWER SUPPLY CURRENT 1.5mA (TYP)
- IDEAL FOR HIGH SPEED RS-232 APPLICATIONS
- PACKAGED IN SO-24, SSO-24 AND TSSOP24
- ESD PROTECTION FOR RS-232 I/O PINS:
±15 KV HUMAN BODY MODEL

DESCRIPTION

The ST207EH is a high speed enhanced multi-channel RS-232 line transceivers with improved electrical performance. The ST207EH is a superior drop-in replacement to our previous versions as well as popular industry standards. The device feature low-power CMOS construction and the charge pump circuitry that generates the ±10V RS-232 voltag elevels using 01µF charges pump capacitors. The ST207EH include a high transmission rate of 500Kbps, a lower supply current at 1.5mA typical (no load), and a superior ESD performance. The ESD tolerance has been

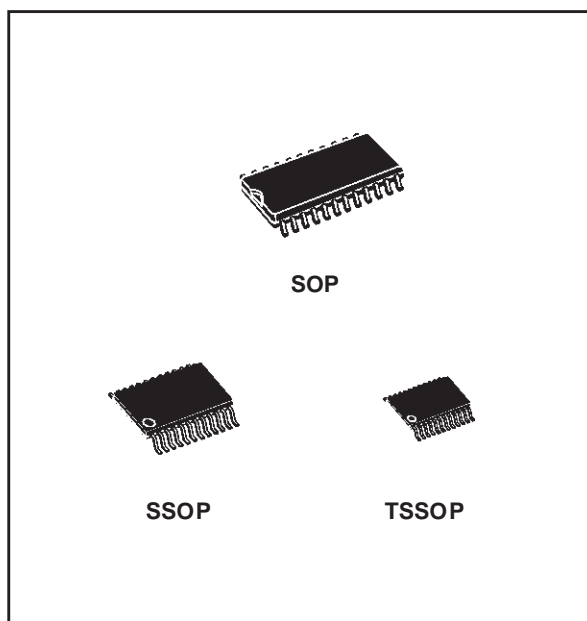

improved for this device over ±15KV for HUMAN Body Model. The ST207EH comes in 24-pin SO, SSO and TSSOP packages.

ORDERING CODES

Type	Temperature Range	Package	Comments
ST207EHCD	0 to 70 °C	SO-24 (Tube)	33parts per tube / 25tube per box
ST207EHBD	-40 to 85 °C	SO-24 (Tube)	33parts per tube / 25tube per box
ST207EHCDR	0 to 70 °C	SO-24 (Tape & Reel)	1000 parts per reel
ST207EHBDR	-40 to 85 °C	SO-24 (Tape & Reel)	1000 parts per reel
ST207EHCPR	0 to 70 °C	SSOP-24 (Tape & Reel)	1350 parts per reel
ST207EHBDR	-40 to 85 °C	SSOP-24 (Tape & Reel)	1350 parts per reel
ST207EHCTR	0 to 70 °C	TSSOP24 (Tape & Reel)	2500 parts per reel
ST207EBTR	-40 to 85 °C	TSSOP24 (Tape & Reel)	2500 parts per reel

PIN CONFIGURATION

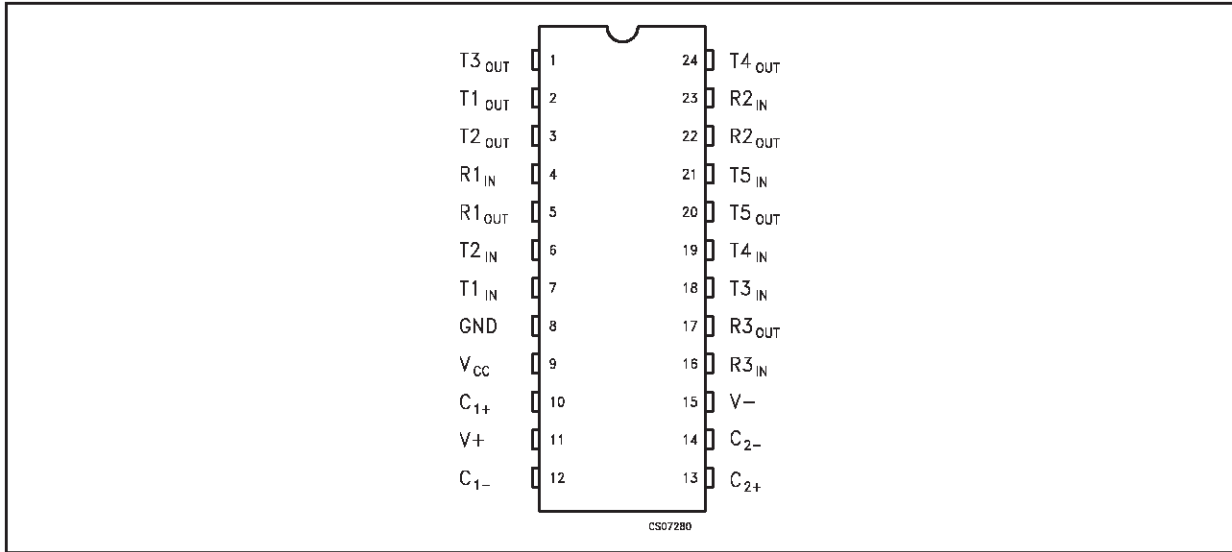

PIN DESCRIPTION

PIN N°	SYMBOL	NAME AND FUNCTION
1	T3 _{OUT}	RS-232 Driver Output
2	T1 _{OUT}	RS-232 Driver Output
3	T2 _{OUT}	RS-232 Driver Output
4	R1 _{IN}	RS-232 Receiver Input
5	R1 _{OUT}	TTL/CMOS Receiver Output
6	T2 _{IN}	TTL/CMOS Driver Input Internal Pull-up to V _{CC}
7	T1 _{IN}	TTL/CMOS Driver Input Internal Pull-up to V _{CC}
8	GND	Ground
9	V _{CC}	4.75V to 5.25V Supply Voltage
10	C ₁₊	Terminal For Positive Charge-pump Capacitor
11	V ₊	2V _{CC} Generated by The Charge-pump
12	C ₁₋	Terminal For Negative Charge-pump Capacitor
13	C ₂₊	Terminal For Positive Charge-pump Capacitor
14	C ₂₋	Terminal For Negative Charge-pump Capacitor
15	V ₋	-2V _{CC} Generated by The Charge-pump
16	R3 _{IN}	RS-232 Receiver Input
17	R3 _{OUT}	TTL/CMOS Receiver Output
18	T3 _{IN}	TTL/CMOS Driver Input Internal Pull-up to V _{CC}
19	T4 _{IN}	TTL/CMOS Driver Input Internal Pull-up to V _{CC}
20	T5 _{OUT}	RS-232 Driver Output
21	T5 _{IN}	TTL/CMOS Driver Input Internal Pull-up to V _{CC}
22	R2 _{OUT}	TTL/CMOS Receiver Output
23	R2 _{IN}	RS-232 Receiver Input
24	T4 _{OUT}	RS-232 Driver Output

ABSOLUTE MAXIMUM RATINGS

Symbol	Parameter	Value	Unit
V_{CC}	Supply Voltage	6	V
V+	Extra Positive Voltage	$(V_{CC} - 0.3)$ to 13.2	V
V-	Extra Negative Voltage	13.2	V
T_{IN}	Transmitter Input Voltage Range	-0.3 to $(V_{CC} + 0.3)$	V
R_{IN}	Receiver Input Voltage Range	± 20	V
T_{OUT}	Transmitter Output Voltage Range	$(V_{-} - 0.3)$ to $(V_{+} + 0.3)$	V
R_{OUT}	Receiver Output Voltage Range	-0.3 to $(V_{CC} + 0.3)$	V
T_{SHORT}	Short Circuit Duration on T_{OUT}	Continuous	
T_{stg}	Storage Temperature Range	-65 to 150	$^{\circ}C$

Absolute Maximum Ratings are those values beyond which damage to the device may occur. Functional operation under these condition is not implied. V+ and V- can have a maximum magnitude of +7V, but their absolute addition can not exceed 13 V.

ESD PERFORMANCE: TRANSMITTER OUTPUTS, RECEIVER INPUTS

Symbol	Parameter	Test Conditions	Min.	Typ.	Max.	Unit
ESD	ESD Protection Voltage	Human Body Model		± 15		KV

ELECTRICAL CHARACTERISTICS ($C_1 - C_4 = 0.1\mu F$, $V_{CC} = 5V \pm 5\%$, $T_A = MIN$ to MAX , unless otherwise specified. Typical values are referred to $T_A = 25^{\circ}C$)

Symbol	Parameter	Test Conditions	Min.	Typ.	Max.	Unit
V_{CC}	Supply Voltage		4.5	5.0	5.5	V
I_{CC}	V_{CC} Power Supply Current	No Load $T_A = 25^{\circ}C$ $V_{CC} = \pm 10\%$		1.5	3	mA

RECEIVER ELECTRICAL CHARACTERISTICS ($C_1 - C_4 = 0.1\mu F$, $V_{CC} = 5V \pm 5\%$, $T_A = MIN$ to MAX , unless otherwise specified. Typical values are referred to $T_A = 25^{\circ}C$)

Symbol	Parameter	Test Conditions	Min.	Typ.	Max.	Unit
V_{RIN}	Receiver Input Voltage Operating Range		-15		15	V
V_{RIL}	Input Threshold Low	$T_A = 25^{\circ}C$ $V_{CC} = 5V$	0.8	1.2		V
V_{RIH}	Input hreshold High	$T_A = 25^{\circ}C$ $V_{CC} = 5V$		1.7	2.8	V
V_{RIHYS}	Input Hysteresys	$V_{CC} = 5V$,	0.2	0.5	1	V
R_{RIN}	Input Resistance	$T_A = 25^{\circ}C$ $V_{IN} = \pm 15V$	3	5	7	$K\Omega$
V_{OL}	Output Voltage Low	$I_{OUT} = 3.2mA$ $V_{CC} = 5V$			0.4	V
V_{OH}	Output Voltage High	$I_{OUT} = -1mA$	3.5			V

TRANSMITTER ELECTRICAL CHARACTERISTICS ($C_1 - C_4 = 0.1\mu\text{F}$, $V_{\text{CC}} = 5\text{V} \pm 5\%$, $T_A = \text{MIN to MAX}$, unless otherwise specified. Typical values are referred to $T_A = 25^\circ\text{C}$)

Symbol	Parameter	Test Conditions	Min.	Typ.	Max.	Unit
V_{TOUT}	Output Voltage Swing	All Driver loaded with $3\text{K}\Omega$ to GND	± 5	± 7		V
R_{OUT}	Transmitter Output Resistance	$V_{\text{CC}} = V_+ = V_- = 0\text{V}$ $V_{\text{OUT}} = \pm 2\text{V}$	300			Ω
I_{SC}	Output Short Circuit Current	Infinite duration $V_{\text{OUT}} = 0\text{V}$		± 18		mA
I_{IL}	Input Pull-Up Current	$T_{\text{IN}} = 0\text{V}$		15	200	μA
V_{TIL}	Input Logic Threshold Low				0.8	V
V_{TIH}	Input Logic Threshold High		0.2			V

TIMING CHARACTERISTICS ($C_1 - C_4 = 0.1\mu\text{F}$, $V_{\text{CC}} = 5\text{V} \pm 5\%$, $T_A = \text{MIN to MAX}$, unless otherwise specified. Typical values are referred to $T_A = 25^\circ\text{C}$)

Symbol	Parameter	Test Conditions	Min.	Typ.	Max.	Unit
D_{R}	Maximum Data Rate	$R_{\text{L}} = 3\text{K}\Omega$ $C_{\text{L}} = 1000\text{pF}$	480			Kbps
t_{PHLR} t_{PLHR}	Receiver Propagation Delay	RS-232 to TTL		250		ns
t_{PHLT} t_{PLHT}	Transmitter Propagation Delay	TTL to RS-232		200	500	ns

APPLICATION CIRCUITS

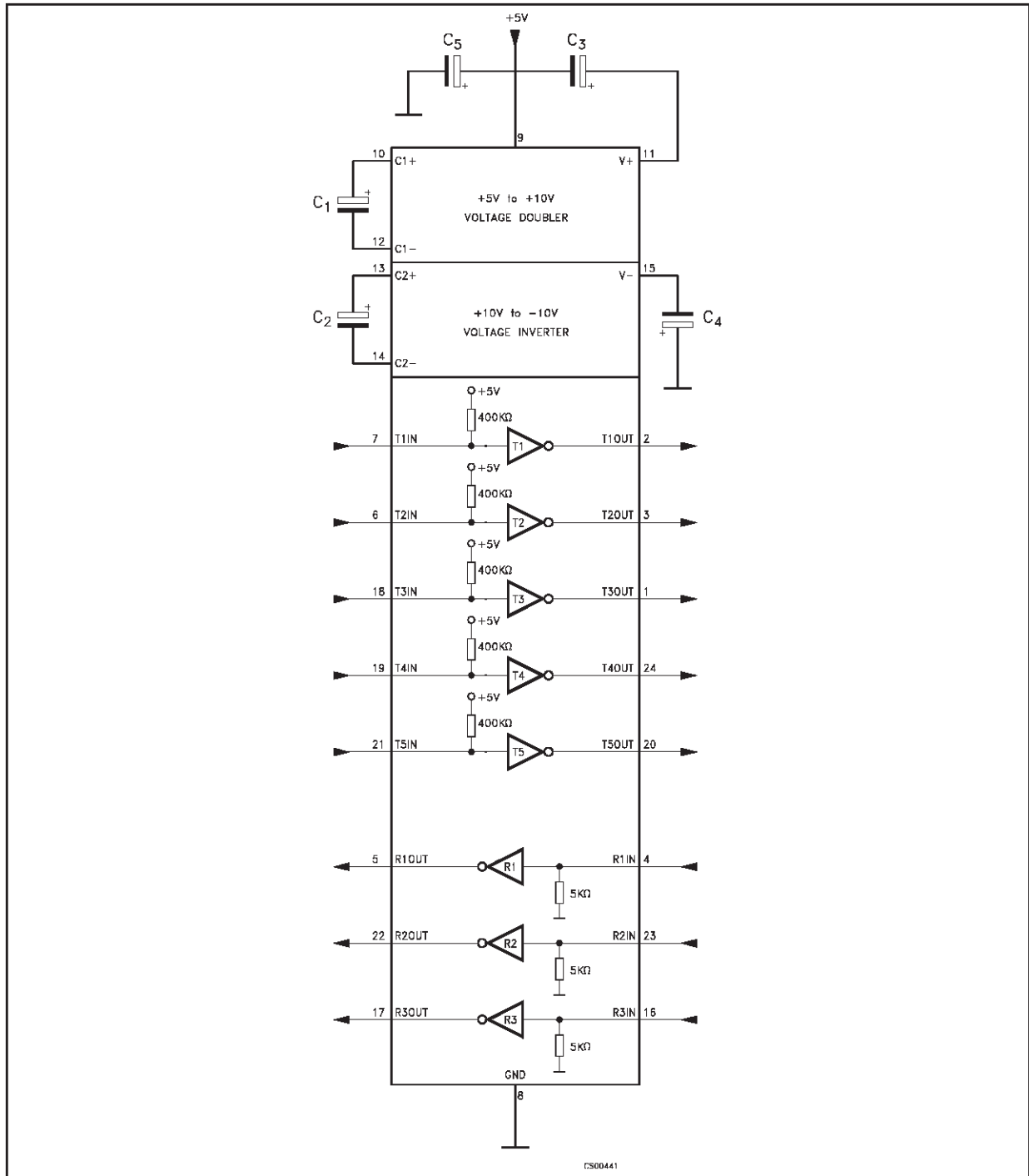

CAPACITANCE VALUE (μF)

C1	C2.	C3	C4	C5
0.1	0.1	0.1	0.1	0.1

SO-24 MECHANICAL DATA

DIM.	mm.			inch		
	MIN.	TYP	MAX.	MIN.	TYP.	MAX.
A			2.65			0.104
a1	0.1		0.2	0.004		0.008
a2			2.45			0.096
b	0.35		0.49	0.014		0.019
b1	0.23		0.32	0.009		0.012
C		0.5			0.020	
c1	45° (typ.)					
D	15.20		15.60	0.598		0.614
E	10.00		10.65	0.393		0.419
e		1.27			0.050	
e3		13.97			0.550	
F	7.40		7.60	0.291		0.300
L	0.50		1.27	0.020		0.050
S	8° (max.)					

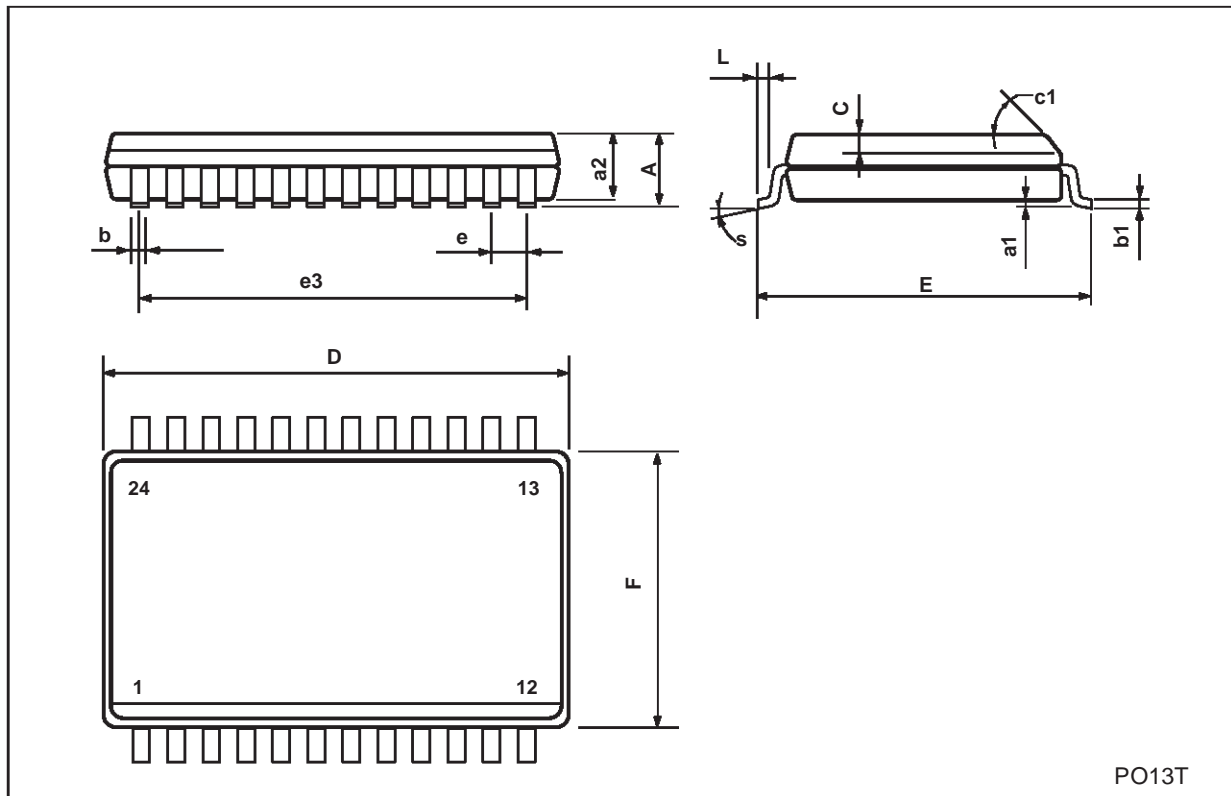

SSOP24 MECHANICAL DATA

DIM.	mm.			inch		
	MIN.	TYP	MAX.	MIN.	TYP.	MAX.
A			2			0.079
A1			0.25			0.010
A2	1.51		2.00	0.059		0.079
b	0.25	0.30	0.35	0.010	0.012	0.014
c	0.10		0.35	0.004		0.014
D	8.35		9.35	0.329		0.368
E	7.6		8.7	0.246	0.252	0.256
E1	5.02	6.10	6.22	0.198	0.240	0.245
e		0.65 BSC			0.0256 BSC	
K	0°		10°	0°		10°
L	0.25	0.50	0.80	0.010	0.020	0.031

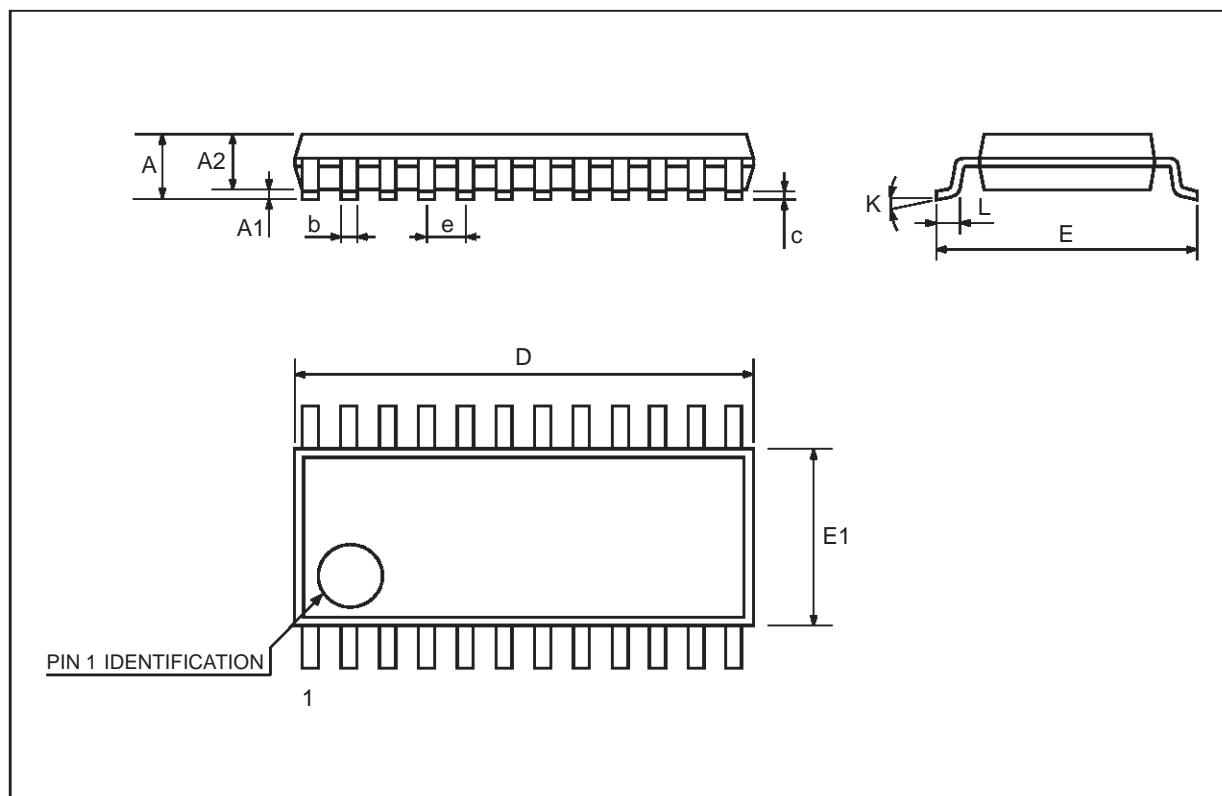

TSSOP24 MECHANICAL DATA

DIM.	mm.			inch		
	MIN.	TYP	MAX.	MIN.	TYP.	MAX.
A			1.1			0.043
A1	0.05		0.15	0.002		0.006
A2		0.9			0.035	
b	0.19		0.30	0.0075		0.0118
c	0.09		0.20	0.0035		0.0079
D	7.7		7.9	0.303		0.311
E	6.25		6.5	0.246		0.256
E1	4.3		4.5	0.169		0.177
e		0.65 BSC			0.0256 BSC	
K	0°		8°	0°		8°
L	0.50		0.70	0.020		0.028

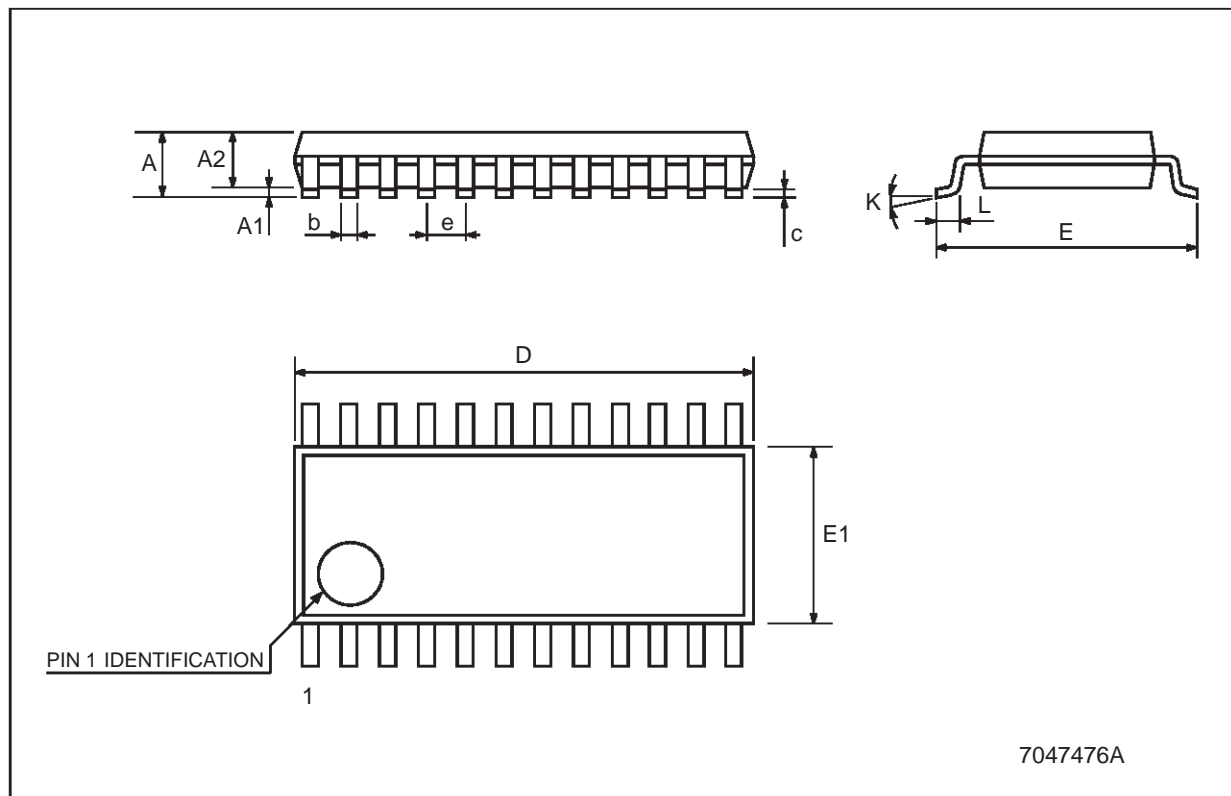

Information furnished is believed to be accurate and reliable. However, STMicroelectronics assumes no responsibility for the consequences of use of such information nor for any infringement of patents or other rights of third parties which may result from its use. No license is granted by implication or otherwise under any patent or patent rights of STMicroelectronics. Specifications mentioned in this publication are subject to change without notice. This publication supersedes and replaces all information previously supplied. STMicroelectronics products are not authorized for use as critical components in life support devices or systems without express written approval of STMicroelectronics.

© The ST logo is a registered trademark of STMicroelectronics

© 2002 STMicroelectronics - Printed in Italy - All Rights Reserved
STMicroelectronics GROUP OF COMPANIES

Australia - Brazil - Canada - China - Finland - France - Germany - Hong Kong - India - Israel - Italy - Japan - Malaysia - Malta - Morocco
Singapore - Spain - Sweden - Switzerland - United Kingdom - United States.

© <http://www.st.com>

