



ST26C32A

CMOS QUAD 3-STATE DIFFERENTIAL LINE RECEIVER

- CMOS DESIGN FOR LOW POWER
- $\pm 0.2V$ SENSIVITY OVER INPUT COMMON MODE VOLTAGE RANGE
- TYPICAL PROPAGATION DELAYS: 19ns
- TYPICAL INPUT HYSTERESIS: 60mV
- INPUT WILL NOT LOAD LINE WHEN $V_{CC}=0V$
- MEETS THE REQUIREMENTS OF EIA STANDARD RS-422, RS-423
- 3-STATE OUTPUTS FOR CONNECTION TO SYSTEM BUSES
- AVAILABLE IN SURFACE MOUNT

DESCRIPTION

The ST26C32A is a quad differential line receiver designed to meet the RS-422, RS-423 standards for balanced and unbalanced digital data transmission, while retaining the low power characteristics of CMOS. The ST26C32A has an input sensitivity of 200mV over the common mode input voltage range of $\pm 7V$. The ST26C32A features internal pull-up and pull-down resistors

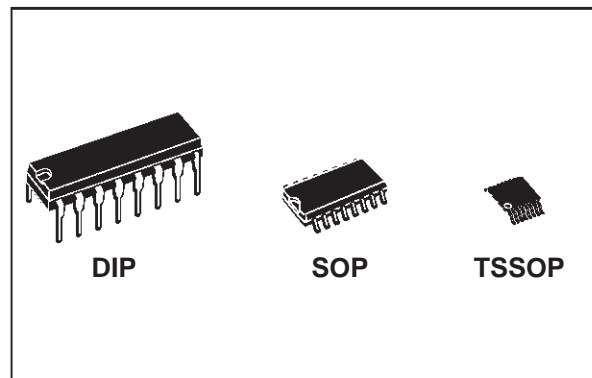

which prevent output oscillation on unused channels. The ST26C32A provides an enable and disable function to all four receivers and features 3-STATE output with 6mA source and sink capability.

ORDER CODES

Type	Temperature Range	Package	Comments
ST26C32ABN	-40 to 85 °C	DIP-16	25 parts per tube / 40 tube per box
ST26C32ABD	-40 to 85 °C	SO-16 (Tube)	50 parts per tube / 20 tube per box
ST26C32ABDR	-40 to 85 °C	SO-16 (Tape & Reel)	2500 parts per reel
ST26C32ABTR	-40 to 85 °C	TSSOP16 (Tape & Reel)	2500 parts per reel

PIN CONFIGURATION

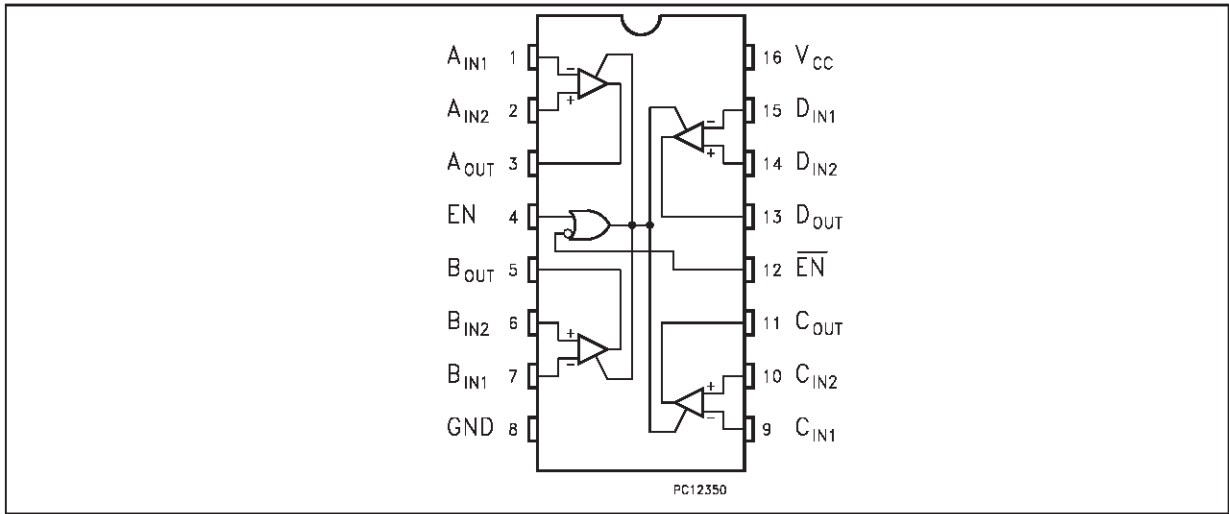

PIN DESCRIPTION

PIN No	SYMBOL	NAME AND FUNCTION
1	A _{IN1}	INPUT A1
2	A _{IN2}	INPUT A2
3	A _{OUT}	Channel A Output
4	EN	ENABLE
5	B _{OUT}	Channel B Output
6	B _{IN2}	INPUT B2
7	B _{IN1}	INPUT B1
8	GND	Ground
9	C _{IN1}	INPUT C1
10	C _{IN2}	INPUT C2
11	C _{OUT}	Channel C Output
12	EN-bar	ENABLE
13	D _{OUT}	Channel D Output
14	D _{IN2}	INPUT D2
15	D _{IN1}	INPUT D1
16	V _{CC}	Supply Voltage

TRUTH TABLE

ENABLE	EN-bar	INPUT	OUTPUT
L	H	X	Z
All other combinations of enable inputs		$V_{ID} \geq V_{TH(MAX)}$	H
		$V_{ID} \leq V_{TH(MIN)}$	L
		Open	H

L=Low Voltage State
H=High Logic State
X=Don't Care
Z=High Impedance

ABSOLUTE MAXIMUM RATINGS (Note 1, 2)

Symbol	Parameter	Value	Unit
V_{CC}	Supply Voltage	7	V
V_{CM}	Input Common Mode Range	± 14	V
V_{DIFF}	Differential Input Voltage	± 14	V
V_{IN}	Enable Input Voltage	7	V
I_{OMAX}	Maximum Current per Output	± 25	mA
T_{stg}	Storage Temperature Range	-65 to +150	$^{\circ}C$

Note 1: Absolute Maximum Ratings are those values beyond which the safety of the device cannot be guaranteed. They are not meant to imply that the device should be operated at these limits. The table of electrical characteristics provide conditions for actual device operation.

Note 2: Unless otherwise specified, all voltage are referenced to ground.

RECOMMENDED OPERATING CONDITIONS

Symbol	Parameter	Value	Unit
V_{CC}	Supply Voltage	4.5 to 5.5	V
T_A	Operating Temperature Range	-40 to +85	$^{\circ}C$
t_r, t_f	Maximum Enable Input Rise or Fall Times	500	ns

ELECTRICAL CHARACTERISTICS ($V_{CC} = 5V \pm 10\%$ unless otherwise specified, See Note 1)

Symbol	Parameter	Test Conditions	Value			Unit
			Min.	Typ.	Max.	
V_{TH}	Minimum Differential Input Voltage	$V_{OUT} = V_{OH}$ or V_{OL} , $-7V < V_{CM} < 7V$	-200	35	200	mV
R_{IN}	Input Resistance	$V_{IN} = -7V, 7V$ Other Input = GND	5	6.8	10	$K\Omega$
I_{IN}	Input Current	$V_{IN} = 10V$ Other Input = GND		1.1	1.5	mA
		$V_{IN} = -10V$ Other Input = GND		-2	-2.5	
V_{OH}	High Level Output Voltage	$V_{DIFF} = 1V$, $I_{OUT} = -6mA$	3.8	4.2		V
V_{OL}	Low Level Output Voltage	$V_{DIFF} = -1V$, $I_{OUT} = +6mA$		0.2	0.3	V
V_{IH}	Minimum Enable High Input Level Voltage		2			V
V_{IL}	Maximum Enable Low Input Level Voltage				0.8	V
I_{OZ}	3-STATE Output Leakage Current	$V_{OUT} = V_{CC}$ or GND $ENABLE = V_{IL}$ $ENABLE = V_{IH}$		± 0.5	± 5.0	μA
I_I	Maximum Enable Input Current	$V_{IN} = V_{CC}$ or GND			± 1.0	μA
I_{CC}	Quiescent Power Supply Current	$V_{CC} = Max$, $V_{(DIFF)} = 1V$		16	23	mA
V_{HYST}	Input Hysteresis	$V_{CM} = 0V$		60		mV

Note 1: Unless otherwise specified, min/max limits apply across the recommended operating temperature range. All typical are given for $V_{CC} = 5V$ and $T_a = 25^{\circ}C$

SWITCHING CHARACTERISTICS ($V_{CC} = 5V \pm 10\%$, See Note 1)

Symbol	Parameter	Test Conditions	Value			Unit
			Min.	Typ.	Max.	
t_{PLH} t_{PHL}	Propagation Delay Input to Output	$C_L = 50pF$ $V_{DIFF} = 2.5V$ $V_{CM} = 0V$		19	30	ns
t_{RISE} t_{FALL}	Output Rise and Fall Times	$C_L = 50pF$ $V_{DIFF} = 2.5V$ $V_{CM} = 0V$		4	9	ns
t_{PZH} t_{PZL}	Propagation Enable Time to Output	$C_L = 50pF$ $V_{DIFF} = 2.5V$ $R_L = 1000\Omega$		13	23	ns
t_{PHZ} t_{PLZ}	Propagation Disable Time to Output	$C_L = 50pF$ $V_{DIFF} = 2.5V$ $R_L = 1000\Omega$		13	22	ns
D_R	Data Rate	$C_L = 50pF$ $V_{DIFF} = 2.5V$ All Outputs Loaded and Switching	10	20		Mbits/s

Note 1: Unless otherwise specified, min/max limits apply across the recommended operating temperature range.
All typical are given for $V_{CC} = 5V$ and $T_a = 25^\circ C$

Plastic DIP-16 (0.25) MECHANICAL DATA

DIM.	mm			inch		
	MIN.	TYP.	MAX.	MIN.	TYP.	MAX.
a1	0.51			0.020		
B	0.77		1.65	0.030		0.065
b		0.5			0.020	
b1		0.25			0.010	
D			20			0.787
E		8.5			0.335	
e		2.54			0.100	
e3		17.78			0.700	
F			7.1			0.280
l			5.1			0.201
L		3.3			0.130	
Z			1.27			0.050

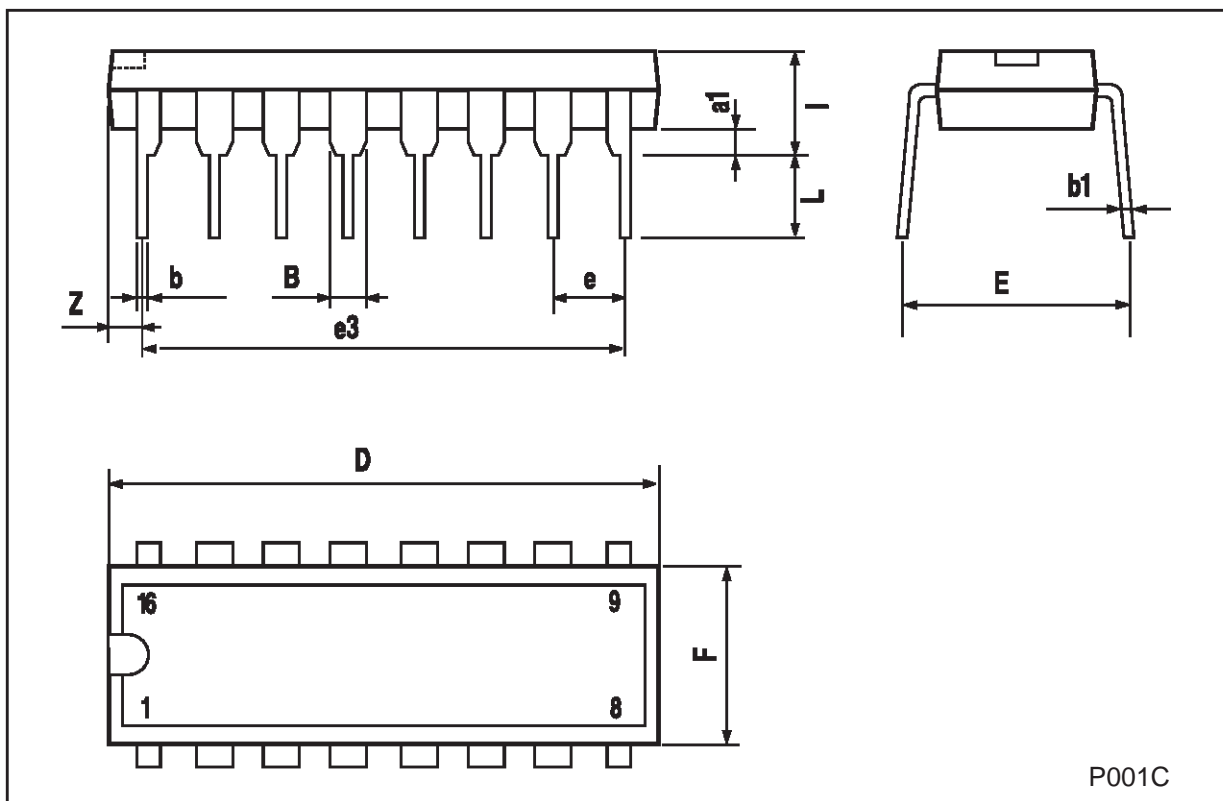

SO-16 MECHANICAL DATA

DIM.	mm			inch		
	MIN.	TYP.	MAX.	MIN.	TYP.	MAX.
A			1.75			0.068
a1	0.1		0.2	0.004		0.007
a2			1.65			0.064
b	0.35		0.46	0.013		0.018
b1	0.19		0.25	0.007		0.010
C		0.5			0.019	
c1	45 (typ.)					
D	9.8		10	0.385		0.393
E	5.8		6.2	0.228		0.244
e		1.27			0.050	
e3		8.89			0.350	
F	3.8		4.0	0.149		0.157
G	4.6		5.3	0.181		0.208
L	0.5		1.27	0.019		0.050
M			0.62			0.024
S	8 (max.)					

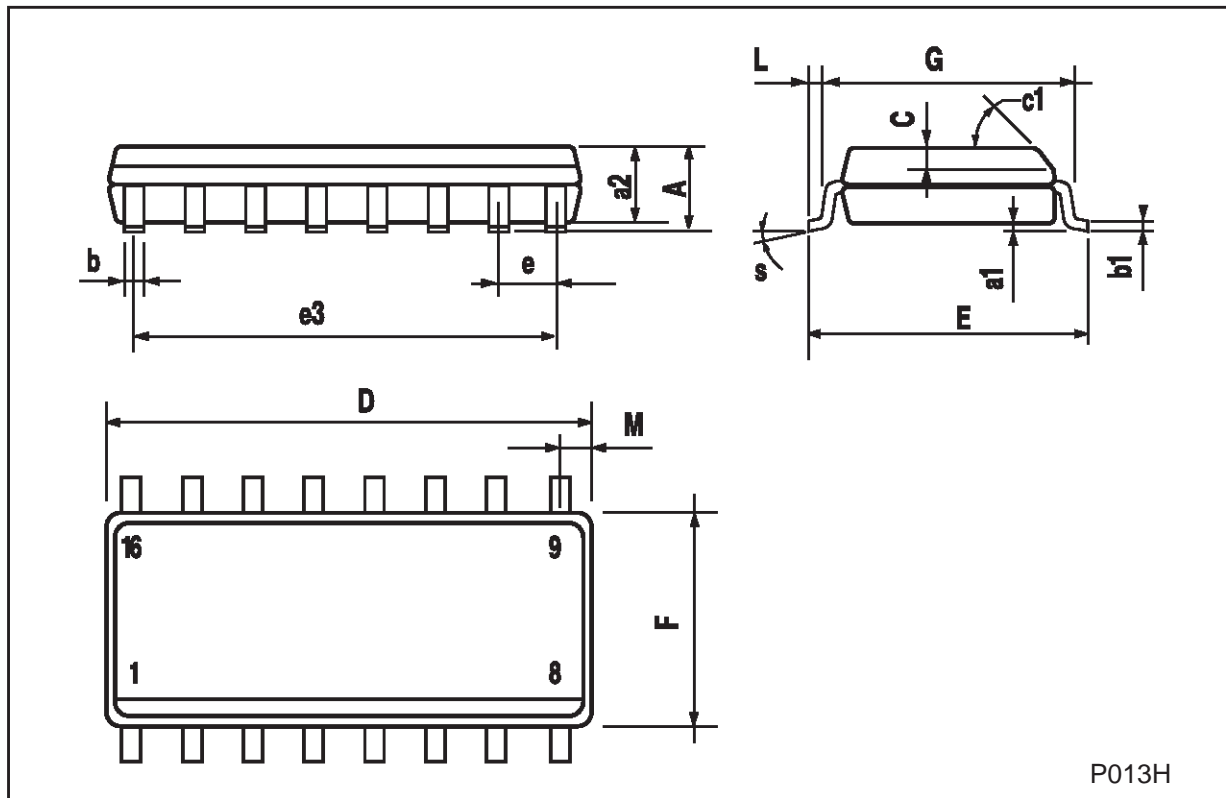

TSSOP16 MECHANICAL DATA

DIM.	mm			inch		
	MIN.	TYP.	MAX.	MIN.	TYP.	MAX.
A			1.1			0.433
A1	0.05	0.10	0.15	0.002	0.004	0.006
A2	0.85	0.9	0.95	0.335	0.354	0.374
b	0.19		0.30	0.0075		0.0118
c	0.09		0.20	0.0035		0.0079
D	4.9	5	5.1	0.193	0.197	0.201
E	6.25	6.4	6.5	0.246	0.252	0.256
E1	4.3	4.4	4.48	0.169	0.173	0.176
e		0.65 BSC			0.0256 BSC	
K	0°	4°	8°	0°	4°	8°
L	0.50	0.60	0.70	0.020	0.024	0.028

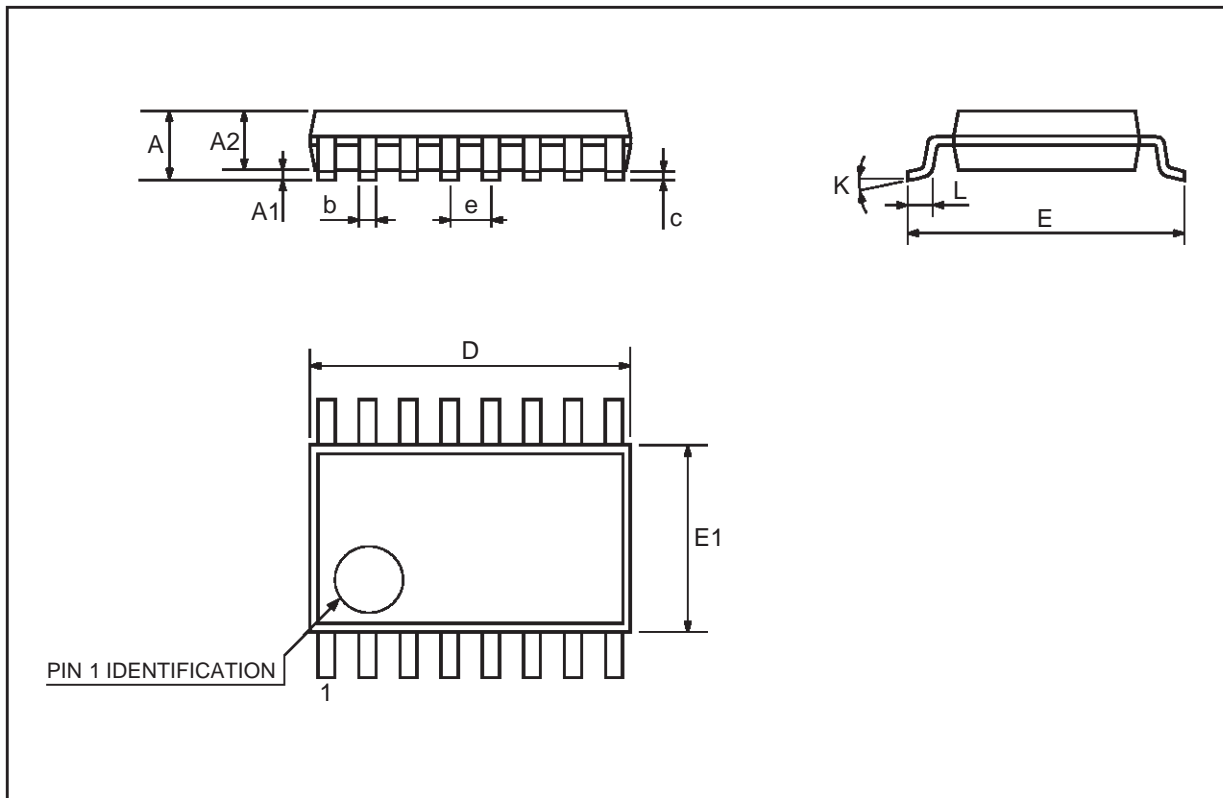

Information furnished is believed to be accurate and reliable. However, STMicroelectronics assumes no responsibility for the consequences of use of such information nor for any infringement of patents or other rights of third parties which may result from its use. No license is granted by implication or otherwise under any patent or patent rights of STMicroelectronics. Specification mentioned in this publication are subject to change without notice. This publication supersedes and replaces all information previously supplied. STMicroelectronics products are not authorized for use as critical components in life support devices or systems without express written approval of STMicroelectronics.

The ST logo is a registered trademark of STMicroelectronics

© 2001 STMicroelectronics – Printed in Italy – All Rights Reserved

STMicroelectronics GROUP OF COMPANIES

Australia - Brazil - China - Finland - France - Germany - Hong Kong - India - Italy - Japan - Malaysia - Malta - Morocco
Singapore - Spain - Sweden - Switzerland - United Kingdom - U.S.A.

<http://www.st.com>