

HIGH VOLTAGE IGNITION COIL DRIVER NPN POWER DARLINGTON

- HIGH VOLTAGE SPECIAL DARLINGTON STRUCTURE
- VERY RUGGED BIPOLAR TECHNOLOGY
- HIGH OPERATING JUNCTION TEMPERATURE
- HIGH DC CURRENT GAIN

APPLICATION

- HIGH RUGGEDNESS ELECTRONIC IGNITION FOR SMALL ENGINES

DESCRIPTION

The ST901T is a high voltage NPN silicon transistor in monolithic special Darlington configuration mounted in Jedec TO-220 plastic package, designed for applications such as electronic ignition for small engines (scooters, lawnmowers, chainsaws).

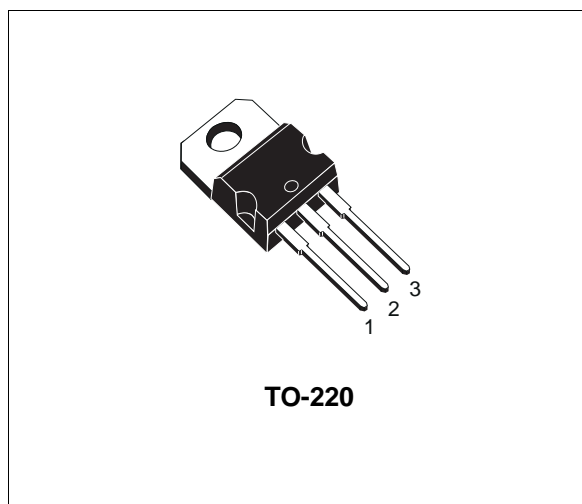

INTERNAL SCHEMATIC DIAGRAM

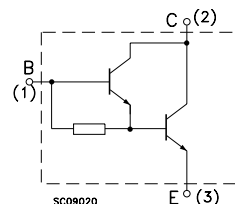

ABSOLUTE MAXIMUM RATINGS

Symbol	Parameter	Value	Unit
V_{CES}	Collector- Emitter Voltage ($V_{BE} = 0$)	500	V
V_{CEO}	Collector-Emitter Voltage ($I_B = 0$)	350	V
V_{EBO}	Emitter-Base Voltage ($I_C = 0$)	5	V
I_C	Collector Current	4	A
I_{CM}	Collector Peak Current	8	A
I_B	Base Current	0.5	A
I_{BM}	Base Peak Current	2.5	A
P_{tot}	Total Dissipation at $T_c \leq 25^\circ\text{C}$	30	W
T_{stg}	Storage Temperature	-65 to 175	$^\circ\text{C}$
T_j	Max. Operating Junction Temperature	175	$^\circ\text{C}$

ST901T

THERMAL DATA

R _{thj-case}	Thermal Resistance Junction-case	Max	5	°C/W
-----------------------	----------------------------------	-----	---	------

ELECTRICAL CHARACTERISTICS (T_{case} = 25 °C unless otherwise specified)

Symbol	Parameter	Test Conditions	Min.	Typ.	Max.	Unit
I _{CEs}	Collector Cut-off Current (I _E = 0)	V _{CE} = 500 V V _{CE} = 500 V T _{case} = 125 °C			100 0.5	μA mA
I _{CEO}	Collector Cut-off Current (I _B = 0)	V _{CE} = 350 V V _{CE} = 350 V T _{case} = 125 °C			100 0.5	μA mA
I _{EBO}	Emitter Cut-off Current (I _C = 0)	V _{EB} = 5 V			10	μA
V _{CEO(sus)*}	Collector-Emitter Sustaining Voltage	I _C = 10 mA L = 10 mH I _B = 0	350			V
V _{CE(sat)*}	Collector-Emitter Saturation Voltage	I _C = 2 A I _B = 20 mA			1.3	V
V _{BE(sat)*}	Base-Emitter Saturation Voltage	I _C = 2 A I _B = 20 mA			1.8	V
h _{FE*}	DC Current Gain	I _C = 2 A V _{CE} = 2 V I _C = 4 A V _{CE} = 2 V	1500 500			
	Functional Test	V _{CC} = 24 V V _{clamp} = 350 V L = 4 mH	4			A
t _s t _f	INDUCTIVE LOAD Storage Time Fall Time	V _{CC} = 12 V V _{clamp} = 250 V L = 4 mH I _C = 2 A I _B = 20 mA V _{BE} = -3 V		15 1.5		μs μs

* Pulsed: Pulse duration = 300 μs, duty cycle 1.5 %

TO-220 MECHANICAL DATA

DIM.	mm			inch		
	MIN.	TYP.	MAX.	MIN.	TYP.	MAX.
A	4.40		4.60	0.173		0.181
C	1.23		1.32	0.048		0.051
D	2.40		2.72	0.094		0.107
D1		1.27			0.050	
E	0.49		0.70	0.019		0.027
F	0.61		0.88	0.024		0.034
F1	1.14		1.70	0.044		0.067
F2	1.14		1.70	0.044		0.067
G	4.95		5.15	0.194		0.203
G1	2.4		2.7	0.094		0.106
H2	10.0		10.40	0.393		0.409
L2		16.4			0.645	
L4	13.0		14.0	0.511		0.551
L5	2.65		2.95	0.104		0.116
L6	15.25		15.75	0.600		0.620
L7	6.2		6.6	0.244		0.260
L9	3.5		3.93	0.137		0.154
DIA.	3.75		3.85	0.147		0.151

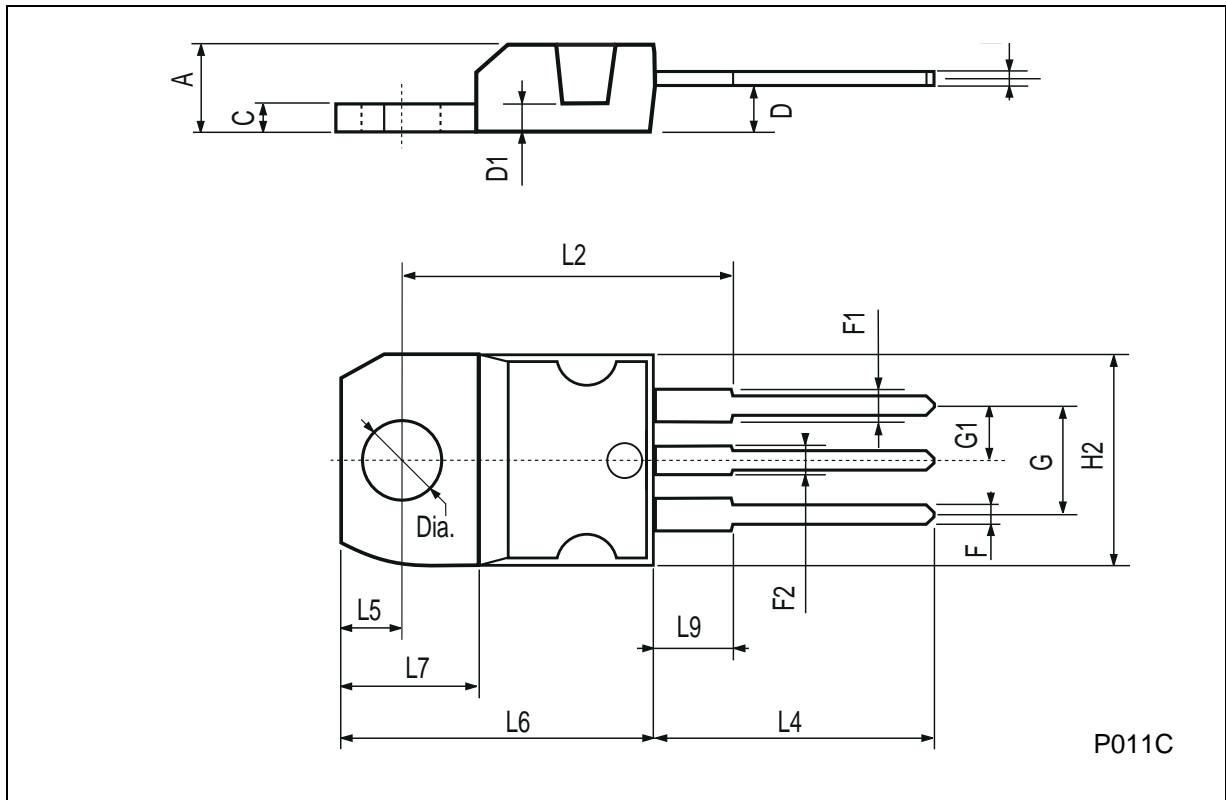

Information furnished is believed to be accurate and reliable. However, SGS-THOMSON Microelectronics assumes no responsibility for the consequences of use of such information nor for any infringement of patents or other rights of third parties which may result from its use. No license is granted by implication or otherwise under any patent or patent rights of SGS-THOMSON Microelectronics. Specifications mentioned in this publication are subject to change without notice. This publication supersedes and replaces all information previously supplied. SGS-THOMSON Microelectronics products are not authorized for use as critical components in life support devices or systems without express written approval of SGS-THOMSON Microelectronics.

© 1997 SGS-THOMSON Microelectronics - Printed in Italy - All Rights Reserved

SGS-THOMSON Microelectronics GROUP OF COMPANIES
Australia - Brazil - Canada - China - France - Germany - Hong Kong - Italy - Japan - Korea - Malaysia - Malta - Morocco - The Netherlands -
Singapore - Spain - Sweden - Switzerland - Taiwan - Thailand - United Kingdom - U.S.A
...