



# STB7002

## 1.8GHz THREE GAIN LEVEL LNA

- FULLY INTEGRATED 1.8GHz LNA
- THREE GAIN LEVELS (0dB, 18dB, 26dB typ. @ 2.8V)
- LOW NOISE FIGURE
- TEMPERATURE COMPENSATED

### APPLICATIONS

- DCS HANDSETS

### DESCRIPTION

The STB7002 is a Silicon monolithic amplifier, that offers low noise figure and three gain levels for 1.8GHz applications. STB7002 is housed in a small industry-standard MSOP8-EP surface mount package, requiring very little board space (50% reduction vs SO8 Package). MSOP8-EP dimensions are 3mmx5mm with a 1.1mm thickness. STB7002 is ESD protected and requires minimum external components in the application circuit, for the on-chip bias and gain control. Furthermore, temperature and supply voltage compensation ensures high stability over a wide range of operating conditions.

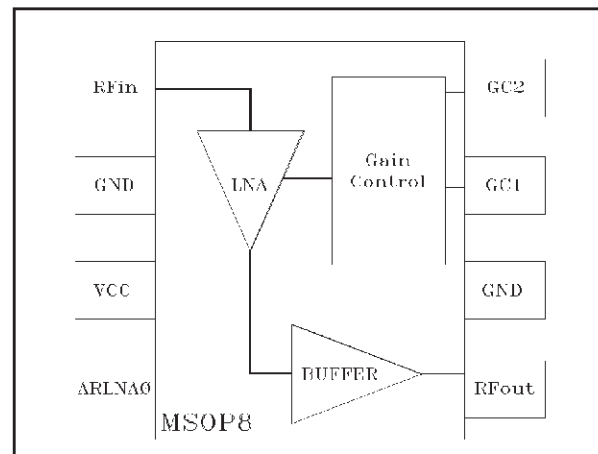
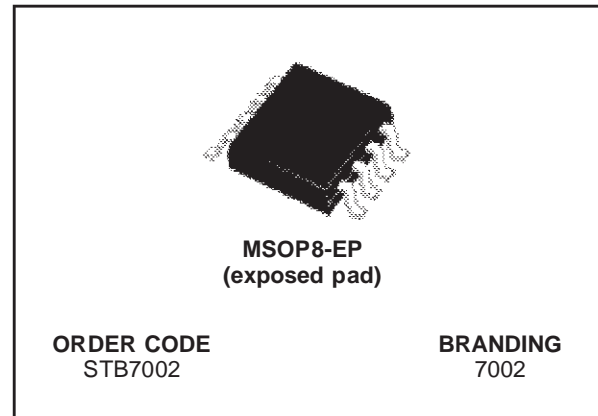

### ABSOLUTE MAXIMUM RATINGS

Symbol	Parameter	Value	Unit
V <sub>cc</sub>	Supply voltage	4	V
T <sub>j</sub>	Junction Temperature	150	°C
T <sub>stg</sub>	Storage temperature	-40 to +85	°C

### THERMAL DATA

Symbol	Parameter	Value	Unit
R <sub>th(j-a)</sub>	Junction -ambient Thermal Resistance	TBD	°C/W

## STB7002

### ELECTRICAL SPECIFICATION ( $T_{amb} = 25^{\circ}\text{C}$ , $V_{cc} = 2.8\text{V}$ )

Symbol	Parameters	Test Conditions	Min.	Typ.	Max.	Unit
$V_{cc}$	Supply voltage		2.7	2.8	2.9	V
$I_{bias}$	Bias current	for $G_{p1}^{(1)}$ $G_{p2}^{(1)}$ $G_{p3}^{(1)}$	8 14 10	11.5 17.5 15.0	15.0 22.5 19	mA
$I_{stby}$	Standby current				20	$\mu\text{A}$
f	Frequency range		1805		1880	MHz
$G_{p1,2,3}$	Power gain	$G_{p1}$ $G_{p2}$ $G_{p3}$	-3.0 16.0 24.0	0.0 18.0 26.0	3.0 20.0 28.0	dB
$NF_{1,2,3}$	Noise figure	for $G_{p1}$ $G_{p2}$ $G_{p3}$		9 2.9 2.6		dB
$P1dB_{1,2,3}$	Input 1 dB Compr.Power	for $G_{p1}$ $G_{p2}$ $G_{p3}$		-15.5 -19 -27		dBm
$IIP3_{1,2,3}$	Input Third Order Intercept	for $G_{p1}$ $G_{p2}$ $G_{p3}$		-4 -9 -17		dBm
VSWRi	Input VSWR	for $G_{p1}$ $G_{p2}$ $G_{p3}$			2.5:1 2.2:1 1.5:1	
VSWRo	Output VSWR	for $G_{p1}$ $G_{p2}$ $G_{p3}$			1.3:1 1.5:1 1.8:1	
AZout	Zout LNA on/off				15	%

Note(1) : Gp1 min gain, Gp2 mid gain and Gp3 max gain.

### PINOUT

Pin Number	Symbol	Description	Evaluation circuit components
1	RFin	RF input	$L2 = 3.3\text{nH}$ , $C2 = 0.5\text{pF}$
2	Gnd	Ground	
3	Vcc	Voltage supply	$C4 = 4\text{pF}$ , $L1 = 110\text{nH}$ , $C7 = 10\text{nF}$
4	ARLNA0	Enable for power down	$C3 = 10\text{nF}$
5	RFout	RF output	$C9 = 3\text{pf}$ , $L3 = 5.6\text{nH}$ , $C10 = 10\text{nF}$ , $C11 = 100\text{pF}$ , $L4 = 110\text{nH}$
6	Gnd	Ground	
7	GC1	Gain selection	$C5 = 10\text{nF}$
8	GC2	Gain selection	$C8 = 10\text{nF}$

### GAIN SELECTION

	$G_{p1}$	$G_{p2}$	$G_{p3}$
GC1	0	0	1
GC2	0	1	1

TEST CIRCUIT SCHEMATIC

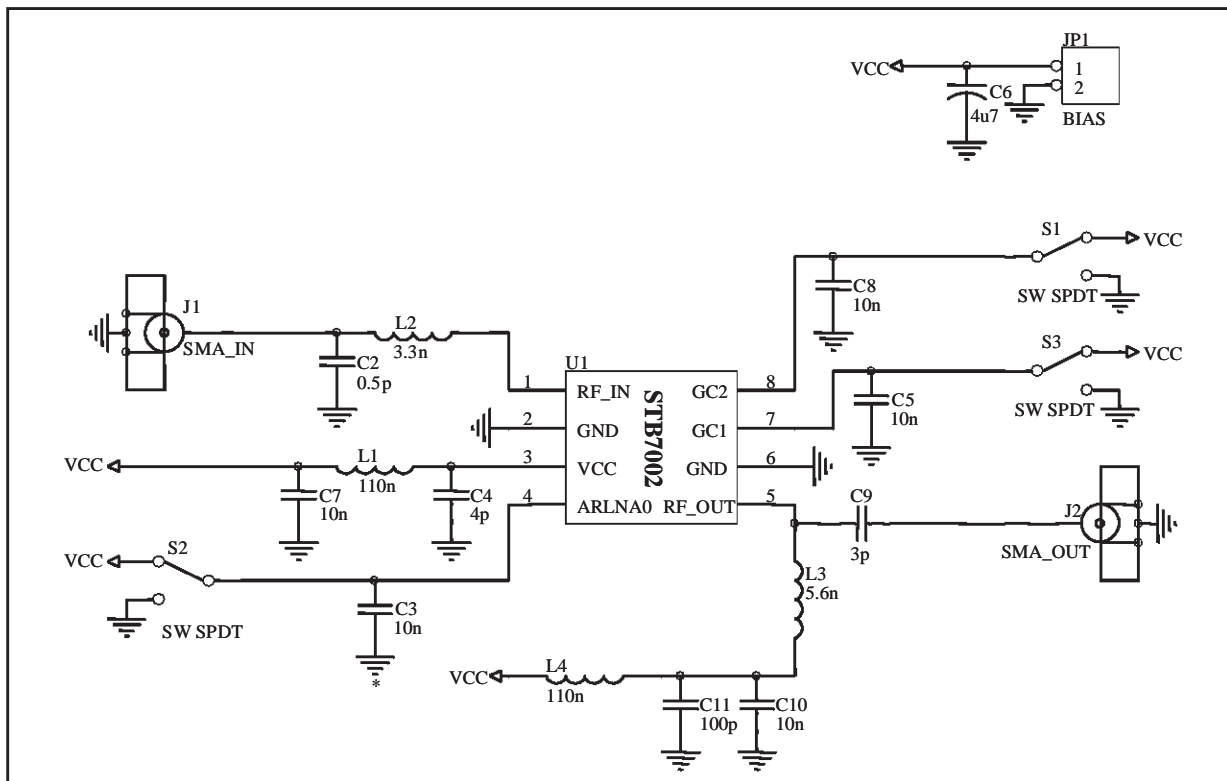

TEST CIRCUIT PHOTOMASTER (board dimensions 23.5x20.3mm)

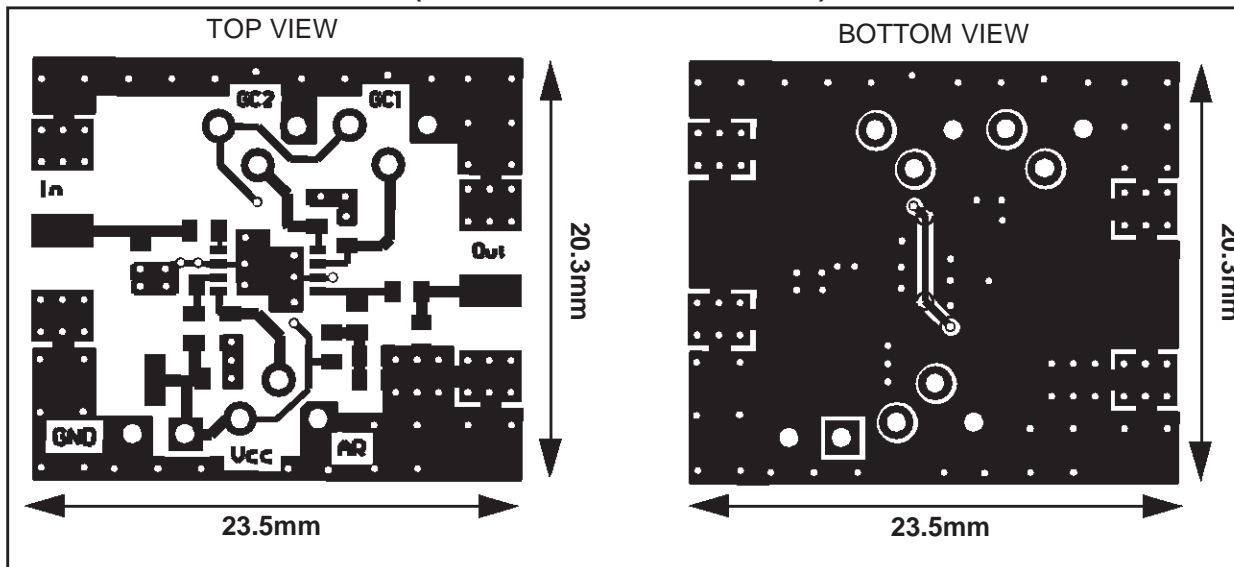

## STB7002

---

### INPUT/OUTPUT VSWR, ISOLATION AND GAIN PARAMETERS (MEASURED DATA)

#### MAX GAIN

Freq.	VSWR <sub>i</sub>	VSWR <sub>o</sub>	Isolation	Gain
1802	1.48	1.94	-36.91	24.83
1813	1.45	1.94	-36.37	24.79
1824	1.43	1.94	-35.51	24.76
1835	1.41	1.93	-35.14	24.75
1846	1.38	1.92	-34.95	24.74
1857	1.36	1.91	-34.03	24.71
1868	1.35	1.89	-34.17	24.68
1879	1.33	1.87	-33.08	24.59
1890	1.32	1.84	-33.53	24.52
1901	1.30	1.83	-32.87	24.45
1912	1.29	1.79	-33.03	24.38
1923	1.28	1.77	-32.55	24.29

#### MID GAIN

Freq.	VSWR <sub>i</sub>	VSWR <sub>o</sub>	Isolation	Gain
1802	2.14	1.67	-36.70	18.32
1813	2.15	1.68	-36.07	18.33
1824	2.14	1.69	-35.58	18.34
1835	2.14	1.69	-35.13	18.37
1846	2.13	1.69	-34.51	18.40
1857	2.12	1.69	-33.92	18.43
1868	2.11	1.68	-33.38	18.45
1879	2.10	1.68	-32.30	18.42
1890	2.10	1.67	-33.39	18.41
1901	2.09	1.66	-32.80	18.39
1912	2.08	1.65	-32.72	18.35
1923	2.08	1.63	-32.20	18.32

**MIN GAIN**

<b>Freq.</b>	<b>VSWRi</b>	<b>VSWRo</b>	<b>Isolation</b>	<b>Gain</b>
1802	2.26	1.21	-34.63	1.97
1813	2.30	1.21	-34.45	1.93
1824	2.33	1.21	-33.83	1.89
1835	2.36	1.21	-33.57	1.86
1846	2.38	1.22	-32.99	1.82
1857	2.41	1.22	-32.3	1.79
1868	2.43	1.22	-31.94	1.76
1879	2.46	1.22	-31.55	1.70
1890	2.48	1.22	-31.91	1.66
1901	2.50	1.22	-31.52	1.63
1912	2.52	1.22	-31.34	1.58
1923	2.53	1.22	-31.09	1.53

# STB7002

## MSOP8-EP MECHANICAL DATA

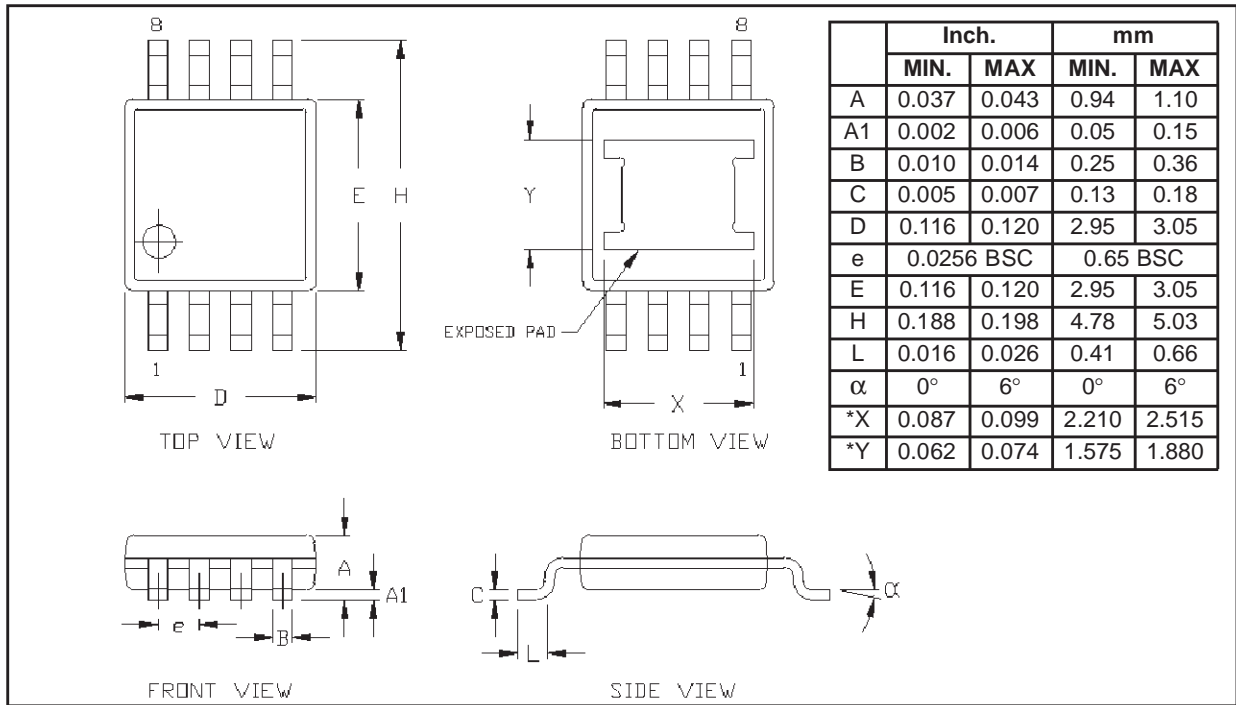

Information furnished is believed to be accurate and reliable. However, STMicroelectronics assumes no responsibility for the consequences of use of such information nor for any infringement of patents or other rights of third parties which may result from its use. No license is granted by implication or otherwise under any patent or patent rights of STMicroelectronics. Specifications mentioned in this publication are subject to change without notice. This publication supersedes and replaces all information previously supplied. STMicroelectronics products are not authorized for use as critical components in life support devices or systems without express written approval of STMicroelectronics.

The ST logo is registered trademark of STMicroelectronics  
© 2002 STMicroelectronics - All Rights Reserved

All other names are the property of their respective owners.

STMicroelectronics GROUP OF COMPANIES  
Australia - Brazil - Canada - China - Finland - France - Germany - Hong Kong - India - Israel - Italy - Japan -  
Malaysia - Malta - Morocco - Singapore - Spain - Sweden - Switzerland - United Kingdom - U.S.A.

<http://www.st.com>