



STB7102

0.5/2.5 GHz UHF LO BUFFER AMPLIFIER

- OPERATING FREQUENCY 500-2500MHz
- LOW CURRENT CONSUMPTION
- EXCELLENT ISOLATION
- ULTRA MINIATURE SOT323-6L PACKAGE

APPLICATIONS

- BUFFER AMPLIFIER FOR 0.5/2.5 GHz APPLICATIONS
- CDMA/PCS LO BUFFER AMPLIFIER

DESCRIPTION

The STB7102, designed for RF Mobile Phone applications (0.5/2.5GHz), is an high isolation Local Oscillator Buffer Amplifier. Manufactured in the third generation of ST proprietary bipolar process, it offers an excellent isolation and a good linearity using only 4mA current consumption. The STB7102 is housed in an ultra miniature package SOT323-6L surface mount package.

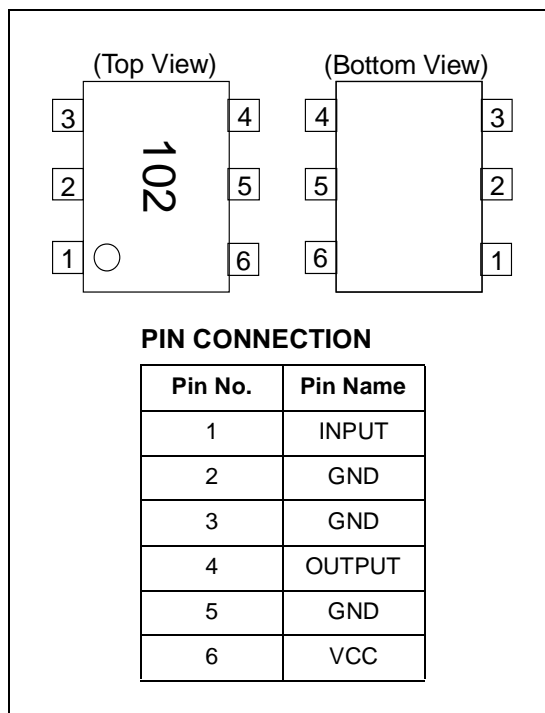
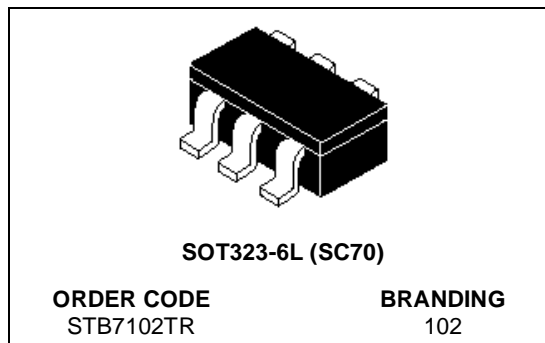

ABSOLUTE MAXIMUM RATINGS

Symbol	Parameter	Conditions	Value	Unit
V _{cc}	Supply voltage		3.3	V
T _{stg}	Storage temperature		-40 to +100	°C
T _a	Operating ambient temperature		-30 to +85	°C

ELECTRICAL CHARACTERISTICS (CELL BAND)

($T_a = +25^\circ\text{C}$, $V_{cc} = 2.7\text{V}$, $Z_s = Z_L = 50\Omega$, tested in circuit shown in fig.1, unless otherwise specified)

Symbol	Parameters	Test Conditions	Min	Typ	Max	Unit
Freq.	Frequency Range		990		1030	MHz
Vcc	Supply Voltage		2.6	2.7	2.8	V
Icc	Current Consumption		3.3	4.3	5.3	mA
P1dB	Output Power at 1dB Compression Point	F = 1010 MHz		-2		dBm
Gp	Power Gain	F = 1010 MHz		16.7		dB
NF	Noise Figure	F = 1010 MHz		2.7		dB
Isol.	Reverse Isolation	F = 1010 MHz		45		dB
RLin	Input Return Loss	F = 1010 MHz		30		dB
RLout	Output Return Loss	F = 1010 MHz		17.8		dB

Figure 1 Cell Band Application Circuit Configuration

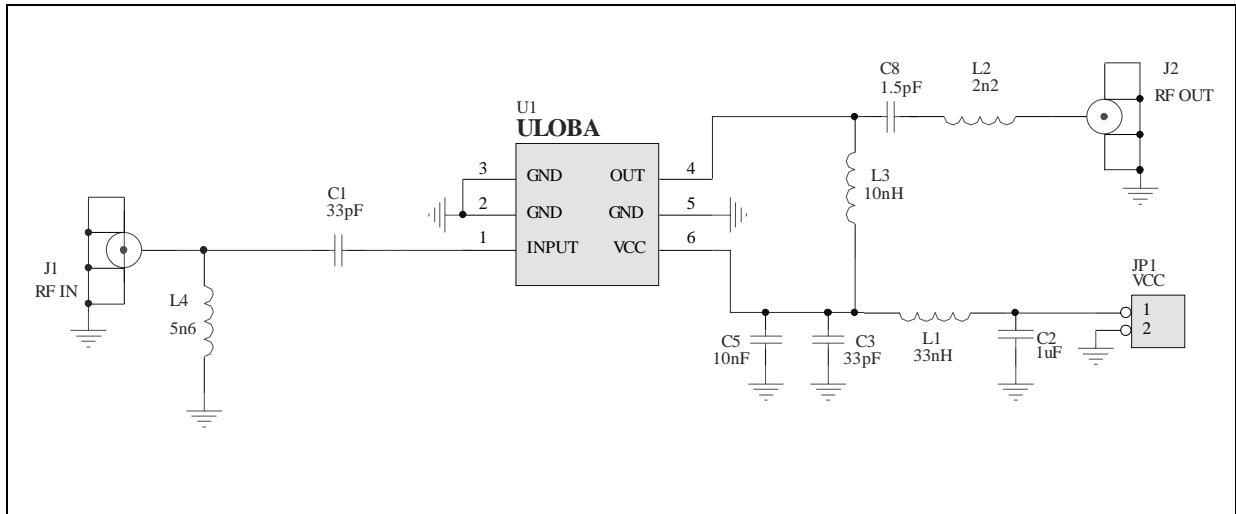

TYPICAL PERFORMANCE (CELL BAND)

Power Gain vs. Frequency and Voltage

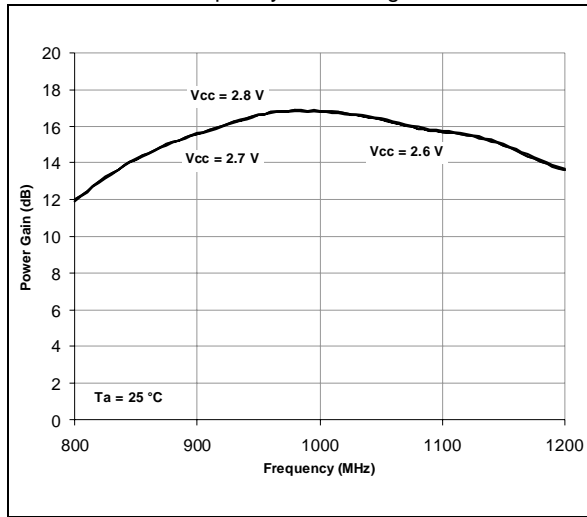

Power Gain vs. Frequency and Temperature

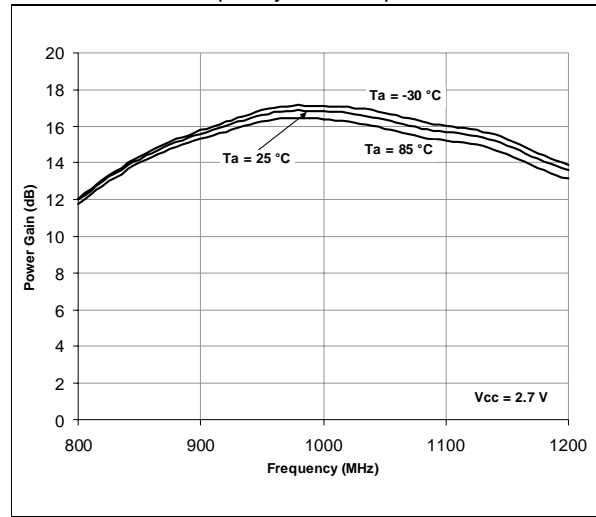

Reverse Isolation vs. Frequency and Voltage

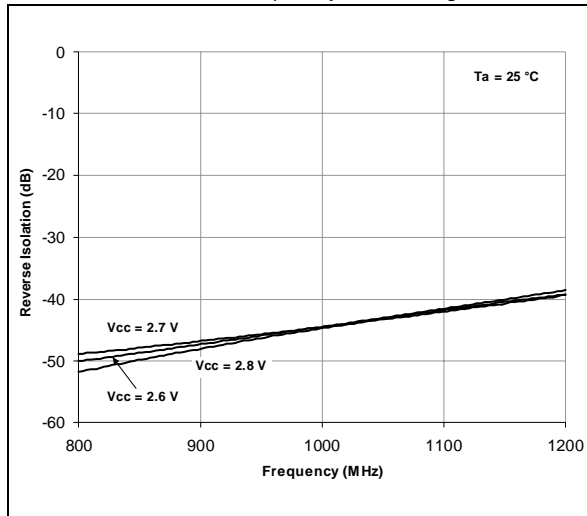

Reverse Isolation vs. Frequency and Temperature

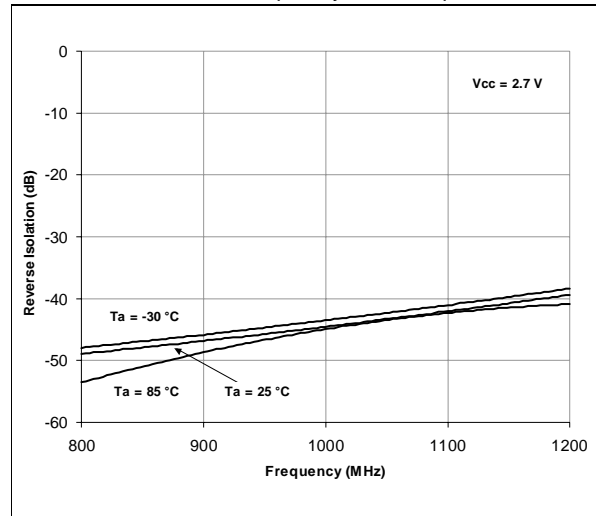

Input Return Loss vs. Frequency and Voltage

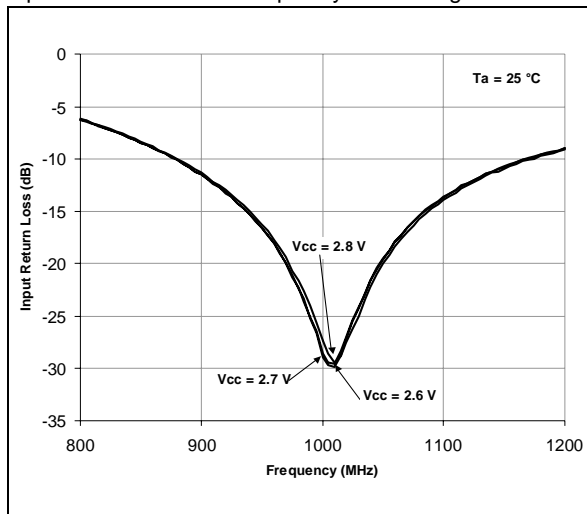

Input Return Loss vs. Frequency and Temperature

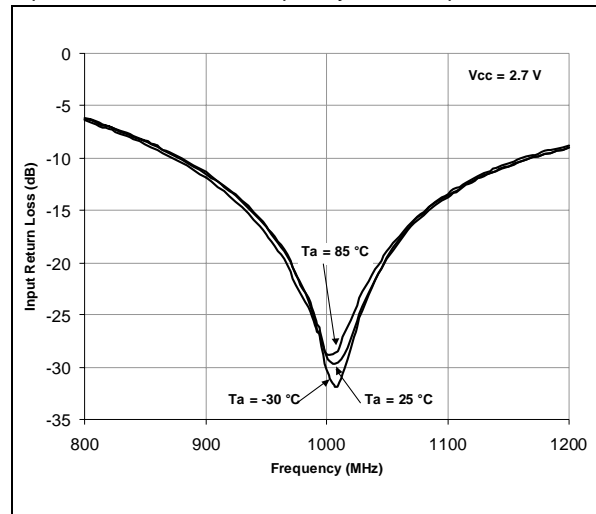

STB7102

TYPICAL PERFORMANCE (CELL BAND)

Output Return Loss vs. Frequency and Voltage

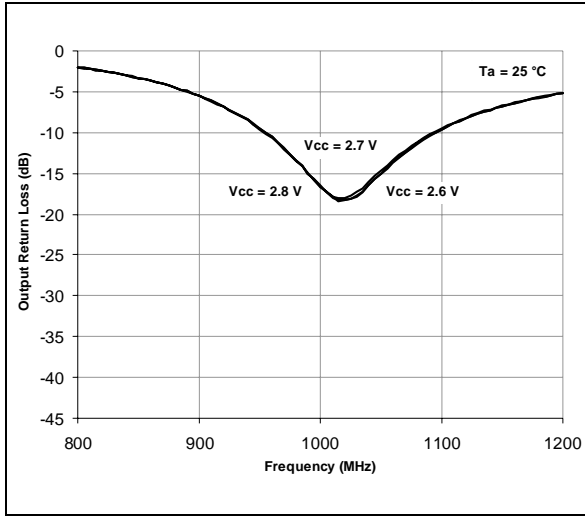

Output Return Loss vs. Frequency and Temperature

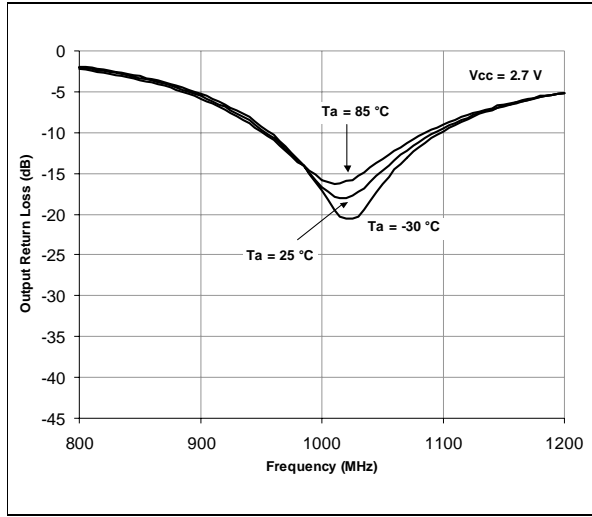

Noise Figure vs. Frequency

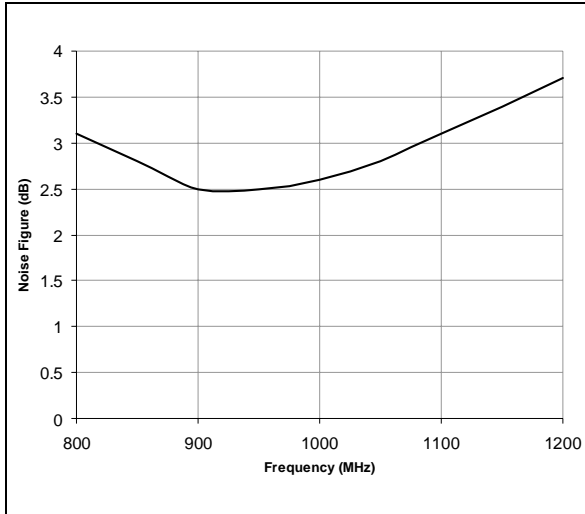

Output Power @ 1dB compression point

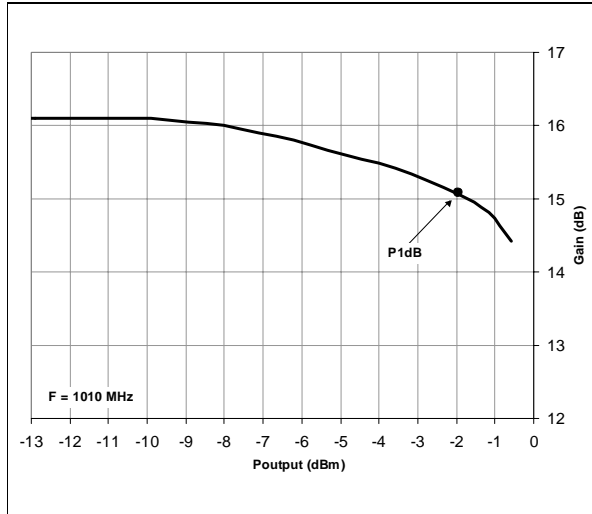

ELECTRICAL CHARACTERISTICS (PCS BAND)

($T_a = +25^\circ\text{C}$, $V_{cc} = 2.7\text{V}$, $Z_s = Z_L = 50\Omega$, tested in circuit shown in fig.2, unless otherwise specified)

Symbol	Parameters	Test Conditions	Min	Typ	Max	Unit
Freq.	Frequency Range		2040		2135	MHz
Vcc	Supply Voltage		2.6	2.7	2.8	V
Icc	Current Consumption		3.3	4.3	5.3	mA
P1dB	Output Power at 1dB Compression Point	F = 2085 MHz		-1		dBm
Gp	Power Gain	F = 2085 MHz		10		dB
NF	Noise Figure	F = 2085 MHz		5		dB
Isol.	Reverse Isolation	F = 2085 MHz		41		dB
RLin	Input Return Loss	F = 2085 MHz		17		dB
RLout	Output Return Loss	F = 2085 MHz		24		dB

Figure 2 PCS Band Application Circuit Configuration

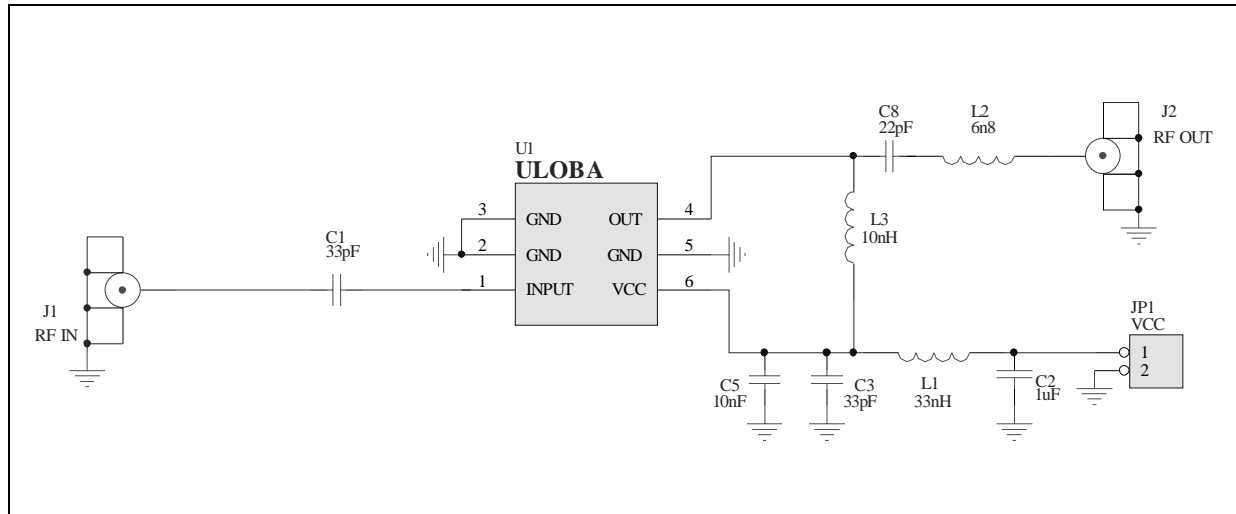

STB7102

TYPICAL PERFORMANCE (PCS BAND)

Power Gain vs. Frequency and Voltage

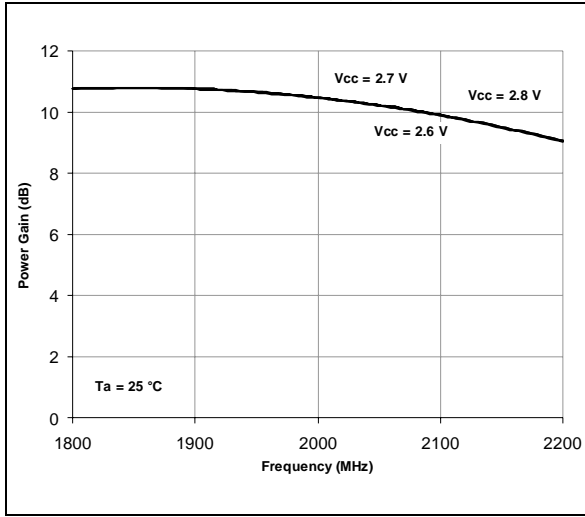

Power Gain vs. Frequency and Temperature

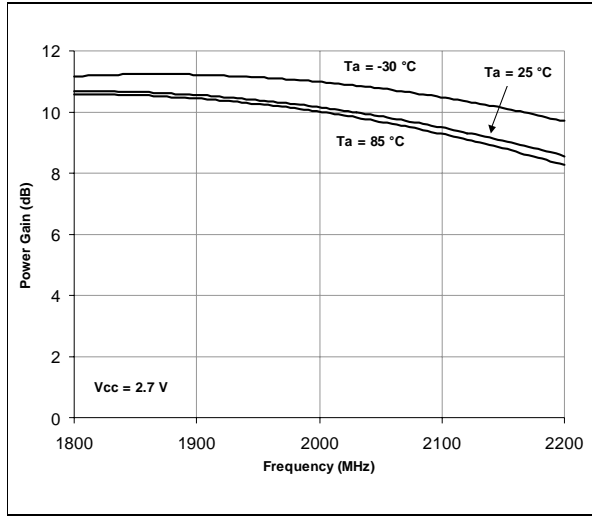

Reverse Isolation vs. Frequency and Voltage

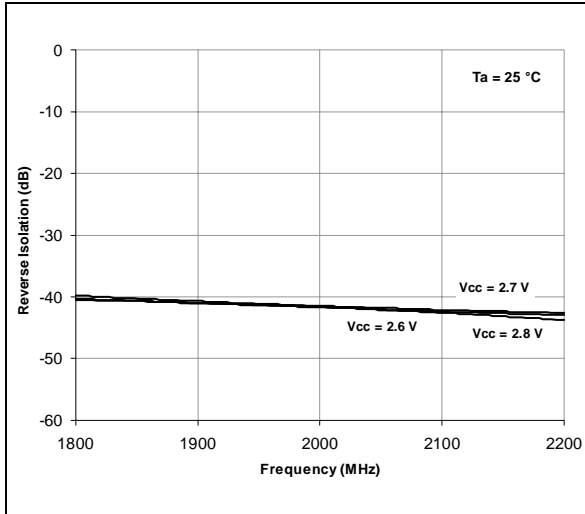

Reverse Isolation vs. Frequency and Temperature

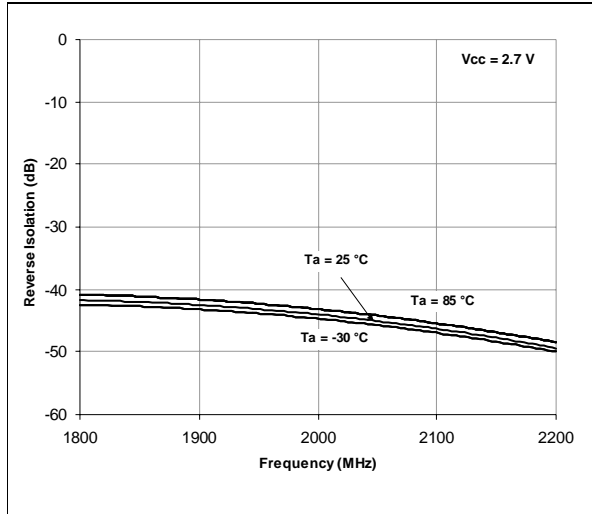

Input Return Loss vs. Frequency and Voltage

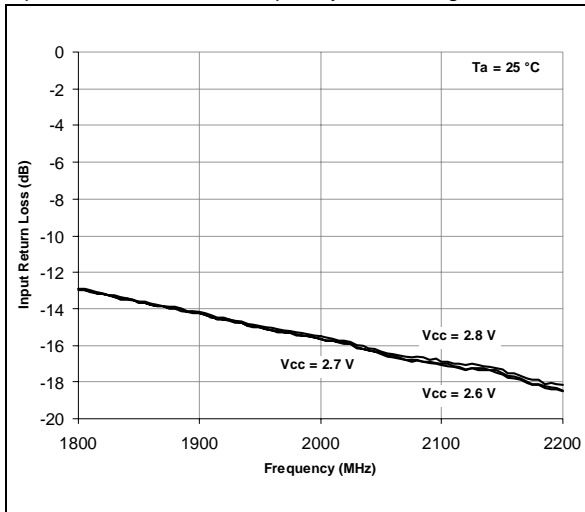

Input Return Loss vs. Frequency and Temperature

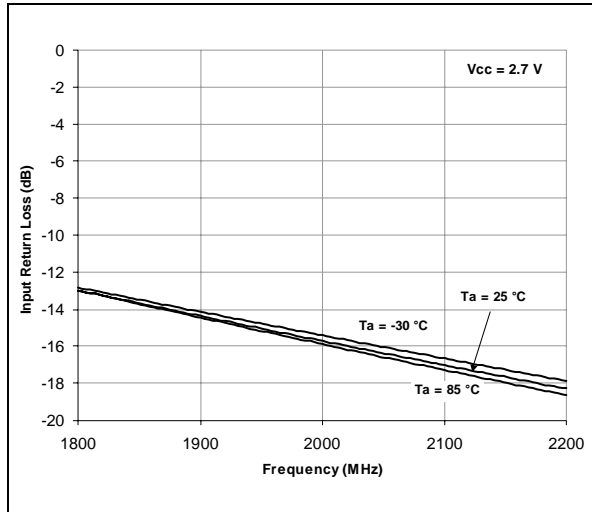

TYPICAL PERFORMANCE (PCS BAND)

Output Return Loss vs. Frequency and Voltage

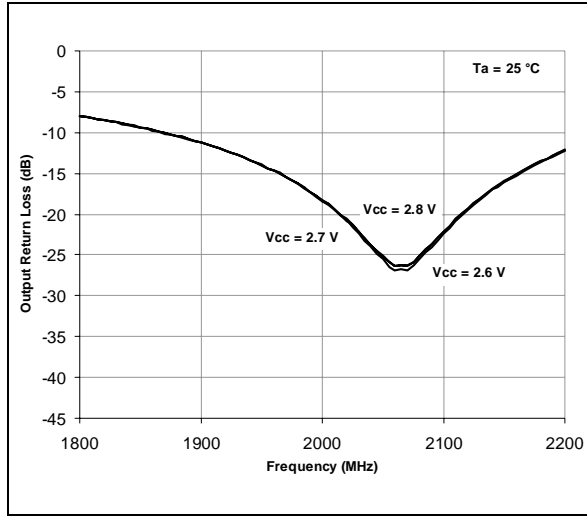

Output Return Loss vs. Frequency and Temperature

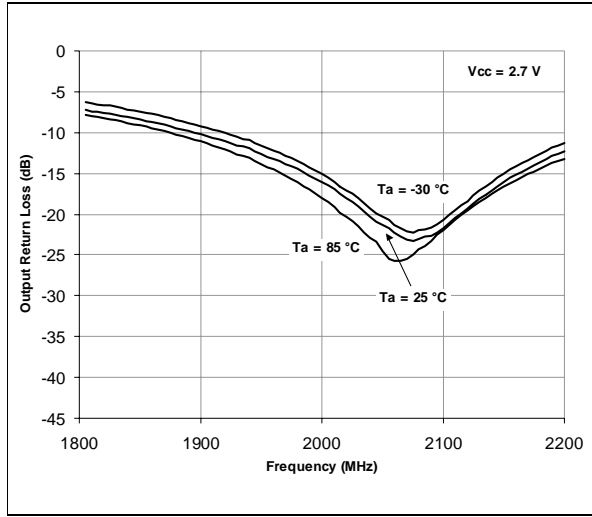

Noise Figure vs. Frequency

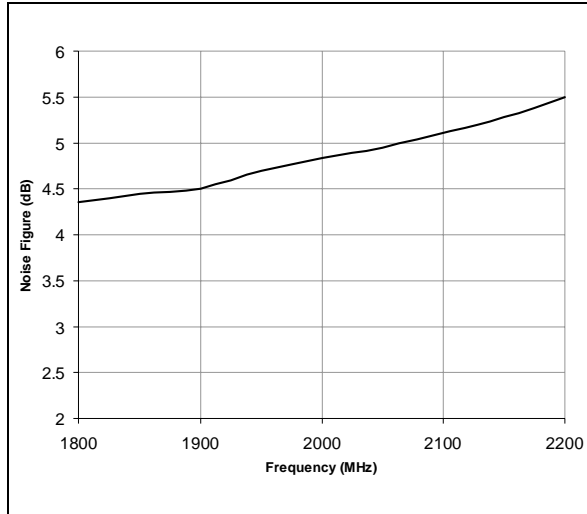

Output Power @ 1dB compression point

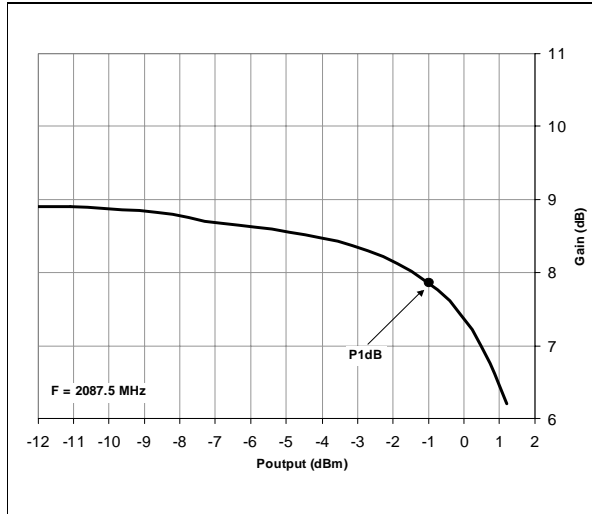

SOT323-6L MECHANICAL DATA

DIM.	mm			Inch		
	MIN.	TYP.	MAX	MIN.	TYP.	MAX
A	0.8		1.1	0.031		0.043
A1	0		0.1	0		0.004
A2	0.8		1	0.0031		0.039
b	0.15		0.3	0.006		0.012
c	0.1		0.18	0.004		0.007
D	1.8		2.2	0.071		0.088
E	1.15		1.35	0.045		0.59
e		0.65			0.025	
H	1.8		2.4	0.071		0.094
Q	0.1		0.4	0.004		0.016

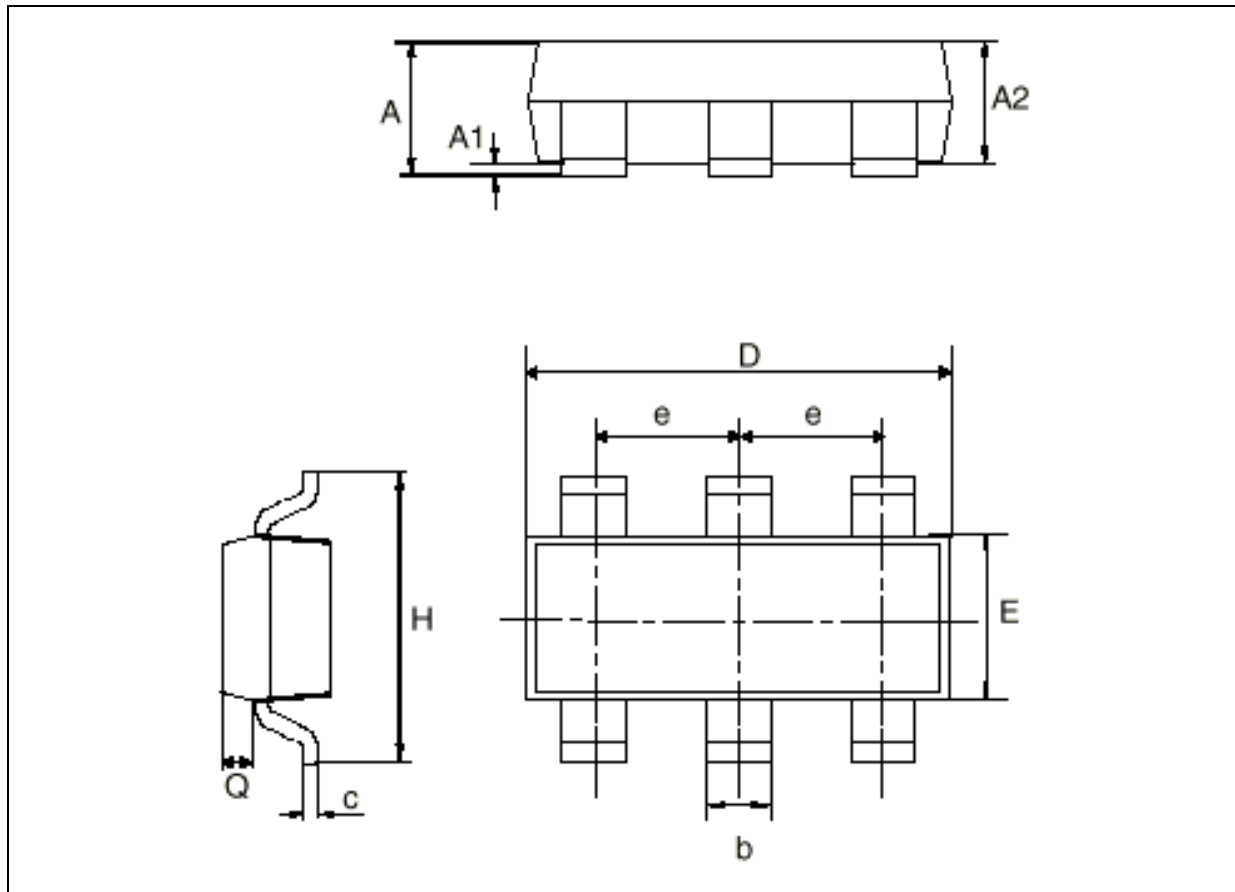

Information furnished is believed to be accurate and reliable. However, STMicroelectronics assumes no responsibility for the consequences of use of such information nor for any infringement of patents or other rights of third parties which may result from its use. No license is granted by implication or otherwise under any patent or patent rights of STMicroelectronics. Specifications mentioned in this publication are subject to change without notice. This publication supersedes and replaces all information previously supplied. STMicroelectronics products are not authorized for use as critical components in life support devices or systems without express written approval of STMicroelectronics.

The ST logo is registered trademark of STMicroelectronics
© 2002 STMicroelectronics - All Rights Reserved

All other names are the property of their respective owners.

STMicroelectronics GROUP OF COMPANIES
Australia - Brazil - Canada - China - Finland - France - Germany - Hong Kong - India - Israel - Italy - Japan -
Malaysia - Malta - Morocco - Singapore - Spain - Sweden - Switzerland - United Kingdom - U.S.A.
<http://www.st.com>