

## LOW VOLTAGE 4Ω SPDT SWITCH

- HIGH SPEED:  
 $t_{PD} = 0.3ns$  (TYP.) at  $V_{CC} = 5V$   
 $t_{PD} = 0.4ns$  (TYP.) at  $V_{CC} = 3.3V$
- LOW POWER DISSIPATION:  
 $I_{CC} = 1\mu A$  (MAX.) at  $T_A = 25^\circ C$
- LOW "ON" RESISTANCE:  
 $R_{ON} = 4\Omega$  (MAX.  $T_A = 25^\circ C$ ) AT  $V_{CC} = 5V$   
 $R_{ON} = 6\Omega$  (TYP.) AT  $V_{CC} = 3V$
- WIDE OPERATING VOLTAGE RANGE:  
 $V_{CC}$  (OPR) = 1.8V TO 5.5V SINGLE SUPPLY

### DESCRIPTION

The STG719 is an high-speed spdt CMOS SWITCH fabricated in silicon gate C<sup>2</sup>MOS technology. It designed to operate from 1.8V to 5.5V, making this device ideal fro prtable applications. It offers 4Ω ON-Resistance Max at 5V 25°C. Additional key faetures are fast switching speed ( $t_{ON} = 7ns$ ,  $t_{OFF} = 4.5ns$ ) and Low



### ORDER CODES

PACKAGE	T & R
SOT23-6L	STG719STR

Power Consumption (<0.001mW typ.). ESD immunity is higher than 1000V per method 3015.7 of MIL-STD-883B. It's available in the commercial temperature range.

### PIN CONNECTION AND IEC LOGIC SYMBOLS

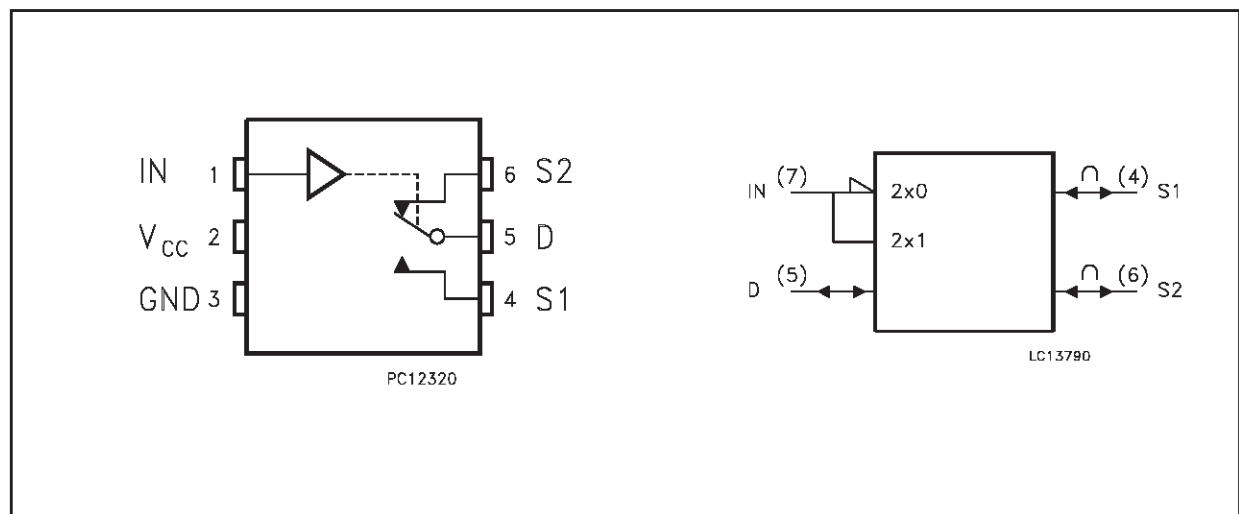

**INPUT EQUIVALENT CIRCUIT**

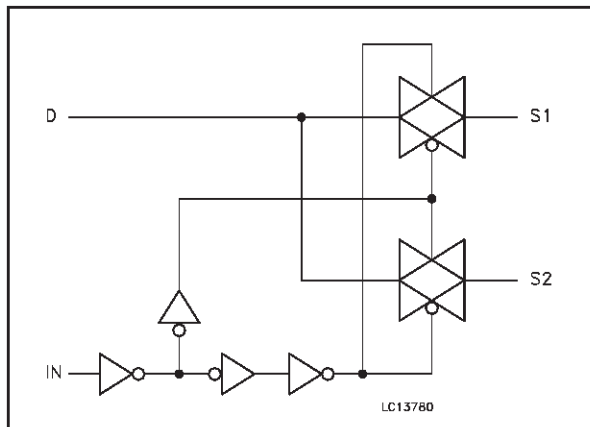

**PIN DESCRIPTION**

PIN No	SYMBOL	NAME AND FUNCTION
1	IN	Control
4, 6	S1, S2	Independent Channel
5	D	Common Channel
3	V <sub>CC</sub>	Positive Supply Voltage
2	GND	Ground (0V)

**TRUTH TABLE**

CONTROL	SWITCH S1	SWITCH S2
L	ON	OFF
H	OFF	ON

**ABSOLUTE MAXIMUM RATINGS**

Symbol	Parameter	Value	Unit
V <sub>CC</sub>	Supply Voltage	-0.5 to +7.0	V
V <sub>I</sub>	DC Input Voltage	-0.5 to V <sub>CC</sub> + 0.5	V
V <sub>IC</sub>	DC Control Input Voltage	-0.5 to V <sub>CC</sub> + 0.5	V
V <sub>O</sub>	DC Output Voltage	-0.5 to V <sub>CC</sub> + 0.5	V
I <sub>IK</sub>	DC Input Diode Current	± 20	mA
I <sub>OK</sub>	DC Output Diode Current	± 20	mA
I <sub>O</sub>	DC Output Current	± 50	mA
I <sub>CC</sub> or I <sub>GND</sub>	DC V <sub>CC</sub> or Ground Current	± 50	mA
T <sub>stg</sub>	Storage Temperature	-65 to +150	°C
T <sub>L</sub>	Lead Temperature (10 sec)	300	°C

Absolute Maximum Ratings are those values beyond which damage to the device may occur. Functional operation under these condition is not implied

**RECOMMENDED OPERATING CONDITIONS**

Symbol	Parameter	Value	Unit
V <sub>CC</sub>	Supply Voltage (note 1)	1.8 to 5.5	V
V <sub>I</sub>	Input Voltage	0 to V <sub>CC</sub>	V
V <sub>IC</sub>	Control Input Voltage	0 to V <sub>CC</sub>	V
V <sub>O</sub>	Output Voltage	0 to V <sub>CC</sub>	V
T <sub>op</sub>	Operating Temperature	-55 to 125	°C
dt/dv	Input Rise and Fall Time (note 2)	0 to 10	ns/V

1) Truth Table guaranteed: 1.2V to 6V  
 2) V<sub>IN</sub> from 30% to 70% of V<sub>CC</sub>

## DC SPECIFICATION

Symbol	Parameter	Test Condition		Value						Unit	
		V <sub>CC</sub> (V)		T <sub>A</sub> = 25°C			-40 to 85°C		-55 to 125°C		
				Min.	Typ.	Max.	Min.	Max.	Min.		Max.
V <sub>IHC</sub>	High Level Control Input Voltage	3.3(*)		2.0			2.0		2.0		V
		5.0(**)		2.4			2.4		2.4		
V <sub>ILC</sub>	Low Level Control Input Voltage	3.3(*)				0.4		0.4		0.4	V
		5.0(**)				0.8		0.8		0.8	
R <sub>ON</sub>	ON Resistance	3.3(*)	V <sub>S</sub> = 0 to V <sub>CC</sub> I <sub>S</sub> = 10mA		6	7		10			Ω
		5.0(**)				4		5			
ΔR <sub>ON</sub>	ON Resistance	3.3(*)	V <sub>S</sub> = 0 to V <sub>CC</sub> I <sub>S</sub> = 10mA		0.1			0.4			Ω
		5.0(**)			0.1		0.4				
R <sub>FLATON</sub>	ON Resistance fLATNESS	3.3(*)	V <sub>S</sub> = 0 to V <sub>CC</sub> I <sub>S</sub> = 10mA		2.5						Ω
		5.0(**)			0.75						
I <sub>SOFF</sub>	Source OFF Leakage	3.3(*)	V <sub>S</sub> = 1V or V <sub>CC</sub> V <sub>DD</sub> = V <sub>CC</sub> or 1V V <sub>IN</sub> = V <sub>CC</sub> or GND		±0.01	±0.25		± 0.35		± 0.35	μA
		5.0(**)			±0.01	±0.25		± 0.35		± 0.35	
I <sub>SON</sub>	Channel ON Leakage	3.3(*)	V <sub>S</sub> = V <sub>D</sub> = 1V to V <sub>CC</sub> - 2.5V V <sub>IN</sub> = V <sub>IHC</sub>		±0.01	±0.25		± 0.35		± 0.35	μA
		5.0(**)			±0.01	±0.25		± 0.35		± 0.35	
I <sub>IN</sub>	Control Input Leakage Current	3.3(*)	V <sub>I</sub> = V <sub>IH</sub> or V <sub>IL</sub>		0.005			±0.1			μA
		5.0(**)			0.005		±0.1				
I <sub>CC</sub>	Quiescent Supply Current	3.3(*)	V <sub>I</sub> = V <sub>CC</sub> or GND		0.001	1		1			μA
		5.0(**)			0.001		1				

(\*) Voltage range is 3.3V ± 0.3V

(\*\*) Voltage range is 5V ± 0.5V

AC ELECTRICAL CHARACTERISTICS (C<sub>L</sub> = 35pF, R<sub>L</sub> = 300Ω)

Symbol	Parameter	Test Condition		Value						Unit	
		V <sub>CC</sub> (V)		T <sub>A</sub> = 25°C			-40 to 85°C		-55 to 125°C		
				Min.	Typ.	Max.	Min.	Max.	Min.		Max.
t <sub>PD</sub>	Delay Time	3.3(*)	V <sub>S</sub> = 3V square wave f = 1MHz t <sub>r</sub> = t <sub>f</sub> = 6ns		0.4	0.8		1.2			ns
		5.0(**)			0.3	0.6		1.0			
t <sub>ON</sub>	ON Channel Time	3.3(*)	V <sub>S</sub> = 2V		10			16			ns
		5.0(**)	V <sub>S</sub> = 3V		7			11			
t <sub>OFF</sub>	OFF Channel Time	3.3(*)	V <sub>S</sub> = 2V		5.5			7			ns
		5.0(**)	V <sub>S</sub> = 3V		4.5			6			
t <sub>D</sub>	Break Before Make Time Delay	3.3(*)	V <sub>S</sub> = 2V	1	4						ns
		5.0(**)	V <sub>S</sub> = 3V	1	4						
C <sub>SOFF</sub>	OFF Channel Capacitance										pF
C <sub>SON</sub>	ON Channel Capacitance										pF

(\*) Voltage range is 3.3V ± 0.3V

(\*\*) Voltage range is 5.0V ± 0.5V



**ANALOG SWITCH CHARACTERISTICS (GND = 0V; T<sub>A</sub> = 25°C)**

Symbol	Parameter	Test Condition		Value	Unit
		V <sub>CC</sub> (V)		Typ.	
f <sub>MAX</sub>	Frequency Response (Switch ON)	3.3 <sup>(*)</sup>	Bandwidth at -3dB	200	MHz
		5.0 <sup>(**)</sup>		200	
	Feedthrough Attenuation (Switch OFF)	3.3 <sup>(*)</sup>	f <sub>IN</sub> = 10MHz sine wave	-40	dB
		3.3 <sup>(*)</sup>	f <sub>IN</sub> = 1MHz sine wave	-74	
		5.0 <sup>(**)</sup>	f <sub>IN</sub> = 10MHz sine wave	-40	
		5.0 <sup>(**)</sup>	f <sub>IN</sub> = 1MHz sine wave	-74	
	Crosstalk (Channel to Chabbel)	3.3 <sup>(*)</sup>	f <sub>IN</sub> = 10MHz sine wave	-39	dB
		3.3 <sup>(*)</sup>	f <sub>IN</sub> = 1MHz sine wave	-52	
		5.0 <sup>(**)</sup>	f <sub>IN</sub> = 10MHz sine wave	-39	
		5.0 <sup>(**)</sup>	f <sub>IN</sub> = 1MHz sine wave	-52	

(\*)Voltage range is 3.3V ± 0.3V  
 (\*\*) Voltage range is 5.0V ± 0.5V

**TEST CIRCUITS**

**ON RESISTANCE**

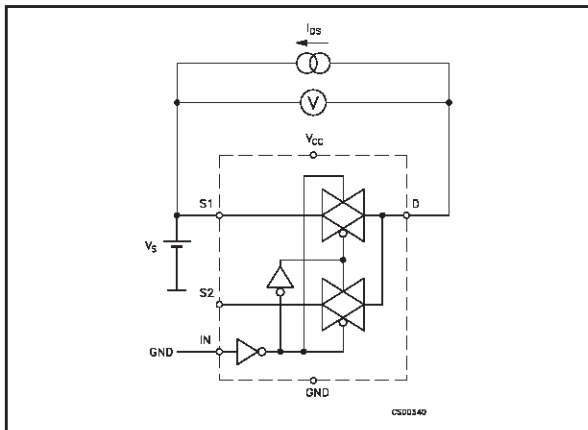

**OFF LEAKAGE**

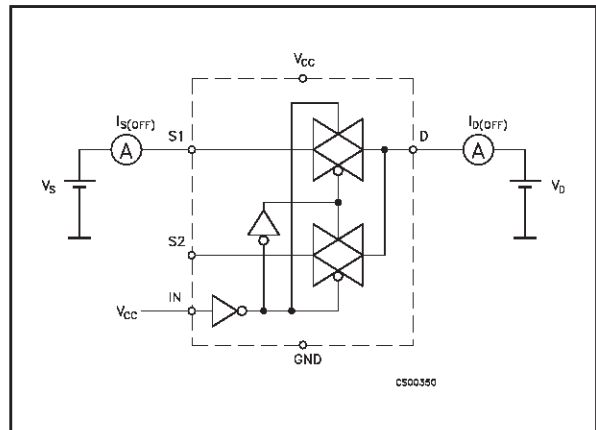

**ON LEAKAGE**

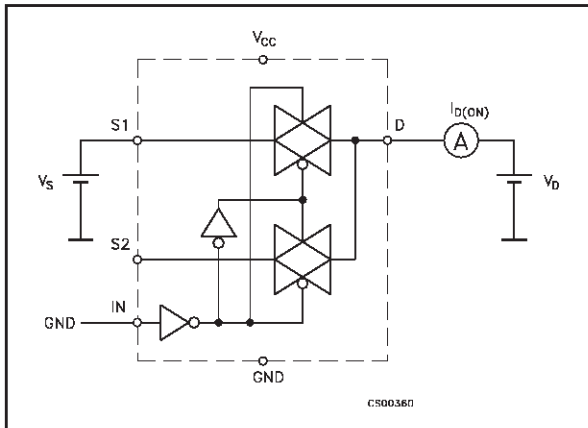

**OFF ISOLATION**

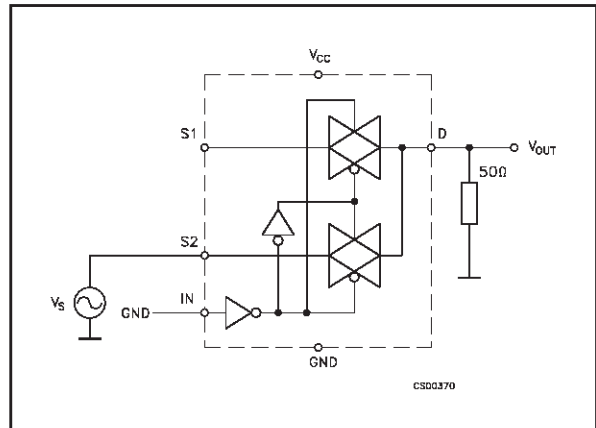

**BANDWIDTH**

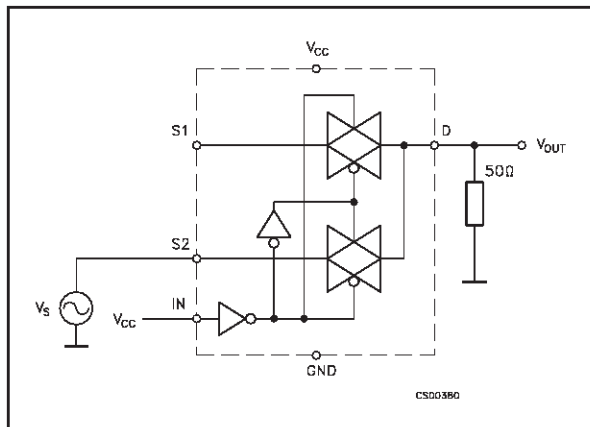

**CHANNEL TO CHANNEL CROSSTALK**

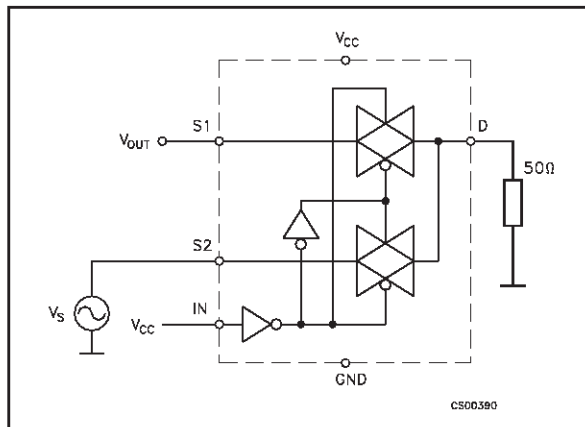

**SWITCHING TIMES**

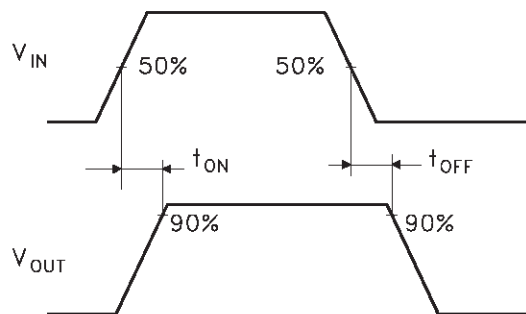
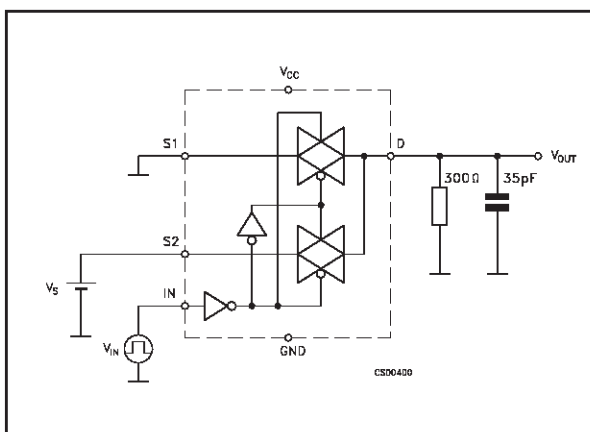

CS00420

**BREAK BEFORE MAKE TIME DLEAY**

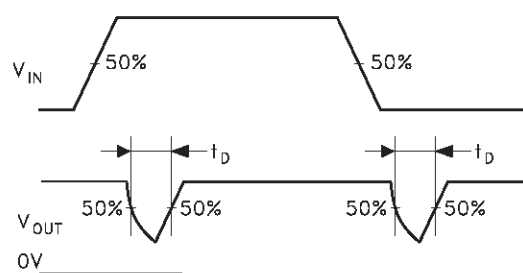
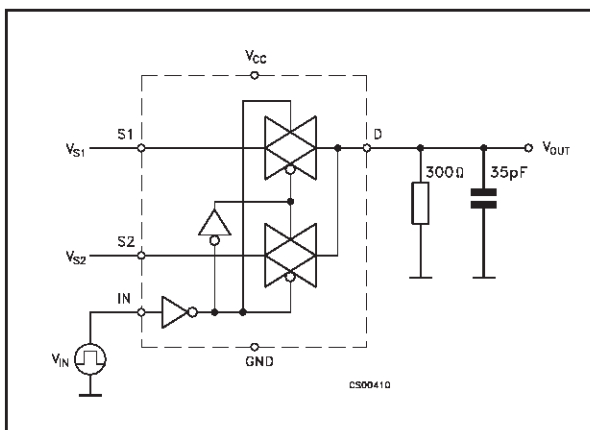

CS00430

## SOT23-6L MECHANICAL DATA

DIM.	mm.			mils		
	MIN.	TYP.	MAX.	MIN.	TYP.	MAX.
A	0.90		1.45	35.4		57.1
A1	0.00		0.15	0.0		5.9
A2	0.90		1.30	35.4		51.2
b	0.35		0.50	13.7		19.7
C	0.09		0.20	3.5		7.8
D	2.80		3.00	110.2		118.1
E	2.60		3.00	102.3		118.1
E1	1.50		1.75	59.0		68.8
e		0.95			37.4	
e1		1.9			74.8	
L	0.35		0.55	13.7		21.6

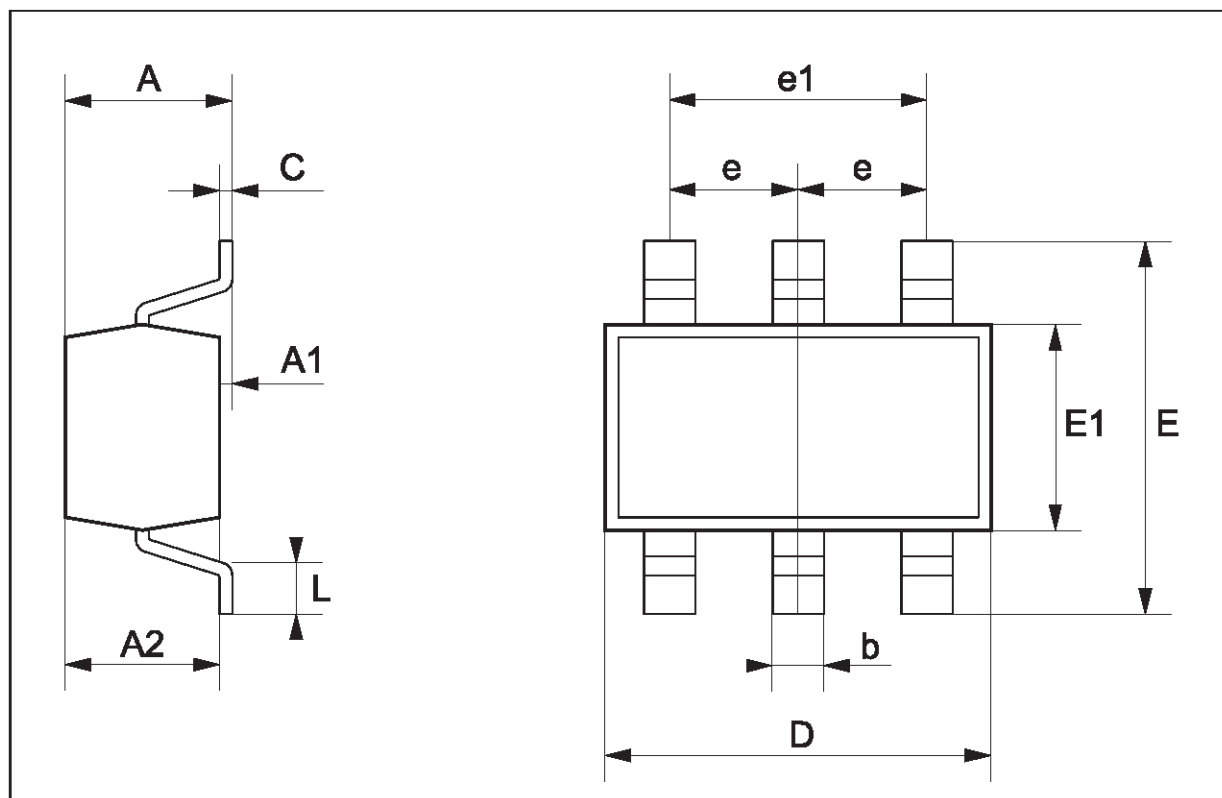

## Tape &amp; Reel SOT23-xL MECHANICAL DATA

DIM.	mm.			inch		
	MIN.	TYP	MAX.	MIN.	TYP.	MAX.
A			180			7.086
C	12.8	13.0	13.2	0.504	0.512	0.519
D	20.2			0.795		
N	60			2.362		
T			14.4			0.567
Ao	3.13	3.23	3.33	0.123	0.127	0.131
Bo	3.07	3.17	3.27	0.120	0.124	0.128
Ko	1.27	1.37	1.47	0.050	0.054	0.058
Po	3.9	4.0	4.1	0.153	0.157	0.161
P	3.9	4.0	4.1	0.153	0.157	0.161

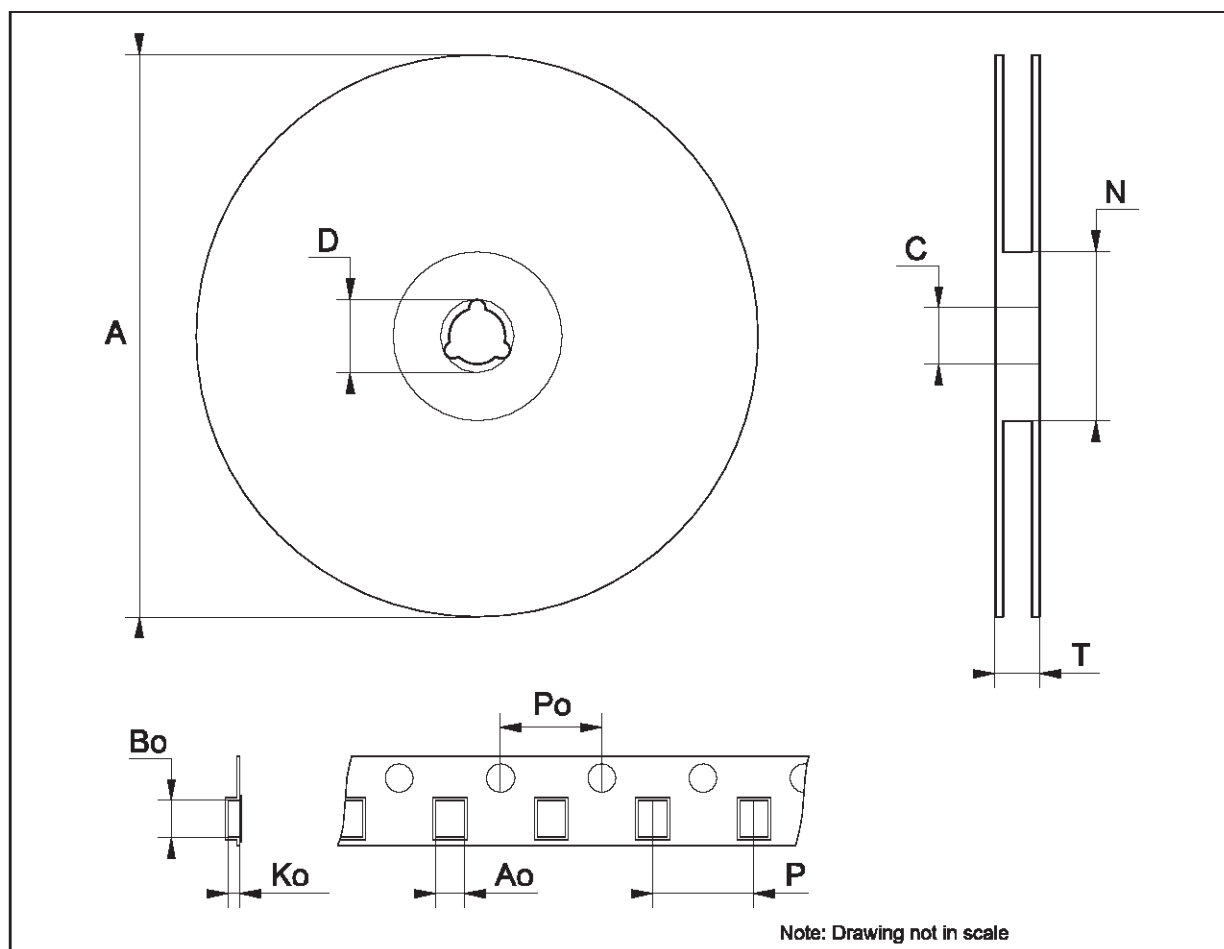

Information furnished is believed to be accurate and reliable. However, STMicroelectronics assumes no responsibility for the consequences of use of such information nor for any infringement of patents or other rights of third parties which may result from its use. No license is granted by implication or otherwise under any patent or patent rights of STMicroelectronics. Specifications mentioned in this publication are subject to change without notice. This publication supersedes and replaces all information previously supplied. STMicroelectronics products are not authorized for use as critical components in life support devices or systems without express written approval of STMicroelectronics.

© The ST logo is a registered trademark of STMicroelectronics

© 2002 STMicroelectronics - Printed in Italy - All Rights Reserved  
STMicroelectronics GROUP OF COMPANIES

Australia - Brazil - Canada - China - Finland - France - Germany - Hong Kong - India - Israel - Italy - Japan - Malaysia - Malta - Morocco  
Singapore - Spain - Sweden - Switzerland - United Kingdom - United States.

© <http://www.st.com>