



# STGB10NB37LZ

## N-CHANNEL CLAMPED 20A - D2PAK INTERNALLY CLAMPED PowerMesh™ IGBT

TYPE	V <sub>CES</sub>	V <sub>CE(sat)</sub>	I <sub>C</sub>
STGB10NB37LZ	CLAMPED	< 1.8 V	20 A

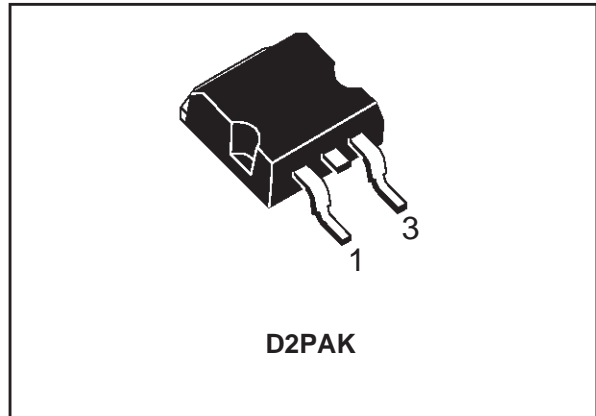
- POLYSILICON GATE VOLTAGE DRIVEN
- LOW THRESHOLD VOLTAGE
- LOW ON-VOLTAGE DROP
- LOW GATE CHARGE
- HIGH CURRENT CAPABILITY
- HIGH VOLTAGE CLAMPING FEATURE

### DESCRIPTION

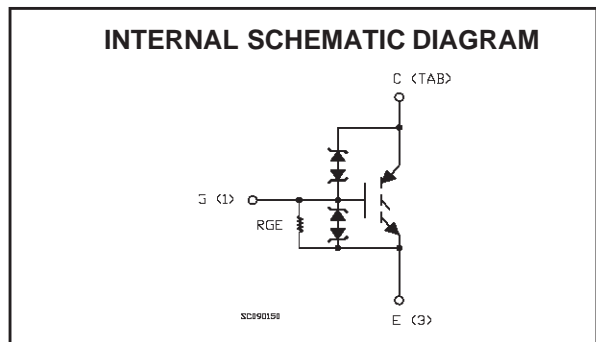
Using the latest high voltage technology based on a patented strip layout, STMicroelectronics has designed an advanced family of IGBTs, the PowerMESH™ IGBTs, with outstanding performances. The built in collector-gate zener exhibits a very precise active clamping while the gate-emitter zener supplies an ESD protection.

### APPLICATIONS

- AUTOMOTIVE IGNITION



D2PAK



### ABSOLUTE MAXIMUM RATINGS

Symbol	Parameter	Value	Unit
V <sub>CES</sub>	Collector-Emitter Voltage (V <sub>GS</sub> = 0)	CLAMPED	V
V <sub>ECR</sub>	Reverse Battery Protection	18	V
V <sub>GE</sub>	Gate-Emitter Voltage	CLAMPED	V
I <sub>C</sub>	Collector Current (continuous) at T <sub>C</sub> = 100°C	20	A
I <sub>CM</sub>	Collector Current (pulse width < 100μs)	60	A
P <sub>TOT</sub>	Total Dissipation at T <sub>C</sub> = 25°C	125	W
	Derating Factor	0.83	W/°C
ESD	ESD (Human Body Model)	4	KV
T <sub>stg</sub>	Storage Temperature	-65 to 175	°C
T <sub>j</sub>	Max. Operating Junction Temperature	175	°C

## STGB10NB37LZ

### THERMAL DATA

Rthj-case	Thermal Resistance Junction-case Max	1.2	°C/W
Rthj-amb	Thermal Resistance Junction-ambient Max	62.5	°C/W
Rthc-sink	Thermal Resistance Case-sink Typ	0.2	°C/W

### ELECTRICAL CHARACTERISTICS (TCASE = 25 °C UNLESS OTHERWISE SPECIFIED)

OFF

Symbol	Parameter	Test Conditions	Min.	Typ.	Max.	Unit
BV(CES)	Clamped Voltage	$I_C = 2 \text{ mA}$ , $V_{GE} = 0$ , $T_j = -40^\circ\text{C}$ to $150^\circ\text{C}$	375	400	425	V
BV(ECR)	Emitter Collector Break-down Voltage	$I_{EC} = 75 \text{ mA}$ , $V_{GE} = 0$ , $T_j = -40^\circ\text{C}$ to $150^\circ\text{C}$	18			V
BV <sub>GE</sub>	Gate Emitter Break-down Voltage	$I_G = \pm 2 \text{ mA}$ $T_j = -40^\circ\text{C}$ to $150^\circ\text{C}$	12		16	V
I <sub>CES</sub>	Collector cut-off Current ( $V_{GE} = 0$ )	$V_{CE} = 15 \text{ V}$ , $V_{GE} = 0$ , $T_j = 150^\circ\text{C}$ $V_{CE} = 200 \text{ V}$ , $V_{GE} = 0$ , $T_C = 150^\circ\text{C}$			10 100	$\mu\text{A}$ $\mu\text{A}$
I <sub>GES</sub>	Gate-Emitter Leakage Current ( $V_{CE} = 0$ )	$V_{GE} = \pm 10 \text{ V}$ , $V_{CE} = 0$			$\pm 700$	$\mu\text{A}$
R <sub>GE</sub>	Gate Emitter Resistance			20		K $\Omega$

ON (1)

Symbol	Parameter	Test Conditions	Min.	Typ.	Max.	Unit
V <sub>GE(th)</sub>	Gate Threshold Voltage	$V_{CE} = V_{GE}$ , $I_C = 250 \mu\text{A}$ , $T_j = -40^\circ\text{C}$ to $150^\circ\text{C}$	0.6		2.4	V
V <sub>CE(SAT)</sub>	Collector-Emitter Saturation Voltage	$V_{GE} = 4.5 \text{ V}$ , $I_C = 10 \text{ A}$ , $T_j = 25^\circ\text{C}$ $V_{GE} = 4.5 \text{ V}$ , $I_C = 10 \text{ A}$ , $T_C = -40^\circ\text{C}$		1.2 1.3	1.8	V V
I <sub>C</sub>	Collector Current	$V_{GE} = 4.5 \text{ V}$ , $V_{CE} = 9 \text{ V}$	20			A

DYNAMIC

Symbol	Parameter	Test Conditions	Min.	Typ.	Max.	Unit
g <sub>fs</sub>	Forward Transconductance	$V_{CE} = 15 \text{ V}$ , $I_C = 20 \text{ A}$		18		S
C <sub>ies</sub>	Input Capacitance	$V_{CE} = 25 \text{ V}$ , $f = 1 \text{ MHz}$ , $V_{GE} = 0$		1250		pF
C <sub>oes</sub>	Output Capacitance			103		pF
C <sub>res</sub>	Reverse Transfer Capacitance			18		pF
Q <sub>g</sub>	Gate Charge	$V_{CE} = 320 \text{ V}$ , $I_C = 10 \text{ A}$ , $V_{GE} = 5 \text{ V}$		28		nC

FUNCTIONAL CHARACTERISTICS

Symbol	Parameter	Test Conditions	Min.	Typ.	Max.	Unit
$I_L$	Latching Current	$V_{Clamp} = 320\text{ V}$ , $T_C = 125\text{ }^\circ\text{C}$ $R_{GOFF} = 1\text{K}\Omega$ , $V_{GE} = 5\text{ V}$ $L = 300\mu\text{H}$	20			A
U.I.S.	Unclamped Inductive Switching Current	$R_{GOFF} = 1\text{K}\Omega$ , $L = 1.6\text{ mH}$ , $T_C = 125\text{ }^\circ\text{C}$ , $V_{CC} = 30\text{ V}$	15			A

SWITCHING ON

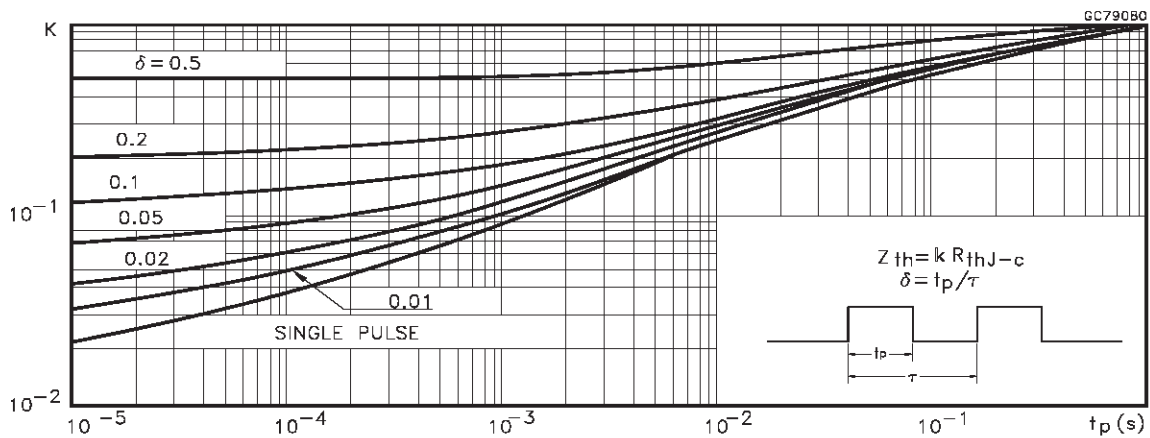
Symbol	Parameter	Test Conditions	Min.	Typ.	Max.	Unit
$t_{d(on)}$	Turn-on Delay Time	$V_{CC} = 320\text{ V}$ , $I_C = 10\text{ A}$		520		ns
$t_r$	Rise Time	$R_G = 1\text{K}\Omega$ , $V_{GE} = 5\text{ V}$		340		ns
$(di/dt)_{on}$	Turn-on Current Slope	$V_{CC} = 320\text{ V}$ , $I_C = 10\text{ A}$		17		A/ $\mu\text{s}$
$E_{on}$	Turn-on Switching Losses	$R_G = 1\text{K}\Omega$ , $V_{GE} = 5\text{ V}$		180		$\mu\text{J}$

SWITCHING OFF

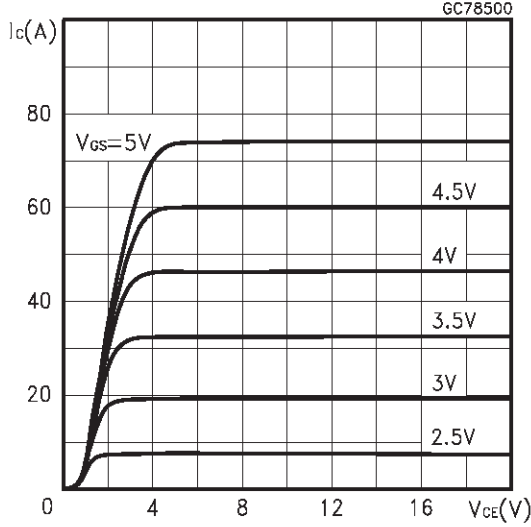
Symbol	Parameter	Test Conditions	Min.	Typ.	Max.	Unit
$t_c$	Cross-over Time	$V_{clamp} = 320\text{ V}$ , $I_C = 10\text{ A}$ , $R_{GE} = 1\text{K}\Omega$ , $V_{GE} = 5\text{ V}$		4		$\mu\text{s}$
$t_r(V_{off})$	Off Voltage Rise Time			2.2		$\mu\text{s}$
$t_{d(off)}$	Delay Time			14.8		$\mu\text{s}$
$t_f$	Fall Time			1.5		$\mu\text{s}$
$E_{off(**)}$	Turn-off Switching Loss			4.0		mJ
$t_c$	Cross-over Time	$V_{clamp} = 320\text{ V}$ , $I_C = 10\text{ A}$ , $R_{GE} = 1\text{K}\Omega$ , $V_{GE} = 5\text{ V}$ $T_j = 125\text{ }^\circ\text{C}$		5.2		$\mu\text{s}$
$t_r(V_{off})$	Off Voltage Rise Time			2.8		$\mu\text{s}$
$t_{d(off)}$	Delay Time			15.8		$\mu\text{s}$
$t_f$	Fall Time			2		$\mu\text{s}$
$E_{off(**)}$	Turn-off Switching Loss			6.5		mJ

(●) Pulsed: Pulse duration = 300  $\mu\text{s}$ , duty cycle 1.5 %. (1) Pulse width limited by max. junction temperature. (\*\*) Losses Include Also the Tail

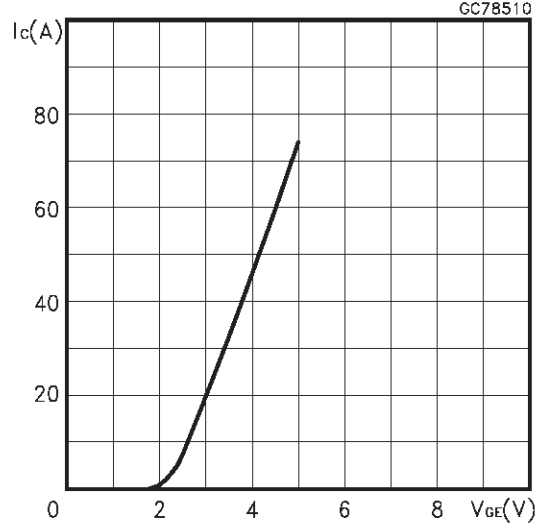
Normalized Transient Thermal Impedance



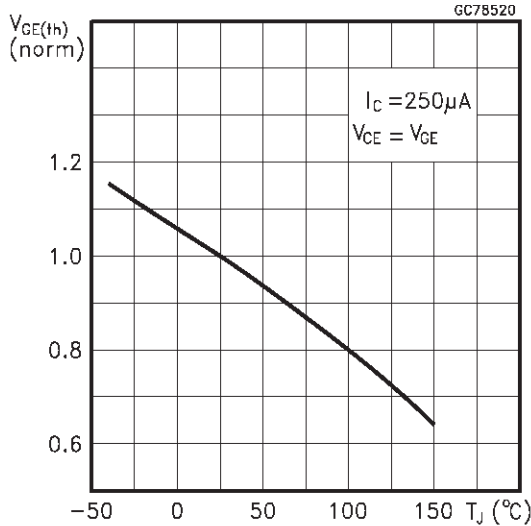
Output Characteristics



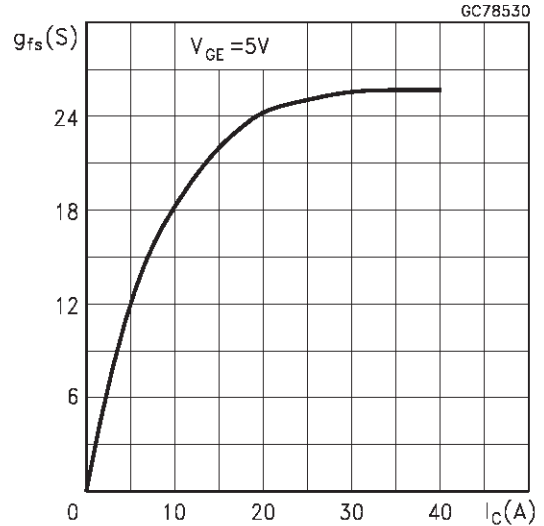
Transfer Characteristics



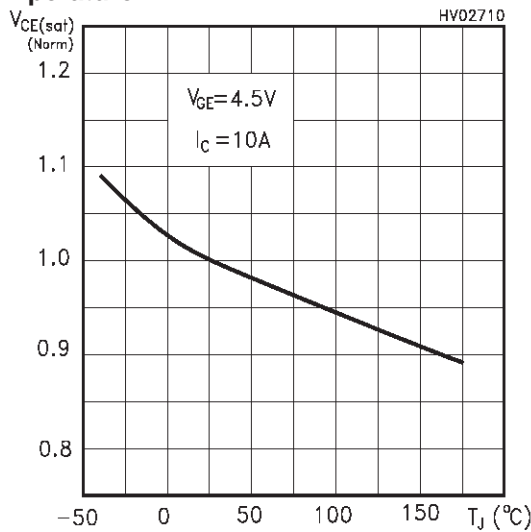
Normalized Gate Threshold Voltage vs Temp.



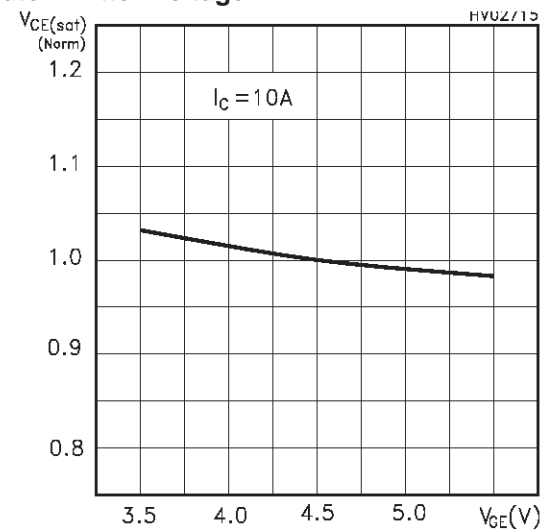
Transconductance



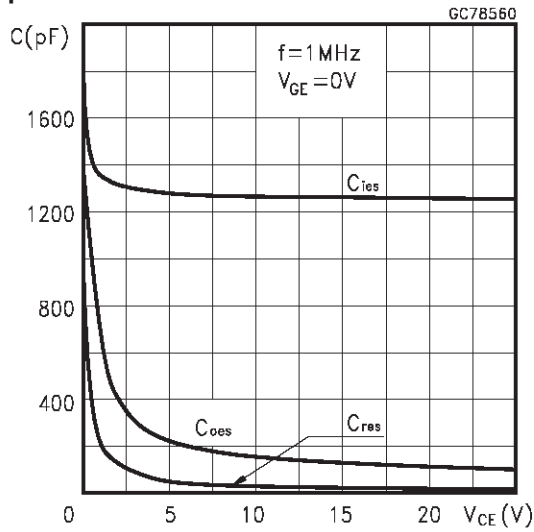
Normalized Collector-Emitter On Voltage vs Temperature



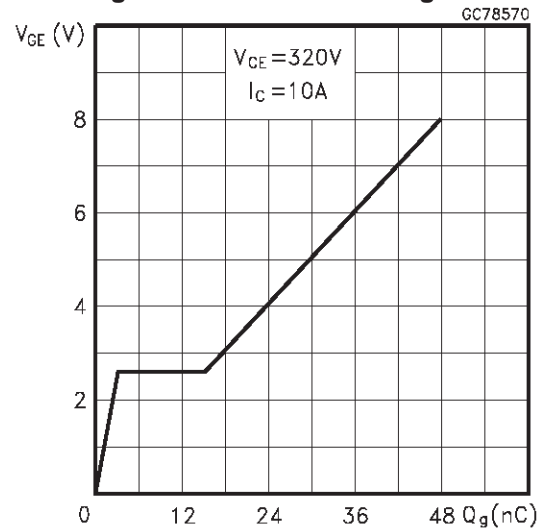
Normalized Collector-Emitter On Voltage vs Gate-Emitter Voltage



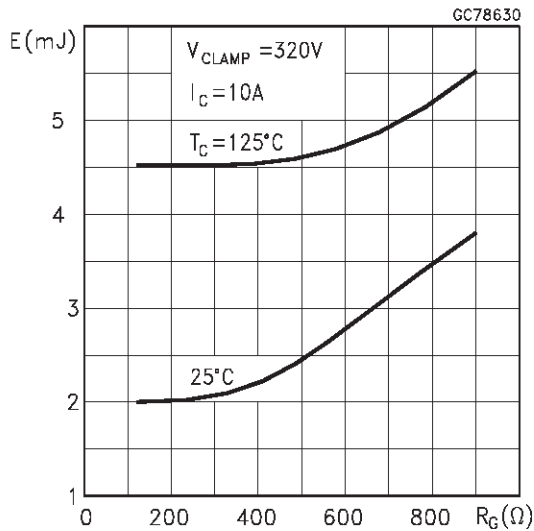
Capacitance Variations



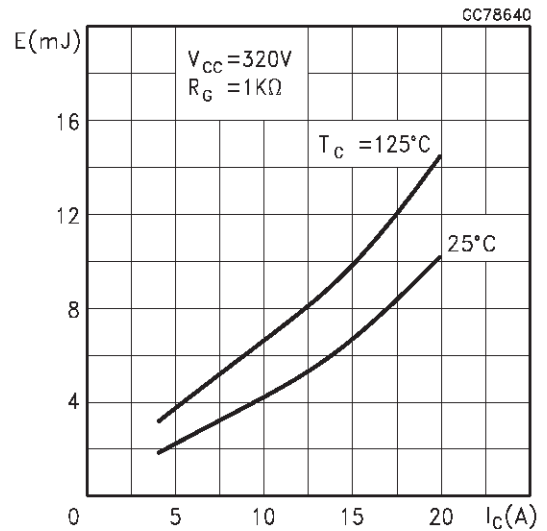
Gate Charge vs Gate-Emitter Voltage



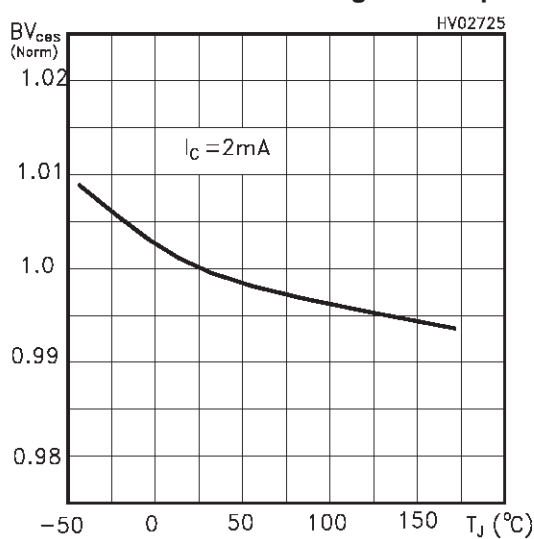
Off Losses vs Gate Resistance



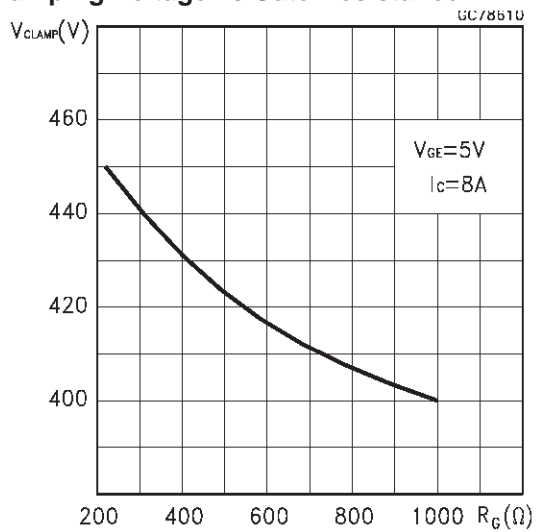
Off Losses vs Collector Current



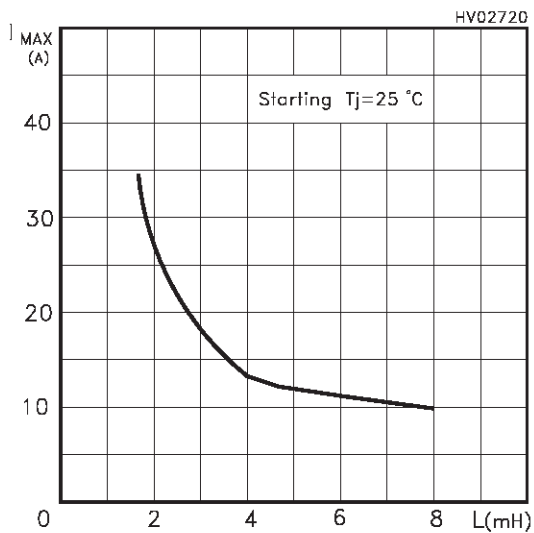
Normalized Break-down Voltage vs Temp.



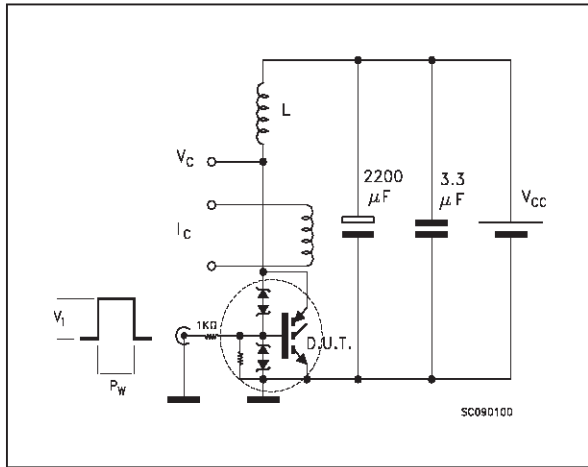
Clamping Voltage vs Gate Resistance



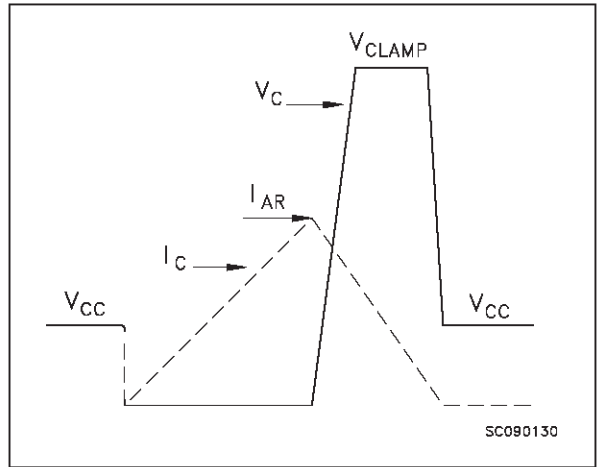
Self Clamped Inductive Switching I<sub>MAX</sub> vs Open Secondary Coil



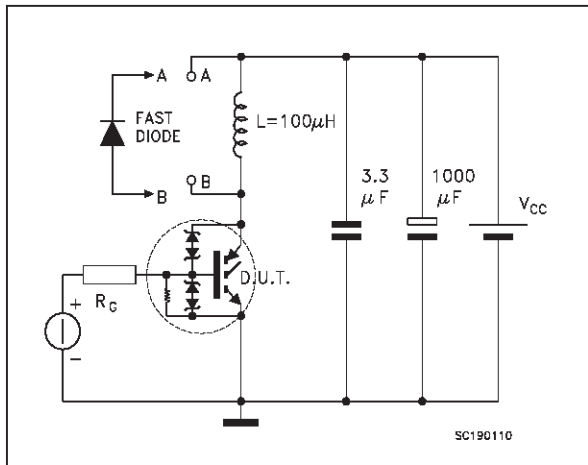
**Fig. 1: Unclamped Inductive Load Test Circuit**



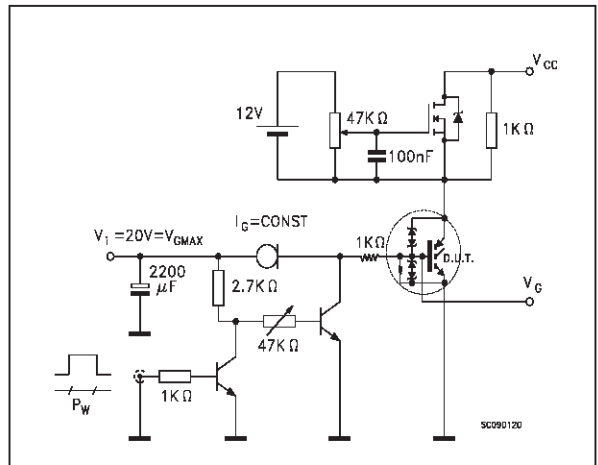
**Fig. 2: Unclamped Inductive Waveform**



**Fig. 3: Test Circuit For Inductive Load Switching And Diode Recovery Times**

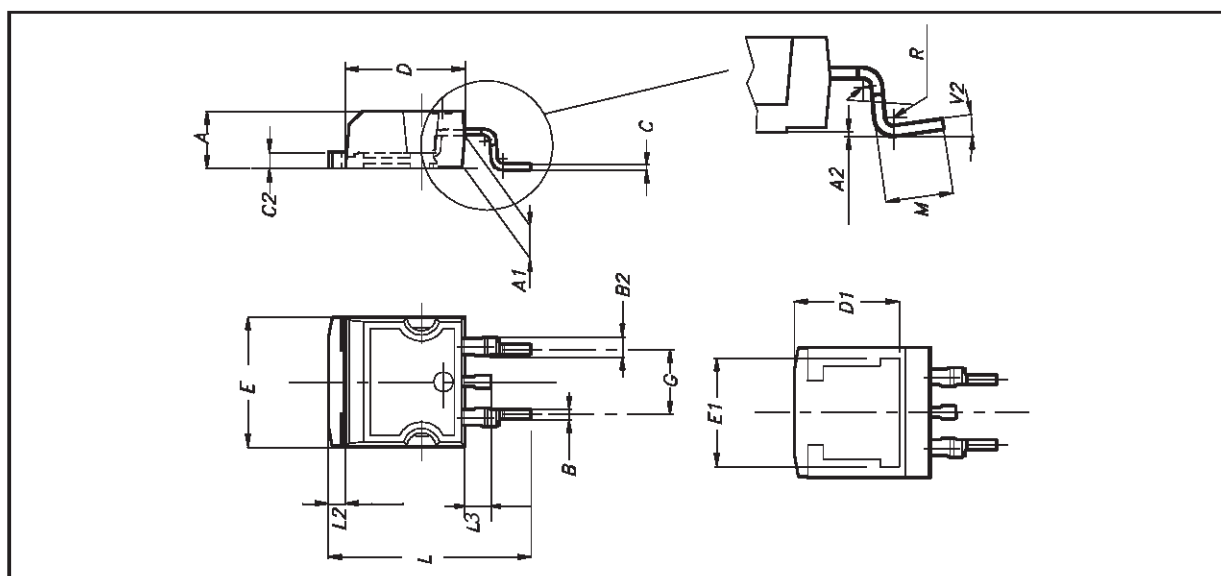


**Fig. 4: Gate Charge test Circuit**

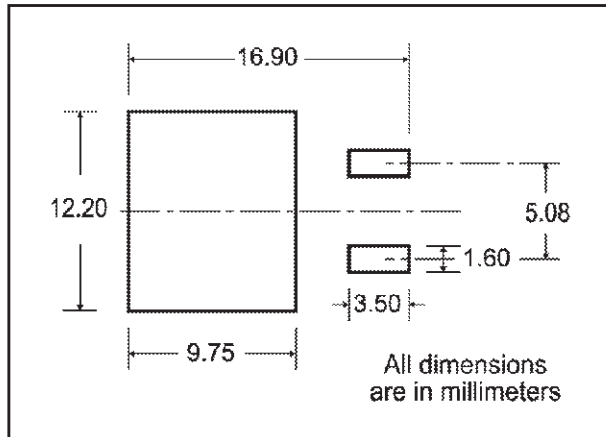


**D<sup>2</sup>PAK MECHANICAL DATA**

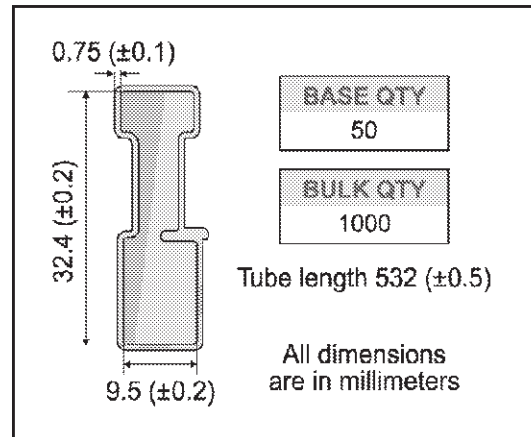
DIM.	mm.			inch		
	MIN.	TYP	MAX.	MIN.	TYP.	MAX.
A	4.4		4.6	0.173		0.181
A1	2.49		2.69	0.098		0.106
A2	0.03		0.23	0.001		0.009
B	0.7		0.93	0.027		0.036
B2	1.14		1.7	0.044		0.067
C	0.45		0.6	0.017		0.023
C2	1.23		1.36	0.048		0.053
D	8.95		9.35	0.352		0.368
D1		8			0.315	
E	10		10.4	0.393		
E1		8.5			0.334	
G	4.88		5.28	0.192		0.208
L	15		15.85	0.590		0.625
L2	1.27		1.4	0.050		0.055
L3	1.4		1.75	0.055		0.068
M	2.4		3.2	0.094		0.126
R		0.4			0.015	
V2	0°		8°			



**D<sup>2</sup>PAK FOOTPRINT**



**TUBE SHIPMENT (no suffix)\***



**TAPE AND REEL SHIPMENT (suffix "T4")\***

40 mm min. Access hole at slot location

Full radius

Tape slot in core for tape start 2.5mm min. width

TAPE MECHANICAL DATA

DIM.	mm		inch	
	MIN.	MAX.	MIN.	MAX.
A0	10.5	10.7	0.413	0.421
B0	15.7	15.9	0.618	0.626
D	1.5	1.6	0.059	0.063
D1	1.59	1.61	0.062	0.063
E	1.65	1.85	0.065	0.073
F	11.4	11.6	0.449	0.456
K0	4.8	5.0	0.189	0.197
P0	3.9	4.1	0.153	0.161
P1	11.9	12.1	0.468	0.476
P2	1.9	2.1	0.075	0.082
R	50		1.574	
T	0.25	0.35	0.0098	0.0137
W	23.7	24.3	0.933	0.956

REEL MECHANICAL DATA

DIM.	mm		inch	
	MIN.	MAX.	MIN.	MAX.
A		330		12.992
B	1.5		0.059	
C	12.8	13.2	0.504	0.520
D	20.2		0.795	
G	24.4	26.4	0.960	1.039
N	100		3.937	
T		30.4		1.197

BASE QTY	BULK QTY
1000	1000

G measured at hub

10 pitches cumulative tolerance on tape + / - 0.2 mm

Center line of cavity

User Direction of Feed

Bending radius

R min.

TRL

FEED DIRECTION

Information furnished is believed to be accurate and reliable. However, STMicroelectronics assumes no responsibility for the consequences of use of such information nor for any infringement of patents or other rights of third parties which may result from its use. No license is granted by implication or otherwise under any patent or patent rights of STMicroelectronics. Specification mentioned in this publication are subject to change without notice. This publication supersedes and replaces all information previously supplied. STMicroelectronics products are not authorized for use as critical components in life support devices or systems without express written approval of STMicroelectronics.

The ST logo is a trademark of STMicroelectronics

© 2000 STMicroelectronics – Printed in Italy – All Rights Reserved

STMicroelectronics GROUP OF COMPANIES

Australia - Brazil - China - Finland - France - Germany - Hong Kong - India - Italy - Japan - Malaysia - Malta - Morocco -  
Singapore - Spain - Sweden - Switzerland - United Kingdom - U.S.A.

<http://www.st.com>